



UW MEDICAL CENTER – NORTHWEST

2024 Major Institution Master Plan Update

Final Environmental Impact Statement

March 1, 2024

**PUBLIC NOTICE
UNIVERSITY OF WASHINGTON**

Project Name: UWMC-Northwest Major Institution Master Plan (MIMP) Final EIS
Proponent & Lead Agency: University of Washington

Description of Proposal: The UW Medical Center – Northwest Major Institution Master Plan update will allow for space on the campus to accommodate projected population growth and corresponding increase in healthcare demands. It would also allow for replacing aging campus facilities with more energy efficient, lower maintenance, and appropriate systems for today’s medical center functional requirements. The Master Plan will include design guidelines and development standards for new development on the campus. The planning process is intended to foresee, assess, and outline mitigation measures for potential direct, indirect and cumulative impacts of development.

Please visit <https://facilities.uw.edu/Northwest-MIMP> for the Final EIS.

Location of proposal: 1550 N 115th Street, Seattle WA 98133. The project site is generally bounded by N 120th Street on the north, Meridian Avenue N to the east, N 115th Street on the south, and the Bikur Cholim Cemetery and multifamily residences to the west.

Responsible Official: Julie Blakeslee, AICP
University Planner
Box 359571
Seattle, WA 98195-9571
NorthwestMIMP@uw.edu

FINAL

ENVIRONMENTAL IMPACT STATEMENT

for the

**UNIVERSITY of WASHINGTON MEDICAL CENTER -
NORTHWEST**

**MAJOR INSTITUTION
MASTER PLAN UPDATE**

The Final EIS (FEIS) for the *UWMC-Northwest 2024 Major Institution Master Plan Update* has been prepared in compliance with the State Environmental Policy Act (SEPA) of 1971 (Chapter 43.21C, Revised Code of Washington); the SEPA Rules, effective April 4, 1984, as amended (Chapter 197-11, Washington Administrative Code); and rules adopted by the University of Washington implementing SEPA (478-324 WAC). Preparation of this FEIS is the responsibility of the University's Campus Architecture & Planning department. The Campus Architecture & Planning department and the University's SEPA Advisory Committee have determined that this document has been prepared in a responsible manner using appropriate methodology and they have directed the areas of research and analysis that were undertaken in preparation of this FEIS. This document is not an authorization for an action, nor does it constitute a decision or a recommendation for an action; in its final form, it will accompany the *Proposed Action* and will be considered in making the final decisions on the proposal.

Date of DEIS Issuance..... September 5, 2023

Date of FEIS Issuance..... March 1, 2024

FACT SHEET

PROJECT TITLE UWMC–Northwest – 2024 Major Institution Master Plan Update

PROPONENT/APPLICANT UWMC - Northwest

LOCATION The UWMC-Northwest campus is located in North Seattle between Highway 99 (Aurora Avenue) and I-5. The campus boundary (also referred to as the Major Institution Overlay (MIO) boundary) encompasses an area of approximately 33 acres. The campus extends from N 115th Street on the south, N 120th Street on the north, approximately Meridian Avenue N on the east, and the Stendall Place residential development and Bikur Cholim Cemetery on the west.

PROPOSED ACTION The Proposed Action involves adoption and implementation of an updated Major Institution Master Plan (*2024 MIMP Update*) for the UWMC-Northwest campus. The proposed *2024 MIMP Update* is described in detail in the UWMC-Northwest’s *2024 MIMP Update*, which is a separate document from this Final EIS; the proposed *2024 MIMP Update* is also summarized in Chapter 2 of this Final EIS. Key elements of the *2024 MIMP Update* that are analyzed in this Final EIS include:

- Campus Boundary – No changes to the current campus boundary are proposed.
- Building Space – A net increase in building space on campus of approximately 862,000 sq. ft. is proposed; along with the existing approximately 738,000 sq. ft. of building space, the UWMC-Northwest campus would contain up to 1.6 million sq. ft. of space.
- Building Locations – Potential development sites for proposed buildings could be located anywhere on campus, subject to proposed

building height limit overlays and perimeter setback areas.

- **Building Uses** - The mix of uses proposed for the UWMC-Northwest campus are consistent with the current campus and the City of Seattle's definition of a medical center, as they will relate to and support teaching hospital and clinics, labs, administrative offices, staff services, transportation, open space, food services, childcare, and facilities supporting the utilities and plant maintenance functions.
- **Development Standards** – Modification of certain development standards as authorized by the MIMP process, including height limit overlays and perimeter setback areas. Differing scenarios for height limit overlays and perimeter buffer areas are analyzed in this EIS.

EIS ALTERNATIVES

For the purposes of environmental review, three alternatives are analyzed in this EIS, including:

- **Alternative 1** – *2024 MIMP Update* with simplified plan for height limit overlays and perimeter building setback areas.
- **Alternative 2** – *2024 MIMP Update* with additional restrictions on building height limit overlays and perimeter building setback areas.
- **Alternative 3** – Proposed *2024 MIMP Update* with elements recommended from public comments and input with additional height restrictions and wider perimeter building setback areas.
- **No Action Alternative** – No changes to the building height overlays and setbacks, or the physical improvements that are proposed under the *2024 MIMP Update*.

LEAD AGENCY

University of Washington

SEPA RESPONSIBLE OFFICIAL

Julie Blakeslee
University Environmental and Land Use Planner
University of Washington
Campus Architecture & Planning
Box 359571
Seattle, WA 98195-9571
E-mail: jblakesl@uw.edu

PURPOSE OF THIS EIS

The SEPA environmental review process is designed to be used along with other decision-making factors to provide a comprehensive review of the proposal (WAC 197-11-055). The purpose of SEPA is to ensure that environmental values are given appropriate deliberation, along with other considerations.

The approval of the *2024 Major Institution Master Plan Update* is classified under SEPA as a non-project (also referred to as programmatic) action. A non-project action is defined as an action that is broader than a single specific project, and involves decisions on policies, plans or programs. An EIS for a non-project proposal does not require site specific analysis; instead the EIS addresses conditions at a more general level (WAC 197-11-422). As SEPA Lead Agency, the University of Washington is responsible for ensuring SEPA compliance.

FINAL ACTION

The decision by the Board of Regents, after consideration of environmental impacts and mitigation, to approve the *2024 Major Institution Master Plan Update* and associated Final EIS.

PERMITS AND APPROVALS

Preliminary investigation indicates that the following permits and/or approvals could be required or requested for the Proposed Actions. Additional permits/approvals may be identified during the review process associated with specific development projects.

University of Washington

- ***Board of Regents***
 - Approval of the Final *2024 Major Institution Master Plan Update* and associated Final EIS

Agencies with Jurisdiction

- ***State of Washington***
 - Dept. of Labor and Industries
 - Dept. of Ecology, Construction Stormwater General Permit
- ***Puget Sound Clean Air Agency***
 - Demolition and Asbestos Notification
- ***City of Seattle***
 - City Council approval of the *2024 Major institution Master Plan Update*
 - Master Use Permit
 - Grading Permit
 - Shoring Permit
 - Building Permits
 - Electrical Permits
 - Mechanical Permits
 - Occupancy Permits
 - Comprehensive Drainage Control Plain, Inspection and Maintenance Schedule
 - Construction Stormwater Control Plan Approvals
- ***Seattle Department of Transportation***
 - Street Use Permits (i.e., construction staging, construction operations, etc.)
 - Street Improvements (i.e., traffic signal)
- ***Seattle-King County Department of Health***
 - Plumbing Permits

DRAFT EIS AUTHORS AND PRINCIPAL CONTRIBUTORS

The *2024 Major Institution Master Plan Update* Final EIS has been prepared under the direction of the UWMC-Northwest and analyses were provided by the following consulting firms:

EIS Project Manager, Primary Author, Land Use/Relationship to Plans and Policies, Air Quality/GHG, Environmental Health, Aesthetics/Light & Glare/Shadows, Utilities and Construction.

EA Engineering, Science and Technology, Inc., PBC.
2200 Sixth Avenue, Suite 707
Seattle, WA 98121

Visual Simulations/Shadow Diagrams

NBBJ
223 Yale Street
Seattle, WA 98109

Historic Resources

Northwest Vernacular
Bremerton, WA 98337

Transportation

The Transpo Group
12131 113th Ave NE, Suite 203
Kirkland, WA 98034

LOCATION OF BACKGROUND INFORMATION

Background material and supporting documents are available by contacting the Responsible Official: Julie Blakeslee (jblakesl@uw.edu).

DATE OF FINAL EIS ISSUANCE

March 1, 2024

AVAILABILITY OF THE FINAL EIS

This Final EIS has been distributed to agencies, organizations and individuals noted on the Distribution List contained in **Appendix A** to this document. Copies of the Final EIS are also available for review on the University's SEPA webpage (<https://facilities.uw.edu/committees/sepa>), and at Seattle Public Library's Broadview Branch (12755 Greenwood Avenue N, Seattle, WA 98133) and Northgate Branch (10548 5th Avenue NE, Seattle, WA 98125).

TABLE OF CONTENTS

	<u>Page</u>
FACT SHEET	i
 Chapter 1 – SUMMARY	
1.1 Introduction	1-1
1.2 Project Summary.....	1-1
1.3 Major Institution Master Plan Goals.....	1-2
1.4 Proposed Action.....	1-2
1.5 EIS Alternatives	1-4
1.6 Impacts, Mitigation Measures and Significant Unavoidable Adverse Impacts.....	1-7
 Chapter 2 – INTRODUCTION AND DESCRIPTION OF THE PROPOSED ACTION AND ALTERNATIVES	
2.1 Proponent/Project Location	2-1
2.2 Overview/Proposed Action Summary	2-4
2.3 Current Campus/Surrounding Area Conditions.....	2-7
2.4 Major Institution Master Plan Process	2-10
2.5 Environmental Review and Purpose.....	2-11
2.6 Major Institution Master Plan Goals (Objectives)	2-12
2.7 Proposed Action(s).....	2-13
2.8 EIS Alternatives	2-18
2.9 Benefits and Disadvantages of Deferring Implementation of the Proposal.....	2-28
 Chapter 3 – UPDATES SUBSEQUENT TO ISSUANCE OF THE DRAFT EIS	
3.1 Land Use/Relationship to Plans and Policies	3-2
3.2 Air Quality/GHG Emissions	3-4
3.3 Environmental Health	3-5
3.4 Aesthetics/Light & Glare/Shadows.....	3-7
3.5 Historic & Cultural Resources	3-11
3.6 Transportation	3-11
3.7 Utilities	3-14
3.8 Construction Impacts.....	3-15
 Chapter 4 – COMMENTS RECEIVED ON THE DRAFT EIS AND RESPONSES	

Chapter 5 – REFERENCES

APPENDICES

- A. Distribution List
- B. Transportation Discipline Report

LIST OF TABLES

<u>Table</u>	<u>Page</u>
1-1 Impact Summary Matrix	1-8
2-1 1991 Master Plan and Current Campus Development.....	2-5
2-2 Existing Campus Building Characteristics	2-9
2-3 Existing Campus Characteristics	2-10
2-4 Potential Building Demolition.....	2-16
2-5 Comparison of EIS Alternatives.....	2-27

LIST OF FIGURES

<u>Figure</u>	<u>Page</u>
2-1 Regional Map	2-2
2-2 Vicinity Map	2-3
2-3 Existing Campus Buildings.....	2-8
2-4 Potential Building Demolition.....	2-14
2-5 Alternative 1 Height Limit Overlays and Perimeter Setbacks.....	2-20
2-6 Alternative 2 Height Limit Overlays and Perimeter Setbacks.....	2-23
2-7 Alternative 3 Height Limit Overlays and Perimeter Setbacks.....	2-25
3-1 Alternative 3 Visual Simulation from Viewpoint 4	3-9
3-2 Alternative 3 Visual Simulation from Viewpoint 5	3-10

CHAPTER 1

SUMMARY

1.1 INTRODUCTION

This chapter provides a summary of the analysis presented in the Draft Environmental Impact Statement (Draft EIS) and in this Final EIS for the proposed *UWMC-Northwest 2024 Major Institution Master Plan Update (2024 MIMP Update)*. Information added or changed subsequent to issuance of the Draft EIS is shaded to ease identification of the added or changed information.

Chapter 1 of this Final EIS briefly describes the Proposed Action and the EIS Alternatives (Alternative 1, Alternative 2, Alternative 3 and the No Action Alternative), and contains a comprehensive overview of environmental impacts identified for the alternatives. Please see **Chapter 2** of this Final EIS for a more detailed description of the Proposed Action and alternatives and **Chapter 3** for a description of updates made subsequent to issuance of the Draft EIS, including Alternative 3.

1.2 PROJECT SUMMARY

The UWMC-Northwest campus is located in North Seattle between Highway 99 (Aurora Avenue) and I-5. The campus boundary (also referred to as the Major Institution Overlay (MIO) boundary) encompasses an area of approximately 33 acres. The campus extends from N 115th Street on the south, N 120th Street on the north, approximately Meridian Avenue N on the east, and the Stendall Place residential development and Bikur Cholim Cemetery on the west.

The UWMC-Northwest campus is within the City of Seattle MIO. The MIO is intended, among other things, to permit appropriate institutional growth within boundaries while minimizing the adverse impacts associated with development, balance a major institution's ability to change with need, to protect adjacent neighborhoods, encourage the concentration of institutions on existing campuses, and provide for coordinated growth through MIMPs (SMC 23.69). The first MIMP for UWMC-Northwest was adopted by the Seattle City Council in November 1991. The 1991 Final Adopted Master Plan included provisions for: Campus Boundary; Building Development; Building Heights; Setbacks; Access; and Landscaping.

Because the building capacity established under the 1991 MIMP is essentially utilized (approximately 26,000 sq. ft. of capacity remaining), the UWMC-Northwest is proposing an

updated MIMP to guide future development on the campus to help address health care needs of the region. The proposed *2024 MIMP Update* represents an update to the original MIMP prepared by UWMC-Northwest in compliance with Seattle Municipal Code (SMC) Chapter 23.69 for Major Institution Overlay Districts, as well as to fulfill the need for a comprehensive campus development plan.

To help meet the health care needs of the region, the proposed *2024 MIMP Update* includes growth in overall building space from the existing approximately 738,600 sq. ft. of building space to up to 1.6 million sq. ft. of building space (reflecting a net increase of approximately 862,000 sq. ft.) over approximately 20 years.

1.3 MAJOR INSTITUTION MASTER PLAN GOALS (OBJECTIVES)

The proposed *2024 MIMP Update* provides a long-term phased development plan that is intended to achieve the following development goals:

- **Accommodate Future Growth.** Accommodate future clinical care growth requirements while maintaining a positive campus experience for patients, visitors, staff, and the community.
- **Align Vision with Strategic Plan.** Align the UWMC - Northwest campus vision with the larger UW Medicine Strategic Plan.
- **Phase Growth for Future Needs.** Replace aging facilities, phase necessary campus expansion, and consider the energy efficiency and utility needs for future development.
- **Create Flexibility to Adapt with Changing Needs.** Create flexibility to support the dynamic, ever-changing healthcare market that allows project sequencing based on need and funding strategies.
- **Provide Community Engagement.** Through clear and transparent communication, ensure the community understands the project vision and can participate in the SEPA process.

1.4 PROPOSED ACTION

The development contemplated under the proposed *2024 MIMP Update* includes inpatient (hospital) and outpatient clinic buildings to replace and grow existing health care capacity. New support uses such as administrative offices, daycare (for staff families), central utility

plant(s), and parking structures are also planned. The Proposed Action involves adoption and implementation of the proposed *2024 MIMP Update*.

Proposed 2024 MIMP Update Features

Campus Boundary

The current campus boundary and size (approximately 33 acres) would not change under the proposed *2024 MIMP Update*.

Proposed Building Space

The proposed *2024 MIMP Update* includes growth in overall building space from the existing approximately 738,600 sq. ft. of building space to up to 1.6 million sq. ft. of building space (reflecting a net increase of approximately 862,000 sq. ft.) over approximately 20 years. Potential development sites for the proposed building projects could be located anywhere on the campus, subject to proposed building height limits, perimeter setback areas, and retained buildings (see **Figure 2-4** for an illustration of buildings to be retained and potential buildings to be removed).

Proposed Building Uses

The mix of uses proposed for the UWMC-Northwest campus are consistent with the current campus and the City of Seattle’s definition of a medical center, as they will relate to and support teaching hospital, labs, medical offices, staff services, transportation, open space, food services, childcare, and facilities supporting the utilities and plant maintenance functions. Example uses could include the following types of infrastructure and growth and/or replacement of medical center functions: hospital, support, and infrastructure.

Proposed Building Demolition

The proposed *2024 MIMP Update* anticipates several buildings would remain in their current configuration, with on-going maintenance. Potential development sites for building projects could be located anywhere on the campus, subject to proposed perimeter building setbacks. One or more of the existing buildings may be demolished, including B/C/E-Wings, Medical Arts Building, Childcare Building, and/or the Medical Office Building. Once functions can be relocated (on or off-campus), demolition of these buildings could remove up to 301,000 GSF from the campus.

Parking and Access

Planned construction of new patient care buildings would increase the number of parking stalls required on campus. On the UWMC-Northwest campus, new construction would also

remove existing stalls given that the majority of the available land to build is currently in use as surface parking lots. Additional parking may be built as an expansion of the existing parking structure and/or a standalone parking structure(s). A standalone facility may include support uses (clinics, administrative offices or childcare, for example) in front, or as part of, the parking structure. New parking garages would expand electric vehicle charging stations at UWMC-Northwest. [Note: parking structures and basement levels are excluded from area calculations and MIMP limits]. To support the 1.6 million gross sq. ft. of healthcare and support functions at UWMC-Northwest, total parking supply is anticipated to grow from 1,633 stalls to approximately 3,300 stalls in a combination of surface lots and structured parking.

The majority of the UWMC-Northwest campus access would continue from driveways from N 115th Street. It is assumed that the existing driveways on N 115th Street would be reconfigured to enhance the entry/exit movement for all modes of travel, including the eventual removal of the existing toll booths (east entry off N 115th Street) and existing gate arm (west entry off N 115th Street). A new third access point is analyzed for two optional locations: on N 115th Street immediately west of the McMurray Office Building, near the existing parking garage or on N 120th Street approximately opposite Densmore Avenue N. The third access drive is proposed from N 115th Street only (Alternative 3).

Central Utility Plant

The proposed 2024 MIMP Update includes a Central Utility Plant (CUP) intended to consolidate and separate the critical infrastructure that supports the Medical Center into a standalone enclosed facility. Because the proposed CUP would be enclosed and would utilize the latest best management technology, it is anticipated that the levels of operational noise and air emissions would be controlled in a more efficient manner than under current conditions. The proposed CUP is anticipated to include the following equipment: emergency generators, heat pumps, electrical switchgear, cooling towers, chillers, boilers, medical air and vacuum tanks, and an oxygen tank.

1.5 EIS ALTERNATIVES

For the purposes of environmental review, three action alternatives and a no action alternative are analyzed in this EIS, including: Alternative 1; Alternative 2; Alternative 3; and a No Action Alternative. A full description of these alternatives is provided in Chapter 2.

Alternative 1

Consistent with the Draft 2024 MIMP Update, Alternative 1 would include up to approximately 862,000 sq. ft. of net new building space that would be developed on the campus; resulting in a total of approximately 1.6 million sq. ft. of building space on campus

under Alternative 1. Under Alternative 1, and consistent with the Draft *2024 MIMP Update*, the UWMC-Northwest campus would house up to 515 hospital beds (an increase from the current 353 licensed hospital beds on campus). Alternative 1 also assumes the demolition of up to approximately 301,000 sq. ft. of building space. The buildings identified for demolition reflect buildings that are considered unlikely to be efficiently renovated and/or are anticipated to require removal to accommodate new and larger health care facilities.

Alternative 1 reflects a simplified plan for building height limit overlays and perimeter building setback areas intended to maintain development flexibility while preserving existing tree buffers along campus edges. Two height limit overlays are assumed under Alternative 1, including 65-feet where abutting parcels developed as residential uses; and, *175-feet* for the remainder of the campus. Proposed perimeter building setback areas are intended to allow for the preservation of the majority of the existing tree canopy and allow UWMC-Northwest to consider different phasing options that respond to community needs and replacement over time. Setback areas include a 30-foot setback where campus abuts rights of way (N 115th Street, N 120th Street, and Burke Avenue N) and a 40-foot setback where campus abuts adjacent properties.

Alternative 2

Similar to Alternative 1 and consistent with the Draft *2024 MIMP Update*, up to approximately 862,000 sq. ft. of net new building space would be developed on the campus; resulting in a total of approximately 1.6 million sq. ft. of building space on campus under Alternative 2. Under Alternative 2, the UWMC-Northwest campus would house up to 515 licensed hospital beds; an increase from the current 353 licensed hospital beds on campus. Alternative 2 also assumes the demolition of approximately 301,000 sq. ft. of building space.

Alternative 2 reflects additional restrictions on building height overlays compared to Alternative 1, including limiting the tallest building height to the central and southwest portions of the campus and adding a mid-range building height limit overlay (105 feet). The three building height limit overlays assumed under Alternative 2 include 65-feet at the north/northwest and eastern edges of campus abutting residential parcels; 105-feet in the southwest corner of campus (reflecting existing height limit); and, 175-feet for the remainder of the campus. Perimeter building setback areas under Alternative 2 would be narrower than under Alternative 1 and would include a 20-foot setback where campus abuts rights of way (N 115th Street, N 120th Street, and Burke Avenue N) and a 30-foot setback where campus abuts adjacent properties.

Alternative 3 - Preferred Alternative

Based on analysis conducted for the Draft EIS, and on comments received from the public and agencies on the Draft *2024 MIMP Update* and Draft EIS, an additional EIS Alternative (Alternative 3) has been identified for this Final EIS.

Similar to Alternatives 1 and 2, and consistent with the proposed *2024 MIMP Update*, up to approximately 862,000 sq. ft. of net new building space would be developed on the campus; resulting in a total of approximately 1.6 million sq. ft. of building space on campus under Alternative 3. Under Alternative 3, the UWMC-Northwest campus would house up to 515 licensed hospital beds; an increase from the current 353 licensed hospital beds on campus. Alternative 3 also assumes the demolition of approximately 301,000 sq. ft. of building space.

Compared to Alternatives 1 and 2, Alternative 3 provides updated building height overlays (a reduction in height in the north portion of the campus) and wider perimeter building setback areas (an increase to 40-foot building setback where the campus abuts residential properties to the east and west, and where the campus abuts the N 120th Street right-of-way to the north). See **Chapter 2** (Description of the Proposed Actions and Alternatives) of this Final EIS for detail.

Parking and internal campus circulation, including a campus loop road, would be generally as described for Alternatives 1 and 2¹. Alternative 3 identifies the third access drive as being from N 115th Street only and does not assume the option of a third access from N 120th Street assumed under Alternatives 1 and 2.

No Action Alternative

The No Action Alternative is intended to reflect conditions on the UWMC-Northwest campus if no *2024 MIMP Update* were to be approved, and improvements to address increased health care needs were not implemented. It is anticipated that the approximately 26,000 sq. ft. of remaining campus building capacity under the 1991 Master Plan would be developed, which would accommodate approximately 3% of anticipated demand for health care supporting building space over the next approximately 20 years. The No Action Alternative does not meet the objectives of UWMC-Northwest.

¹ Subsequent to issuance for the Draft EIS, the proposed parking supply in the *2024 MIMP Update* was adjusted from approximately 3,533 to approximately 3,300, and this updated parking supply is assumed for Alternative 3.

1.6 IMPACTS, MITIGATION MEASURES AND
SIGNIFICANT UNAVOIDABLE ADVERSE IMPACTS

The following highlights the impacts, mitigation measures, and significant unavoidable adverse impacts that would potentially result from the alternatives analyzed in this Draft EIS. **Table 1-1** provides a summary of the potential impacts that would be anticipated under the Draft EIS Alternatives. This summary is not intended to be a substitute for the complete discussion of each element that is contained in **Chapter 3 of the Draft EIS**.

Information added or changed in **Table 1-1** subsequent to issuance of the Draft EIS is shaded to ease identification of the added or changed information.

**Table 1-1
IMPACT SUMMARY MATRIX**

Alternative 1	Alternative 2	Alternative 3 – Preferred Alternative	No Action Alternative
3.1 – Land Use			
<ul style="list-style-type: none"> Development of up to 862,000 sq. ft. of net new building space), demolition of up to 301,000 sq. ft. of existing building space, dedicated perimeter building setback areas, and increased building heights. 	<ul style="list-style-type: none"> Same amount of building development, building demolition, with additional restrictions on building heights, with less area in perimeter building setback areas. 	<ul style="list-style-type: none"> Same amount of building development and building demolition, with more restrictions on building height (in north portion of campus) and more area in perimeter building setback area. 	<ul style="list-style-type: none"> Development of the remaining approximately 26,000 sq.ft. of development capacity under the existing 1991 MIMP. Existing building heights and perimeter building setbacks.
<ul style="list-style-type: none"> Development would result in an intensification of existing land use character. 	<ul style="list-style-type: none"> Same as Alternative 1. 	<ul style="list-style-type: none"> Same as Alternatives 1 and 2. 	<ul style="list-style-type: none"> Level of development and intensification substantially less than under Alternatives 1, 2 and 3.
<ul style="list-style-type: none"> Development would not represent a change in the Medical Center land use character of the campus. 	<ul style="list-style-type: none"> Same as Alternative 1. 	<ul style="list-style-type: none"> Same as Alternatives 1 and 2. 	<ul style="list-style-type: none"> Same as Alternatives 1, 2 and 3.
3.2 – Air Quality			
<ul style="list-style-type: none"> Campus development would increase the consumption of 	<ul style="list-style-type: none"> Same as Alternative 1. 	<ul style="list-style-type: none"> Same as Alternatives 1 and 2. 	<ul style="list-style-type: none"> The level of consumption of electricity, fossil fuels and

Alternative 1	Alternative 2	Alternative 3 – Preferred Alternative	No Action Alternative
<p>electricity, fossil fuel, and natural gas on the campus which could contribute to cumulative air quality impacts. However, it is anticipated that new buildings under the Draft <i>2024 MIMP Update</i> would be designed to be more energy efficient than existing buildings of similar size on campus. Any emissions would be subject to applicable requirements of the University of Washington and the Puget Sound Clean Air Agency.</p>			<p>natural gas, and associated emissions would be less than Alternatives 1, 2 and 3.</p>
<ul style="list-style-type: none"> Development under Alternative 1 would generate increased CO₂ over the lifespan of building development. 	<ul style="list-style-type: none"> Same as Alternative 1. 	<ul style="list-style-type: none"> Same as Alternatives 1 and 2. 	<ul style="list-style-type: none"> The No Action Alternative would generate lower amounts of CO₂ than Alternatives 1, 2 and 3.

Alternative 1	Alternative 2	Alternative 3 – Preferred Alternative	No Action Alternative
3.3 – Environmental Health			
<p><u>Hazardous Materials</u></p> <ul style="list-style-type: none"> During construction, gas and other petroleum-based products would be utilized. As with any construction, accidental spills could occur. A spill prevention plan would minimize potential for accidental release of hazardous materials to the environment. 	<ul style="list-style-type: none"> Same as Alternative 1. 	<ul style="list-style-type: none"> Same as Alternatives 1 and 2. 	<ul style="list-style-type: none"> The amount of construction and potential for accidental spills would be substantially less than under Alternatives 1, 2 and 3.
<ul style="list-style-type: none"> New development would include hospital and medical office uses and associated increase in use and generation of hazardous materials and waste. Materials/waste would continue to be managed by the University’s Environmental Health and Safety Department. 	<ul style="list-style-type: none"> Same as Alternative 1. 	<ul style="list-style-type: none"> Same as Alternatives 1 and 2. 	<ul style="list-style-type: none"> The use of medical hazardous materials and waste would be similar to current conditions.

Alternative 1	Alternative 2	Alternative 3 – Preferred Alternative	No Action Alternative
<p><u>Noise</u></p> <ul style="list-style-type: none"> Operational noise with new development associated with building systems (e.g. mechanical systems) and traffic noise. New mechanical systems may reduce some existing noise generators. 	<ul style="list-style-type: none"> Same as Alternative 1. 	<ul style="list-style-type: none"> Same as Alternatives 1 and 2. 	<ul style="list-style-type: none"> The amount of new development would be substantial lower than under Alternatives 1, 2 and 3, with noise levels similar to current conditions.
<ul style="list-style-type: none"> Emergency generators require air intakes/exhaust which would allow for some noise to escape the enclosed structure. However, because emergency generators are only utilized in the case of power disruption or during required monthly testing (typically one hour of testing per month), the amount of time the emergency generators would be utilized is anticipated to be low and would be similar to current conditions. 	<ul style="list-style-type: none"> Same as Alternative 1. 	<ul style="list-style-type: none"> Same as Alternatives 1 and 2. 	<ul style="list-style-type: none"> The existing emergency generators would be generally tested and utilized as under current conditions.

Alternative 1	Alternative 2	Alternative 3 – Preferred Alternative	No Action Alternative
3.4 – Aesthetics, Light, Glare & Shadows			
<u>Aesthetics</u> <ul style="list-style-type: none"> The aesthetic character of the campus would reflect a denser development pattern with taller buildings. 	<ul style="list-style-type: none"> Same as Alternative 1. 	<ul style="list-style-type: none"> Same as under Alternatives 1 and 2. 	<ul style="list-style-type: none"> The aesthetic character would be similar to current conditions.
<ul style="list-style-type: none"> Views to the campus would be modified to reflect increased density and building heights. 	<ul style="list-style-type: none"> Similar to Alternative 1 with slightly lower potential for view to tallest buildings with reduced area with 175-foot building height overlay. 	<ul style="list-style-type: none"> Similar to Alternative 2 with slightly lower potential for view to tallest buildings with reduced area with 175-foot building height overlay. 	<ul style="list-style-type: none"> Views to campus would be similar to current conditions.
<u>Shadows</u> <ul style="list-style-type: none"> New buildings and landscaping would result in an increase in shadows. In general, these shadows would be cast over areas that already receive shadows from existing buildings and mature perimeter trees. 	<ul style="list-style-type: none"> Similar to Alternative 1. 	<ul style="list-style-type: none"> Generally similar to Alternatives 1 and 2, with lower level of potential shadow cast from buildings in the northern portion of campus compared to Alternatives 1 and 2 	<ul style="list-style-type: none"> Shadow conditions would be similar to current conditions

Alternative 1	Alternative 2	Alternative 3 – Preferred Alternative	No Action Alternative
		due to lower building height limits.	
<p><u>Light and Glare</u></p> <ul style="list-style-type: none"> New sources of light and glare would be generated from vehicles traveling through and adjacent to campus, light from new buildings and parking areas, and sunlight reflecting off new building surfaces. All development under the Draft 2024 MIMP Update would comply with the University’s design review process, which includes consideration of measures to reduce light and glare. 	<ul style="list-style-type: none"> Similar to Alternative 1. 	<ul style="list-style-type: none"> Similar to Alternatives 1 and 2, with lower potential for vehicle light and glare due to no potential for vehicle use of driveway access from N 120th Street. 	<ul style="list-style-type: none"> Light and glare conditions would be similar to current conditions.
3.5 – Historic & Cultural Resources			
<ul style="list-style-type: none"> There are no buildings on or adjacent to the site that are listed on the NRHP or as a City of Seattle Landmark and no direct or indirect impacts 	<ul style="list-style-type: none"> Same as Alternative 1. 	<ul style="list-style-type: none"> Same as Alternatives 1 and 2. 	<ul style="list-style-type: none"> Same as Alternatives 1, 2 and 3.

Alternative 1	Alternative 2	Alternative 3 – Preferred Alternative	No Action Alternative
to listed historic resources would be anticipated.			
<ul style="list-style-type: none"> The campus area is considered a moderately low risk for archaeological resources and the likelihood for cultural resource impacts is anticipated to be low. 	<ul style="list-style-type: none"> Same as Alternative 1. 	<ul style="list-style-type: none"> Same as Alternatives 1 and 2. 	<ul style="list-style-type: none"> Same as Alternatives 1, 2 and 3.
3.6 – Transportation			
<u>Construction</u> <ul style="list-style-type: none"> Construction would generate traffic associated with deliveries and workers. Closure of City right-of-way would not be anticipated. 	<ul style="list-style-type: none"> Same as Alternative 1. 	<ul style="list-style-type: none"> Same as Alternatives 1 and 2. 	<ul style="list-style-type: none"> The amount of construction and potential for traffic would be less than under Alternatives 1, 2 and 3.
<u>Trip Generation</u> <ul style="list-style-type: none"> Development would result in net new increase of approximately 662 trips during the weekday AM peak hour and 563 trips during the PM peak hour relative to No Action. 	<ul style="list-style-type: none"> Same as Alternative 1. 	<ul style="list-style-type: none"> Same as Alternatives 1 and 2. 	<ul style="list-style-type: none"> Development under existing MIMP capacity would result in net new increase of approximately 29 trips during the weekday AM

Alternative 1	Alternative 2	Alternative 3 – Preferred Alternative	No Action Alternative
			peak hour and 24 trips during the PM peak hour ² .
<p><u>Traffic Operations</u></p> <ul style="list-style-type: none"> Two intersections would operate poorly (LOS E or F) during the AM peak hour with five intersections operating poorly during the PM peak hour. 	<ul style="list-style-type: none"> Same as Alternative 1. 	<ul style="list-style-type: none"> Same as Alternatives 1 and 2. 	<ul style="list-style-type: none"> One intersection would operate poorly during the AM peak hour with three intersections operating poorly during the PM peak hour.
<p><u>Campus Access</u></p> <ul style="list-style-type: none"> The proposed third access under either option (N 115th Street or N 120th Street) would operate at LOS A with limited queuing. 	<ul style="list-style-type: none"> Same as Alternative 1. 	<ul style="list-style-type: none"> The proposed third access would be from N 115th Street (no optional access from N 120th Street) and would operate at LOS A with limited queuing. 	<ul style="list-style-type: none"> No 3rd access included in existing MIMP.
<p><u>Pedestrian/Bicycle</u></p> <ul style="list-style-type: none"> Pedestrian and bicycle trips would increase. Features to improve bicycle and pedestrian conditions are 	<ul style="list-style-type: none"> Same and Alternative 1. 	<ul style="list-style-type: none"> Same as Alternatives 1 and 2. 	<ul style="list-style-type: none"> Pedestrian and bicycle improvements would be less than under Alternative 1, 2 and 3.

² Does not include trips associated with the Behavioral Health Building (120 AM peak hour and 73 during PM peak hour).

Alternative 1	Alternative 2	Alternative 3 – Preferred Alternative	No Action Alternative
included in the Draft 2024 MIMP Update.			
3.7 – Utilities			
<p><u>Water Supply</u></p> <ul style="list-style-type: none"> New development would require new connections and would increase demand on the water supply system. New development would utilize efficient fixtures and other water saving features as appropriate. As individual projects are proposed, specific analyses would be conducted to identify specific requirements. 	<ul style="list-style-type: none"> Same as Alternative 1. 	<ul style="list-style-type: none"> Same as Alternatives 1 and 2. 	<ul style="list-style-type: none"> Buildout of the remaining 1991 MIMP capacity would result in increased demand on the water system, although at a lower level than under Alternatives 1, 2 and 3.
<p><u>Sewer</u></p> <ul style="list-style-type: none"> New development would increase demands to the existing sewer system. As individual projects are proposed, side sewer evaluations would be completed to verify capacity 	<ul style="list-style-type: none"> Same as Alternative 1. 	<ul style="list-style-type: none"> Same as Alternatives 1 and 2. 	<ul style="list-style-type: none"> Buildout of the remaining 1991 MIMP capacity would result in increased demand on the sewer system, although at a lower level than under Alternatives 1, 2 and 3.

Alternative 1	Alternative 2	Alternative 3 – Preferred Alternative	No Action Alternative
and identify necessary improvements.			
<p><u>Stormwater</u></p> <ul style="list-style-type: none"> New development would result in an overall increase in impervious surfaces and as specific development projects occur, each project would be required to meet the applicable requirements of the City of Seattle’s Stormwater Manual. 	<ul style="list-style-type: none"> Same as Alternative 1. 	<ul style="list-style-type: none"> Same as Alternatives 1 and 2. 	<ul style="list-style-type: none"> Minimal change to impervious surfaces anticipated.
3.8 – Construction Impacts			
<ul style="list-style-type: none"> Construction activities could occur throughout the development envelope (established by the building height overlays and perimeter building setbacks) and would include: removal of existing buildings, pavement and landscaping; excavation and grading; and, construction of health care service buildings. 	<ul style="list-style-type: none"> Same as Alternative 1. 	<ul style="list-style-type: none"> Same as Alternatives 1 and 2. 	<ul style="list-style-type: none"> The level of construction activities would be substantially less than under Alternatives 1, 2 and 3.

Alternative 1	Alternative 2	Alternative 3 – Preferred Alternative	No Action Alternative
<p><u>Earth</u></p> <ul style="list-style-type: none"> Construction of buildings would result in approximately 1.5 to 2.9 million cubic yards of excavation (depending on the nature and location of individual projects), and approximately 365,000 cubic yards of fill. 	<ul style="list-style-type: none"> Same as Alternative 1. 	<ul style="list-style-type: none"> Same as Alternatives 1 and 2. 	<ul style="list-style-type: none"> The amount of excavation and fill would be substantially less than under Alternatives 1, 2 and 3.
<ul style="list-style-type: none"> Development could occur in or in proximity to City of Seattle environmentally critical areas (ECA) for Steep Slopes and Landfill (Historical). Any development in proximity to the ECAs would be conducted in compliance with City of Seattle Environmentally Critical Areas regulations (SMC 25.09). 	<ul style="list-style-type: none"> Same as Alternative 1. 	<ul style="list-style-type: none"> Same as Alternatives 1 and 2. 	<ul style="list-style-type: none"> The potential for new development to be located in or in proximity to ECAs would be substantially less than under Alternative 1, 2 and 3.
<p><u>Air Quality</u></p> <ul style="list-style-type: none"> Short-term construction-related air quality increases in particulates and emissions in 	<ul style="list-style-type: none"> Same as under Alternative 1. 		<ul style="list-style-type: none"> The potential for construction related increases in particulates and

Alternative 1	Alternative 2	Alternative 3 – Preferred Alternative	No Action Alternative
the vicinity of the individual project construction sites.			emissions substantially less than Alternatives 1, 2 and 3.
<p><u>Trees</u></p> <ul style="list-style-type: none"> Construction of projects could result in removal of existing lawns, trees and shrubs, including the potential to remove some trees meeting the City of Seattle definition of Tier 2 tree. 	<ul style="list-style-type: none"> Similar to Alternative 1, although slightly higher potential for removal of Tier 2 trees given less area in perimeter setback areas. 	<ul style="list-style-type: none"> Similar to Alternatives 1 and 2, although lower potential for removal of Tier 2 trees given more area in perimeter building setback than under Alternatives 1 and 2. 	<ul style="list-style-type: none"> Potential for removal of lawns, trees (including Tier 2 trees) and shrubs substantially less than under Alternatives 1, 2 and 3.

SUMMARY OF MITIGATION MEASURES AND SIGNIFICANT UNAVOIDABLE ADVERSE IMPACTS

Land Use

Mitigation Measures

Implementation of the proposed design guidance and development standards in the proposed *2024 MIMP Update* would minimize potential land use impacts. These standards include, but are not limited to: building setbacks, visual screening with landscaping at campus edges adjacent to residential land uses, and implementation of the University of Washington (UW) Design and Environmental Review Process, including review by the UW Architectural Commission and SEPA Advisory Committee.

Significant Unavoidable Adverse Impacts

Under Alternatives 1 and 2, intensification in land uses on the UWMC-Northwest campus would occur as a result of increased density and building heights. With proposed mitigation measures, significant unavoidable land use impacts are not anticipated.

Air Quality

Mitigation Measures

The proposed *2024 MIMP Update* includes sustainability design guidelines to create a more sustainable campus environment. These goals would, in part, guide future campus development and would indirectly relate to the overall air quality and GHG environment. In addition to compliance with applicable regulations related to construction and operations (including EPA, PSCAA and City of Seattle regulations), the following potential measures are intended to further reduce the potential for air quality and GHG impacts.

Construction

- Construction-related air quality mitigation measures are identified in **Section 3.8**, Construction Impacts.

Operations

- Air emissions would be consistent with applicable local, State, and Federal regulations, and would be consistent with the University of Washington Environmental Health and Safety Department guidelines.

- Features to minimize the potential for exhaust features in proximity to adjacent residential areas would be considered during the design of individual projects (including the CUP), and would be considered during implementation of the University design and environmental review process.
- Implementation of the proposed Transportation Management Plan would reduce vehicle trips and associated vehicle emissions.

GHG Emissions

- The University of Washington would embrace sustainability as an objective for all development on campus, including LEED provisions. Key measures that could be explored include:
 - installation of high-performance glazing with low-E coatings to further reduce heat gain;
 - considering use of reflective roof surface treatments to reduce 'heat island effect' on building roofs;
 - planting of drought resistant and tolerant planting in landscaped areas to minimize irrigation requirements;
 - maximizing use of outside air for heating, ventilating, and air conditioning;
 - installation of efficient light fixtures, including occupancy and daylight sensors, as well as nighttime sweep controls;
 - use of low flow plumbing fixtures, which could result in a 30 percent reduction of water consumption;
 - use of low VOC emitting materials for finishes, adhesives primers and sealants;
 - incorporation of recycled content and rapidly renewable materials into project designs, including: concrete, steel and fibrous materials (bamboo, straw, jute, etc.);
 - salvage of demolished material and construction waste for recycling; and
 - Commitment to the Seattle 2030 District pilot program to reduce energy and water consumption, as well as CO₂ emissions from auto and freight traffic.

Significant Unavoidable Adverse Impacts

With implementation of the mitigation measures identified above, no significant unavoidable adverse impacts on air quality would be anticipated under the EIS Alternatives. Climate change and other issues associated with GHG emissions is a global issue, and it is

not possible to discern the impacts of the GHG emissions from a single major institution master plan.

Environmental Health

Mitigation Measures

Hazardous Materials

- Potential future development projects under the proposed *2024 MIMP Update* should verify the presence, use and/or potential generation of hazardous materials on the project site prior to development.
- Hazardous materials generated and used on campus would continue to be managed in accordance with existing policies/standards established by the University's Environmental Health and Safety Department, as well as applicable local, state and federal standards/regulations.
- Existing facilities that handle hazardous materials could be improved under the proposed *2024 MIMP Update* to meet future needs and standards.

Noise

- Construction-related noise mitigation measures are identified in **Section 3.8, Construction Impacts**.
- Development projects under the proposed *2024 MIMP Update* that are located in areas that are proximate to noise-sensitive uses could require project-specific coordination with adjacent noise-sensitive users to determine potential noise-related issues associated with development on those sites and could require additional noise analysis and mitigation measures (if necessary).

Significant Unavoidable Adverse Impacts

It is anticipated that an increase in hazardous materials and noise would occur as development occurs under the proposed *2024 MIMP Update*. With implementation of the mitigation measures identified above, no significant unavoidable adverse environmental health impacts would be anticipated under the EIS Alternatives.

Aesthetics, Light, Glare & Shadows

Mitigation Measures

Aesthetics

- Potential future development projects would be consistent with the development guidelines and development standards identified in the *2024 MIMP Update*, including:
 - Provide visual screening to reasonably obscure a view from adjacent properties to campus utility equipment, support service areas, and/or surface parking operations. Screening shall be implemented through the use of vegetation, trees, fences, walls, and other materials. Screening will be maintained.
 - Where the property abuts residential parcels, campus landscaped areas will be maintained to help create a landscape buffer for neighbors. Planting materials will incorporate trees and shrubs to help obscure campus activities and provide privacy.
- The University of Washington’s design review process (architectural and landscape review, and environmental review) would review all building projects and consider aesthetic/views as part of individual projects.

Light & Glare

- The University’s existing design review process (architectural and landscape review, and environmental review) would continue to be used to review all building projects on campus.
- The design of potential future development would consider the use of least reflective glazing available to minimize the effects of reflective solar glare.
- Exterior light fixtures would continue to be shielded and sited to focus lighting and direct light away from adjacent off-campus land uses.

Shadows

- All potential development projects would comply with the University’s design review process and design standards (i.e., architectural review and review and environmental review) which would include a review of building orientation, building height, and associated potential shadows.

Significant Unavoidable Adverse Impacts

Development under the *2024 MIMP Update* would result in changes to the aesthetic character of the campus, including increased density and building heights. The optional new driveway access from N 120th St. would include clearing of existing trees and increased ability to view building development in the center of campus. Implementation of the mitigation measures identified above are intended to minimize the potential for aesthetic impacts. Although the potential for views to building development on campus would increase, the change in view could be interpreted as positive or negative depending on the perception of the individual.

Potential future development under the *2024 MIMP Update* would result in an increase in light and glare on campus associated with new buildings and associated vehicles. With the implementation of the mitigation measures identified above, no significant unavoidable adverse impacts are anticipated.

Potential future development under the *2024 MIMP Update* would result in an increase in shadows on campus associated with new buildings and associated campus landscaping. However, in general these shadows would be cast over areas that already receive shadows from existing buildings and mature trees. With the implementation of the mitigation measures identified above, no significant unavoidable adverse impacts would be anticipated.

Historic & Cultural Resources

Mitigation Measures

Historic Resources

- The University of Washington's existing internal design review processes (architectural, environmental review, and Board or Regents) would continue to review and authorize major building projects in terms of siting, scale, and the use of compatible materials relative to historic structures.
- The University of Washington would continue to follow the Historic Resources Addendum (HRA) process for all proposed projects that include exterior alterations to buildings over 50 years old or are located adjacent to buildings or features over 50 years old. The HRA is intended to ensure that important elements of the campus, its historic character and value, environmental considerations and landscape context are valued.

Cultural Resources

- In the event that archaeological deposits are inadvertently discovered during construction of a development project, ground-disturbing activities would be halted immediately, and the University of Washington shall be notified. The University would then contact DAHP and the interested Coast Salish Native Americans, as appropriate, and as described in the recommended inadvertent discovery plan.
- Any human remains that are discovered during construction at a potential development site would be treated with dignity and respect. DAHP procedures would be followed.
 - If ground-disturbing activities encounter human skeletal remains during the course of construction, then all activity that may cause further disturbance to those remains must cease, and the area of the find must be secured and protected from further disturbance. In addition, the finding of human skeletal remains must be reported to the county coroner and local law enforcement in the most expeditious manner possible. The remains shall not be touched, moved, or further disturbed.
 - The county coroner will assume jurisdiction over the human skeletal remains and make a determination of whether those remains are forensic or non-forensic. If the county coroner determines the remains are non-forensic, they will report that finding to the DAHP. DAHP will then take jurisdiction over those remains and report them to the appropriate cemeteries and affected tribes. The State Physical Anthropologist will make a determination of whether the remains are Indian or non-Indian, and report that finding to any appropriate cemeteries and the affected tribes. The DAHP will then handle all consultation with the affected parties as to the future preservation, excavation, and disposition of the remains.

Significant Unavoidable Adverse Impacts

With implementation of the mitigation measures identified above, no significant unavoidable adverse historic or cultural resource impacts would be anticipated under the EIS Alternatives.

Transportation

Mitigation Measures

- The **Meridian Avenue N/N 115th Street** all-way stop controlled intersection is forecast to degrade from operating at LOS D and E during the AM and PM peak hour No Action 2030 and 2040 conditions, to operate at LOS F during the AM and PM peak hour Alternative 1 2030 and 2040 conditions. This increase in delay at the all-way stop

controlled intersection is identified as a significant impact which will require mitigation. As the current intersection is currently operating as an all-way stop, the proposed mitigation includes the signalization of the intersection. No changes in channelization are proposed with the signalization of the intersection. The timing of this improvement is based on the amount of development occurring and the horizon year that the development is anticipated due to background traffic growth. The following highlights mitigation triggers for this improvement numbers reflect net new square footage to campus. Implementation of a future improvement at this intersection is subject to SDOT approval at the time of the development trigger.

- | | |
|----------------------------|----------------------------|
| – 2026 – up to 180,000 gsf | – 2031 – up to 110,000 gsf |
| – 2027 – up to 170,000 gsf | – 2032 – up to 95,000 gsf |
| – 2028 – up to 155,000 gsf | – 2033 – up to 80,000 gsf |
| – 2029 – up to 140,000 gsf | – 2034 – up to 60,000 gsf |
| – 2030 – up to 125,000 gsf | – 2035 – up to 45,000 gsf |

- **Construction Management Plan.** To minimize/reduce impacts to the surrounding neighborhood a Construction Management Plan, consistent with City requirements will be prepared. This plan will include the following elements:
 - Construction hours
 - Noise generating activities
 - Noise sensitive receivers
 - Construction noise management
 - Construction milestones
 - Construction parking
 - Right-of-Way use – (e.g. street closures, sidewalk closures, transit stop closures/relocations, etc.)
 - Haul Routes

Significant Unavoidable Adverse Impacts

The LOS at the 1st Avenue NE/N 130th Street intersection is forecast to degrade from operating at LOS D under future (2040) No Action weekday PM peak hour conditions to LOS E with Alternative 1, with an increase in delay of approximately 7 seconds. This exceeds the typical threshold of 5 seconds for identifying significant impacts. The reduced operations are associated with the proposed channelization revision along the N 130th Street corridor as part of the Vision Zero safety corridor project which prioritizes the implementation of non-motorized facilities including installing bicycle lanes along both sides of the road. This is accomplished by reducing N 130th Street from 4 vehicular lanes to a three-lane road (two

through-lanes with a center two-way left turn lane) west of 1st Avenue NE. Given the planned improvement at this location to reduce the vehicular capacity, prioritizing non-motorized, an improvement to increase vehicular capacity at this location is not proposed.

No additional significant and unavoidable adverse impacts have been identified through this analysis.

Non-Motorized Connectivity Improvements

- To improve connectivity to the transit stops located along Meridian Avenue N at N 120th Street, UWMC-Northwest will construct curb, gutter, and sidewalk along the south side of N 120th Street between Meridian Avenue N and west to the existing improved section. The section to be constructed is anticipated to generally match what was constructed along the UWMC northern frontage. Final plans and construction of the planned improvements are dependent upon future SDOT approval. These improvements would be triggered in the future when the hospital increases the patient occupiable area by greater than 250,000 net new gsf; resulting in increases in patient volume and increased trip volume (i.e. size excludes the central utility plant and parking).

Utilities

Mitigation Measures

Water

- Use of low- or no-flow fixtures and other water saving devices would be utilized as feasible.
- Collection and re-use of stormwater for non-potable uses (i.e. irrigation, etc.) would be utilized as feasible to reduce public water supply demand.
- Drip watering or low precipitation systems would be utilized as feasible for irrigation, and types of ground cover that require less irrigation could continue to be utilized.

Sewer

- New connections to the onsite side sewers or new connections to the adjacent sewer mains would need to have a side sewer evaluation completed to verify that the system and services have the capacity to serve each specific new development project.

Stormwater

- Per the 2020 COSSM, any new development projects that include over 2,000 square feet of new and replaced hard surface will need to meet the wetland protection standard, pre-developed pasture standard, and peak control standard flow control requirements from the COSSM.
- Specific development projects with greater than 5,000 square feet of new or replaced pollution generating hard surfaces would be required to provide enhanced water quality treatment for those areas.
- Specific development projects with more than 1,500 square feet of new and replaced hard surface or 7,000 square feet of land disturbing activity would be required to meet OSM requirements for the entire project area.
- Geotechnical reports would be prepared for individual projects to identify specific geology and soils conditions at the site, and determine the feasibility of implementing stormwater infiltration BMPs (including rain gardens and/or other infiltration methods).
- Low-Impact Demand design features could be considered during design of individual projects to minimize stormwater runoff quantity and would be considered during implementation of the University of Washington (UW) Design and Environmental review process, including review by the UW Architectural Commission and SEPA Advisory Committee.

Significant Unavoidable Adverse Impacts

With implementation of the identified mitigation measures, significant utility related impacts are not anticipated.

Construction Impacts

Mitigation Measures

Earth

- All earthwork and site preparation on the UWMC-Northwest campus would be conducted in compliance with relevant grading criteria of the Seattle Municipal Code (Sections 22.170 and 22.802).
- The following Temporary Erosion and Sedimentation Control (TESC) measures would be implemented, as appropriate for the individual sites, as part of code compliance to reduce the risk of construction-related erosion:

- The ground surface in the construction area would be sloped and sealed to reduce water infiltration, to promote rapid runoff, and to prevent water ponding.
 - To prevent soil disturbance, the size or type of construction equipment may have to be limited.
 - No soil would be left uncompacted and exposed to moisture. A smooth-drum vibratory roller, or equivalent, would be used to seal the ground surface.
 - Work areas and soil stockpiles would be covered with plastic. Bales of straw and/or geotextile silt fences would be used as appropriate to control soil erosion.
 - During periods of wet weather, excavation and fill placement would be observed by a geotechnical engineer (or engineer's representative) experienced in wet weather earthwork to determine that unsuitable materials are removed and that suitable compaction and site drainage is achieved.
 - Excavation slopes would be protected from infiltration and erosion by directing water away from excavations and covering slopes with impermeable membranes, such as plastic sheeting.
 - Excavated materials, stockpiles, and equipment would be placed away from the top edge of excavations a distance equal to at least the depth of the excavation.
 - To prevent an accumulation of dust and/or mud on campus during construction activities, the tires of construction equipment and trucks could be washed before they leave construction sites and streets could be swept as necessary.
- Site specific geotechnical recommendations would be provided as individual projects are proposed. Typical measures that could be implemented as part of code compliance, based on the specific conditions at the individual sites, include:
 - Excavations greater than four feet in height would be adequately sloped or braced to prevent localized sloughing and spalling.
 - Temporary shoring would be implemented during construction and would consist of a conventional soldier pile and lagging system.
 - All soil excavated from the site would be tested for contamination. All soil would be disposed of consistent with applicable University of Washington, State and local regulations.
 - Soldier piles and/or other slope stability techniques could be used as necessary in areas of unstable soils.
 - Structures could be designed with structural systems capable of supporting code-required floor loading and resisting lateral forces generated by earthquakes and wind.

- Whenever possible, construction could be scheduled to minimize overlapping of excavation periods for projects.
- Construction activities conducted in portions of the campus identified as containing earth-related environmentally critical areas (in the northwest corner of campus and in proximity to the Medical Office Building in central campus) identified by the City of Seattle Municipal Code (SMC) would comply with applicable development standards for: Steep Slope Areas (SMC 25.09.180); and, Landfills (Historical) (SMC 25.09.220)

Air Quality

- During construction, applicable best management practices (BMPs) to control dust, vehicle and equipment emissions would be implemented.
- Building construction and demolition would be conducted in compliance with Seattle Municipal Code Section 15.22.060B which provides criteria related to suppression of dust-generating activities.
- Where appropriate, temporary asphalt roadways would be provided as part of construction to reduce the amount of dust and dirt that would be generated.
- As applicable, a Construction Management Plan would be prepared for each individual construction project to establish parking areas, construction staging areas, truck haul routes, and provisions for maintaining pedestrian and vehicle routes. These measures are intended to, among other things, minimize traffic delays and associated vehicle idling.
- As applicable, control measures in the Washington Associated General Contractors *Guide to Handling Fugitive Dust from Construction Projects* would be used, including:
 - using only equipment and trucks that are maintained in optimal operational condition;
 - requiring all off-road equipment to have emission reduction equipment (e.g., require participation in Puget Sound Region Diesel Solutions, a program designed to reduce air pollution from diesel, by project sponsors and contractors);
 - implementing restrictions on construction truck and other vehicle idling (e.g., limit idling to a maximum of 5 minutes);
 - spraying exposed soil with water or other suppressant to reduce emissions of PM and deposition of particulate matter;

- covering all trucks transporting materials, wetting materials in trucks, or providing adequate freeboard (space from the top of the material to the top of the truck bed), to reduce PM emissions and deposition during transport;
- providing wheel washers to remove particulate matter that would otherwise be carried off-site by vehicles in order to decrease deposition of particulate matter on area roadways; and
- covering dirt, gravel, and debris piles as needed to reduce dust and wind-blown debris.

Noise

- Construction activities would comply with the City of Seattle Noise Ordinance (SMC 25.08.425) which allows for temporary increases in the maximum permissible sound levels based on equipment type.
- The UWMC-Northwest also has additional conditions/considerations that project-specific contractors meet the following noise control criteria:
 - The use of electric equipment and machinery is preferred. If noise levels on any equipment or device cannot reasonably be reduced to criteria levels, either that equipment or device will not be allowed on the job or use times will have to be scheduled subject to approval.
 - The sound pressure level of each piece of equipment cannot be greater than 85 dBA at a distance of 50 feet. Rubber-tired equipment is to be used whenever possible instead of equipment with metal tracks. Mufflers for stationary engines are to be used in the hospital areas and areas within 100 feet of the campus boundary. Construction traffic should be routed through nearest campus exit.
 - Air compressors are to be equipped with silencing packages.
 - Jack hammers and roto hammers may be used where no other alternative is available; core drilling and saw cutting equipment is preferred.
 - Specific scheduling of construction-related noise activities is required at the UWMC-Northwest Hospital.

Trees

- A detailed Urban Forest management Plan is under development for the campus that will document existing trees and provide standards for preservation and enhancement of trees on campus.

- Replacement of each Tier 2 tree removed in association with development with a tree or trees that will provide the same canopy coverage at maturity unless the removed tree qualifies as a hazardous tree.

Significant Unavoidable Adverse Impacts

With implementation of the identified mitigation measures, significant construction related impacts are not anticipated.

PROJECT DESCRIPTION

CHAPTER 2

INTRODUCTION AND DESCRIPTION OF THE PROPOSED ACTION AND ALTERNATIVES

This chapter of the Final Environmental Impact Statement (EIS) provides a discussion of the UW Medical Center (UWMC) system, information on the UWMC-Northwest campus and surrounding area, planning activities conducted in support of the proposed *UWMC-Northwest 2024 Major Institution Master Plan Update (2024 MIMP Update)*, and a description of the Environmental Impact Statement (EIS) Alternatives. A detailed description of the affected environment, environmental impacts, mitigation measures and significant unavoidable adverse impacts is provided in **Chapter 3** of the September 5, 2023 Draft EIS. Information added or changed subsequent to issuance of the Draft EIS is shaded to ease identification of the added or changed information.

Based on analysis conducted for the Draft EIS, and on comments received from the public and agencies on the Draft *2024 MIMP Update* and Draft EIS, certain revisions to the *2024 MIMP Update* have been made that relate to the EIS Alternatives, including:

- Identification of an additional EIS Alternative (Alternative 3 – Preferred Alternative).
- Additional guidance and standards for the campus loop road.

2.1 Proponent and Project Location

Proponent

The proposed *2024 MIMP Update* is sponsored by the UWMC-Northwest.

Project Location

The UWMC-Northwest campus is located in North Seattle between Highway 99 (Aurora Avenue) and I-5. The campus boundary (also referred to as the Major Institution Overlay (MIO) boundary) encompasses an area of approximately 33 acres. The campus extends from N 115th Street on the south, N 120th Street on the north, approximately Meridan Avenue N on the east, and the Stendall Place residential development and Bikur Cholim Cemetery on the west. **Figure 2-1** presents a regional map and **Figure 2-2** presents a vicinity map.



UWMC-Northwest Photo

UWMC-Northwest 2024 Major Institution Master Plan Update Final EIS

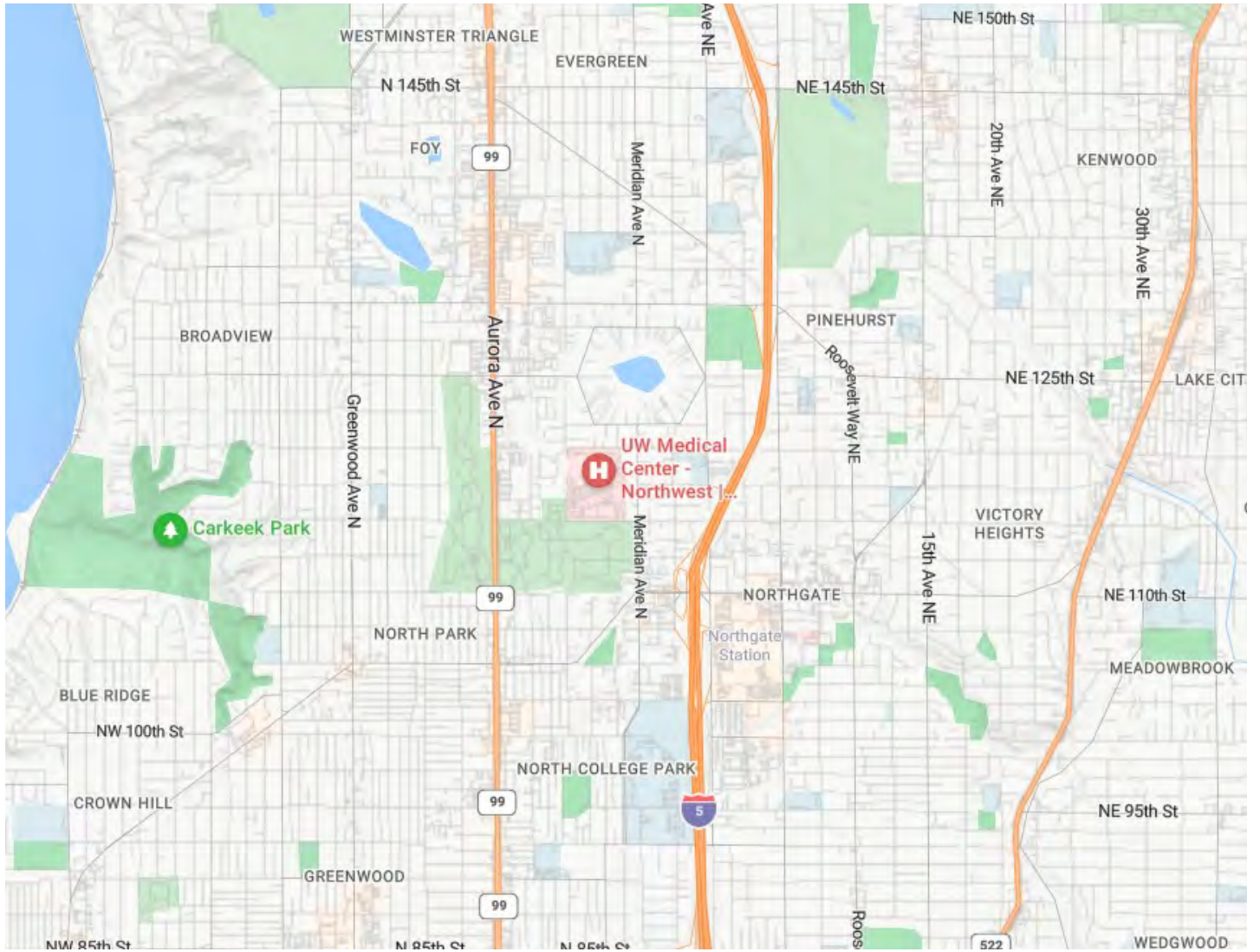

Note: This figure is not to scale.



Source: Bing Maps and EA Engineering 2023



Figure 2-1
Regional Map

UWMC-Northwest 2024 Major Institution Master Plan Update Final EIS



Source: Google Earth and EA Engineering 2023

Figure 2-2
Vicinity Map

2.2 Overview and Proposed Action Need Summary

Overview

The UWMC has two medical centers: the UWMC-Montlake at the University of Washington Seattle Campus and the UWMC-Northwest in North Seattle. The two campuses provide comprehensive healthcare services under a single hospital license. A brief description of each medical center follows.

UWMC-Montlake is directly adjacent to the University of Washington Seattle campus and included within the University of Washington’s major institution overlay. The Montlake campus focuses on specialized, quaternary care which includes complex surgeries, treatments, and procedures.

UWMC-Northwest was built in 1960¹, became a part of the UW Medical Center system in 2010, and became UWMC-Northwest in 2020. The 33-acre medical center is a full-service medical center offering emergency care and a variety of inpatient and outpatient healthcare services. Patients from many communities across King and south Snohomish Counties come to UWMC-Northwest, with access from I-5 and Highway 99. UWMC-Northwest plays a critical, regional role in providing the full spectrum of community-based medical care, particularly in the areas of Cancer Care, Behavioral Health, Cardiology, Spine, Orthopedics, General Surgery, Obstetrics, and Emergency services.

Proposed Action Need Summary

The UWMC-Northwest campus is within the City of Seattle MIO. The MIO is intended, among other things, to permit appropriate institutional growth within boundaries while minimizing the adverse impacts associated with development, balance a major institution’s ability to change with need, to protect adjacent neighborhoods, encourage the concentration of institutions on existing campuses, and provide for coordinated growth through MIMPs (SMC 23.69).

The first MIMP for UWMC-Northwest was adopted by the Seattle City Council in November 1991 (Ordinance 115914)¹. The 1991 Final Adopted Master Plan included provisions for: Campus Boundary; Building Development; Building Heights; Setbacks; Access; and Landscaping.

Table 2-1 lists the level of building space (gross square feet), building height (in feet) and setbacks from the campus boundary (in feet) under the 1991 MIMP and level of current development on the campus. As indicated in the table, total building space on the UWMC-

¹ UWMC-Northwest was originally referred to as Northwest Hospital.

Northwest campus is currently 738,600 sq. ft. compared to the 764,600 sq. ft. capacity allowed under the 1991 Master Plan; thus, the campus has essentially reached the capacity established under the 1991 MIMP (approximately 26,000 sq. ft of additional building space capacity remaining). Existing campus building heights and setbacks are consistent with the limits established by the 1991 MIMP.

**TABLE 2-1
1991 MASTER PLAN AND CURRENT CAMPUS DEVELOPMENT**

	1991 Master Plan	Current Campus Conditions
Total Campus Acreage	33	33
Total Campus Building Space Capacity	764,600 sq. ft.	738,600 sq. ft. ¹
Maximum Building Height	37, 50, 105 feet	12 to 90 feet ¹
Setbacks from Campus Boundary	30, 40, 120, 180 feet	30, 40, 120, 180 feet

Source: UWMC-Northwest, January 2023.

¹ Includes the Behavioral Health Teaching Facility currently under construction.

With the evolving nature of health care needs subsequent to the 1991 Master Plan, the UWMC-Northwest has identified several factors that result in the need for more building space on campus, including:

- Regional Population Growth** - The Puget Sound region’s population has grown significantly since the last UWMC-Northwest MIMP was approved over 20 years ago. By 2050, the Puget Sound Regional Council has projected that the region will grow by more than 1.5 million people. Local demographics directly correlates to the increased demand for healthcare services and expansion of existing healthcare facilities. UWMC anticipates this demographic trend will continue and has adequately planned to accommodate these healthcare demands as part of the growth projections and long-term planning.
- Local Service Area Population Growth & Aging** -The UWMC-Northwest service area spans King and Snohomish Counties which is home for approximately 3.2 million residents. This area is experiencing rapid population growth and is projected to increase by 28% by 2040, exceeding 4 million people. The demand for healthcare is growing with the local service area’s projected population increase and the need for chronic disease management, as well as primary, preventative, and select specialty

care will need to be met at UWMC - Northwest so that the hospital can continue to serve the community.

In addition to growth, the population projections also identify significant gains in the local service area's aging population. Through 2030, the UWMC-Northwest service region is anticipating a 22% growth in the 65+ age group. This demographic experiences higher demand for healthcare services with more complex care needs.

- **Programmatic Needs** - Inpatient hospital care within the service area of UWMC-Northwest is estimated to double by 2043. From 2023 to 2043, inpatient volumes are anticipated to grow by 103% through a mix of organic (53%) and strategic growth (50%). Outpatient clinical care is estimated to grow by 45% in the same time period, from almost 6 million to 8 million patient visits annually. Significant space is needed at UWMC - Northwest to help meet this demand – in the hospital (inpatient beds, diagnostic and treatment services, support space, and infrastructure) and in the outpatient medical office buildings. According to SG2, a national healthcare services consultant, several inpatient and outpatient service lines provided at UWMC-Northwest are projected to grow and require additional space in the hospital and/ or ambulatory clinics.

UWMC-Montlake provides high-end quaternary care which includes Cardiology, Oncology, Obstetrics, Transplant, and Emergency Services, serving Washington state. UWMC-Northwest plays a critical role in the full spectrum community-based care regionally, particularly in the areas of Obstetrics, Emergency Services, and those listed above. UWMC-Northwest campus growth is key to providing capacity for UWMC highly specialized care for the region and state.

As part of the University's academic medical center, UWMC-Northwest also needs support spaces to accommodate faculty and residents beyond just a community hospital setting. For example, current best practices include break-out rooms for collaboration and discussion near patient care areas so that providers can teach while maintaining patient privacy.

- **Replace (or Renovate) Older Campus Facilities** - Many of the facilities at UWMC-Northwest are more than 50 years old and require significant investment through renovation or replacement to meet contemporary healthcare practices.

Aging infrastructure should be replaced to meet current codes, best practices, and improve energy efficiency. Solutions may include development of a central utility plant (or multiple smaller structures) to improve campus operations and comply with the University's sustainable practices. Seismic resilience of the older structures will also need to be addressed with new developments to ensure the hospital can maintain patient care and operations after a significant seismic event.

- **Increase Development Density and Functional Efficiencies** - The older, northern half of the campus is dominated by one-story buildings that spread out healthcare functions and increase walking distances between care areas. Modern medical centers are designed to closely locate all diagnosis and treatment areas so that staff proximity and patient care areas are quickly accessed, either on the same floor or on adjoining levels. All UWMC-Northwest hospital areas will need to grow to respond to the projected population.

In order to allow UWMC-Northwest to address health care needs associated with regional/local population growth, demographic changes (including aging population), evolving academic needs, upgrading older health care facilities, and increasing operational efficiencies, the University of Washington is proposing an update to the 1991 MIMP (see **Section 2.4** for detail).

2.3 Current Campus and Surrounding Area Conditions

Existing Campus

The UWMC-Northwest campus is located within the City of Seattle designated Northgate Urban Center in the Seattle Comprehensive Plan, and within a Major Institution Overlay (MIO) in the City zoning code. The campus underlying zoning is LR2, with height limits as defined by the 1991 MIMP of 37 feet (northern portion of campus), 50 feet (eastern portion of campus), and 105 feet (southern and central portions of campus).



Existing Campus

Existing building setbacks along the perimeter of the campus, as defined by the 1991 MIMP, include a 30-foot setback along the western and southern campus boundaries, 40-foot setback along the majority of the eastern campus boundary, and 120- to 180-foot setbacks along the northern campus boundary and a portion of the campus eastern boundary.

The UWMC-Northwest approximately 33-acre campus currently contains ten buildings connected by vehicular driveways and sidewalks, with a mix of surface and structured parking. Existing buildings range from one to six stories in height, with the majority of the buildings constructed in the 1960s with subsequent modifications (see **Figure 2-3**). The campus currently contains approximately 738,600 sq. Ft. in building space, including the Acute-Care Hospital (A-Wing), Surgical Services/Childbirth (B-Wing), Administration Building (D-Wing), Extended Care Facility (E-Wing), Specialty Center (Procure), Behavioral Health Teaching Facility, and three medical office buildings (see **Table 2-2**). A structured parking garage, surface parking lots, paved sidewalks and walkways, and interior and perimeter landscaping comprise the remainder of the campus area.

**UWMC-Northwest 2024 Major Institution Master Plan Update
Final EIS**

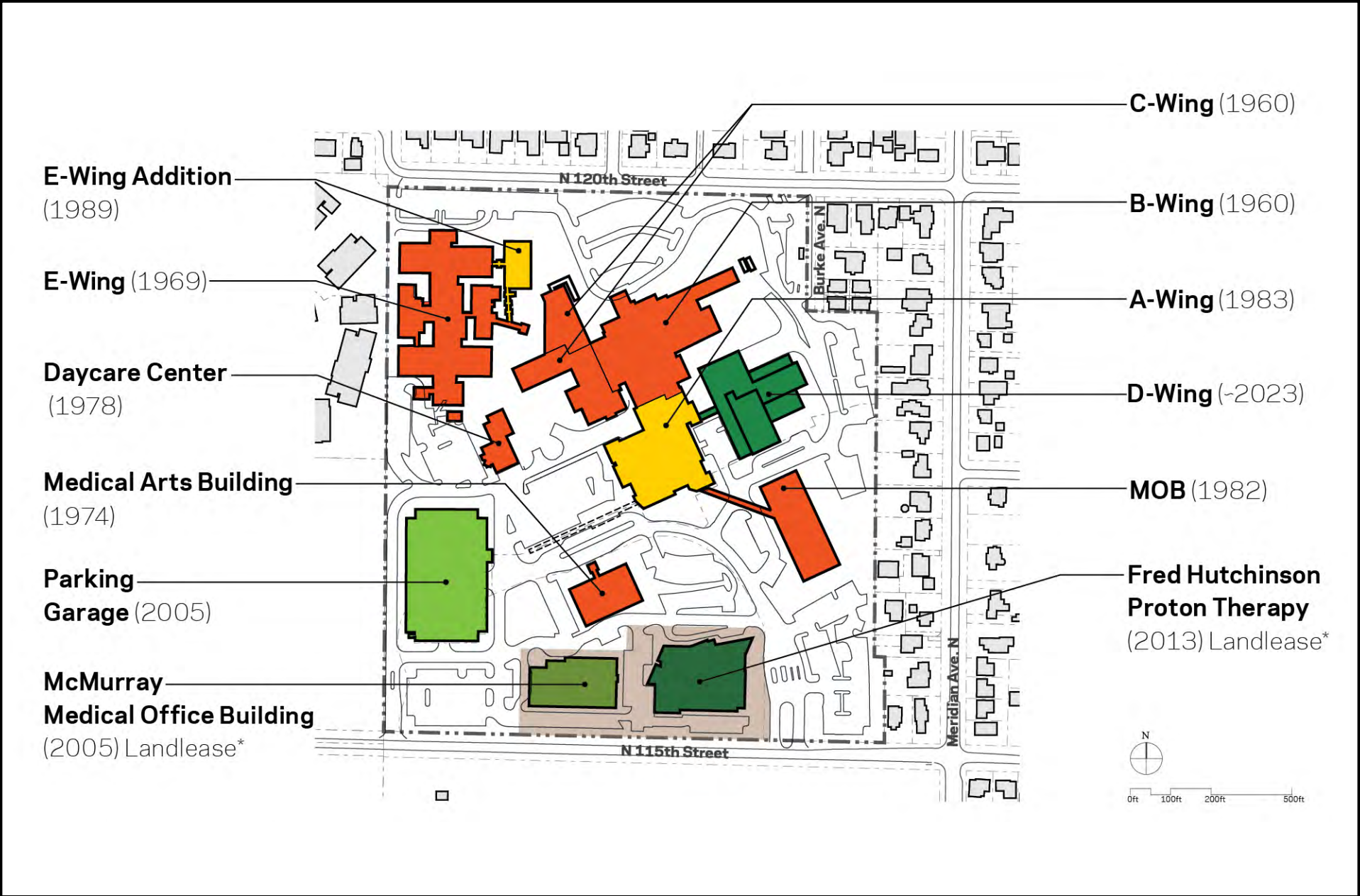

Source: NBBJ 2023

Figure 2-3
Existing Campus Buildings

The existing buildings are mostly separate structures, with the exception of the multiple wings of the hospital complex (A-Wing, B/C-Wings, and the Behavioral Health Teaching Facility); this portion of the medical center contains all of the UWMC-Northwest’s total of 381 licensed hospital beds. A skybridge connects the Medical Office Building to A-Wing. Two building located along the southern boundary of the campus (McMurry Medical Office Building and Fred Hutchinson Proton Therapy) are privately owned on leased land from the UW (see **Figure 2-3** and **Table 2-2**).

The UWMC-Northwest campus currently contains a total of 1,618 parking stalls distributed throughout the campus in a parking structure and several surface lots. The main public vehicular entrance to the UWMC-Northwest campus is provided from N 115th Street, which provides access for patients, visitors, emergency/service vehicles, and transit. A second access from N 115th Street provides keycard-controlled access for employees. A locked emergency/secondary access is provided from N 120th Street.²

**TABLE 2-2
EXISTING CAMPUS BUILDING CHARACTERISTICS**

Existing Building	Building Area (Sq.Ft.)	Building Levels	Building Height (ft.)
Hospital			
A-Wing	128,314	5	72
B-Wing	92,624	1+basement	12
C-Wing	39,508	1+basement	12-15
Behavioral Health Teaching Facility	188,846	6	90
E-Wing	54,408	1	12
Medical Office Building	70,202	2+basement	44
Medical Arts Building	38,121	3	42
McMurry Medical Office Building	63,909	3	45
Fred Huthinson Proton Therapy	57,000	2	36
Daycare Center	5,611	1	12
TOTAL BUILDING SPACE	738,543		
Parking Structure		4	41

Source: UWMC-Northwest, January 2023.

Table 2-3 summarizes existing characteristics of the UWMC-Northwest campus, including building space, hospital beds, impervious (buildings, paved drives and sidewalks, etc.) and pervious (landscaping and natural area) area, campus population, and parking.

² The emergency/secondary access from N 120th Street is controlled by removable bollards.

Campus buildings currently operate separate infrastructure systems (including emergency generators, heat pumps, electrical switch gear, cooling towers, and boilers). The current operation of separate building systems is considered by UWMC-Northwest to be inefficient and costly, and do not provide the appropriate level of back-up.

**TABLE 2-3
EXISTING CAMPUS CHARACTERISTICS**

Campus Acreage	33 acres
Building Space	738,600 sq.ft.
Building Height Maximums	37, 50, 105 feet
Setback from Campus Boundary Required	30, 40, 120, 180 feet
Hospital Beds	353 beds*
Impervious Area	20.36 acres
Pervious Area	12.64 acres
Campus Staff Population	3,150 people
Parking	1,633 spaces

Source: UWMC, 2023.

**Including beds anticipated with opening of the Behavioral Health Teaching Facility.*

Surrounding Area

The area surrounding the UWMC-Northwest campus is primarily residential and open space (cemetery) in character. One- to two-story single family residences comprise the majority of the uses to the north and east of the campus. Two-story multifamily residences (Stendall Place) are located to the west of the campus. Residences in the site vicinity are surrounded by existing mature landscaping and trees. Existing cemeteries are also located to the west and south of the campus, including the Bikur Cholim Cemetery to the west and the Evergreen Washelli Cemetery to the south and southwest (see **Figure 2-2**).

2.4 Major Institution Master Planning Process

Because the building capacity established under the 1991 MIMP is essentially utilized (approximately 26,000 sq. ft. of capacity remaining), the UWMC-Northwest is proposing an updated MIMP to guide future development on the campus to help address health care needs of the region.

The proposed *2024 MIMP Update* represents an update to the original MIMP prepared by UWMC-Northwest³ in compliance with Seattle Municipal Code (SMC) Chapter 23.69 for Major Institution Overlay Districts, as well as to fulfill the need for a comprehensive campus development plan. The MIMP originally was adopted by Seattle City Council in November

³ UWMC-Northwest was referred to as “Northwest Hospital” in 1991

1991 (Ord. 115914), with eight subsequent amendments between 1992-2001 for small changes to individual buildings.

UWMC-Northwest began the process of updating the 1991 MIMP in September 2022 with submittal of a Notice of Intent to the City of Seattle Department of Construction and Inspections (SDCI). The City published a notice about formation of the required Development Advisory Committee (DAC) and recommendations concerning prospective DAC members were approved by the Seattle City Council in March 2023. In December 2022, UWMC-Northwest submitted their proposed *Concept Plan* to SDCI. The DAC orientation occurred in February 2023, and the first working meeting occurred on March 23, 2023. Since then, meetings have been held on a monthly basis. The planning process associated with the UWMC-Northwest *MIMP Update* has involved numerous meetings to encourage broad involvement by numerous entities.

2.5 Environmental Review and Purpose

Consistent with the provisions of the State Environmental Policy Act (SEPA) (RCW 43.21C and WAC 197-11-050), the University of Washington is serving as the lead agency under SEPA (WAC 478-324-010 through -230).

In March 2023, the University of Washington began the formal environmental review process for the proposed *2024 MIMP Update*. As the SEPA lead agency, the University of Washington is responsible for ensuring SEPA compliance. The University determined that the proposed *2024 MIMP Update* could result in significant environmental impacts and that an EIS should be prepared. The University initiated the environmental review process by gathering public and agency input regarding specific topics and issues that should be analyzed as part of this EIS.

On March 27, 2023, the University of Washington issued a Determination of Significance and initiated the scoping process for this EIS. From March 27 through April 17 the University conducted the scoping comment period during which the public, public agencies and tribes were encouraged to provide input regarding the scope of the EIS. During the scoping period, five comment letters and emails were received. The University also held public scoping drop-in sessions on April 1 and 6 and an on-line open house during the comment period. A total of twelve (12) comment letters were received during the scoping comment period.

Based in part on the input received during the scoping period, the scope of the EIS was defined by the University of Washington. The following environmental elements were identified for analysis in the EIS:

- *Land Use/Plans&Policies*
- *Air Quality/GHG*
- *Environmental Health*
- *Aesthetics/Light&Glare/Shadows*
- *Historic/Cultural Resources*
- *Transportation*
- *Utilities*
- *Construction Impacts*

The Draft EIS was published on September 5, 2023 with public and agency comments accepted through October 5, 2023. A public open house on the Draft EIS was held on September 21, 2023. A total of 54 comment letters (including Open House comment forms, letters, and emails) were received on the Draft EIS and Draft *2024 MIMP Update*.

This EIS is intended to address the probable significant adverse impacts that could occur as a result of approval of the proposed *2024 MIMP Update* by the University of Washington Board of Regents and the City of Seattle. A range of alternatives are analyzed in this EIS (see **Section 2.8** later in this chapter) that are intended, in part, to: **1**) encompass a range of focuses for campus development that can reasonably accommodate the projected building space needs; and, **2**) meet the identified MIMP goals and objectives. The alternatives function to provide representative locations of campus development for analysis in this EIS. Although the location and timing of campus development under the proposed *2024 MIMP Update* cannot be specifically defined, Alternatives 1, 2 and 3 are intended to meet the level of building square footages but with different building locations and heights.

The approval of the proposed *2024 MIMP Update* is classified under SEPA as a non-project (also referred to as programmatic) action. A non-project action is defined as an action that is broader than a single site-specific project, and involves decisions on policies, plans, or programs. An EIS for a non-project proposal does not require site-specific analysis; instead, the EIS addresses conditions at a more general level (see WAC 197-11-442 for detail); as possible, the EIS includes detailed information and analysis (e.g., through the use of transportation modeling, greenhouse gas emission calculations; building massing simulations, etc.).

2.6 Major Institution Master Plan Goals (Objectives)

The proposed *2024 MIMP Update* provides a long-term phased development plan that is intended to achieve the following development goals:

- **Accommodate Future Growth.** Accommodate future clinical care growth requirements while maintaining a positive campus experience for patients, visitors, staff, and the community.
- **Align Vision with Strategic Plan.** Align the UWMC - Northwest campus vision with the larger UW Medicine Strategic Plan.

- **Phase Growth for Future Needs.** Replace aging facilities, phase necessary campus expansion, and consider the energy efficiency and utility needs for future development.
- **Create Flexibility to Adapt with Changing Needs.** Create flexibility to support the dynamic, ever-changing healthcare market that allows project sequencing based on need and funding strategies.
- **Provide Community Engagement.** Through clear and transparent communication, ensure the community understands the project vision and can participate in the SEPA process.

2.7 Proposed Action(s)

The proposed *2024 MIMP Update* is being formulated to achieve the Objectives listed in Section 2.6 above. The development contemplated under the proposed *2024 MIMP Update* includes inpatient (hospital) and outpatient clinic buildings to replace and grow existing health care capacity. New support uses such as administrative offices, daycare (for staff families), central utility plant(s), and parking structures are also planned. The Proposed Action involves adoption and implementation of the proposed *2024 MIMP Update*.

Proposed 2024 MIMP Update Features

Campus Boundary

The current campus boundary and size (approximately 33 acres) would not change under the proposed *2024 MIMP Update*. The campus boundary under the proposed *2024 MIMP Update* would remain as illustrated in **Figure 2-3**.

Proposed Building Space

To help meet the health care needs of the region, the proposed *2024 MIMP Update* includes growth in overall building space from the existing approximately 738,600 sq. ft. of building space to up to 1.6 million sq. ft. of building space (reflecting a net increase of approximately 862,000 sq. ft.) over approximately 20 years. Potential development sites for the proposed building projects could be located anywhere on the campus, subject to proposed building height limits, perimeter setback areas, and retained buildings (see **Figure 2-4** for details on retained buildings).

**UWMC-Northwest 2024 Major Institution Master Plan Update
Final EIS**

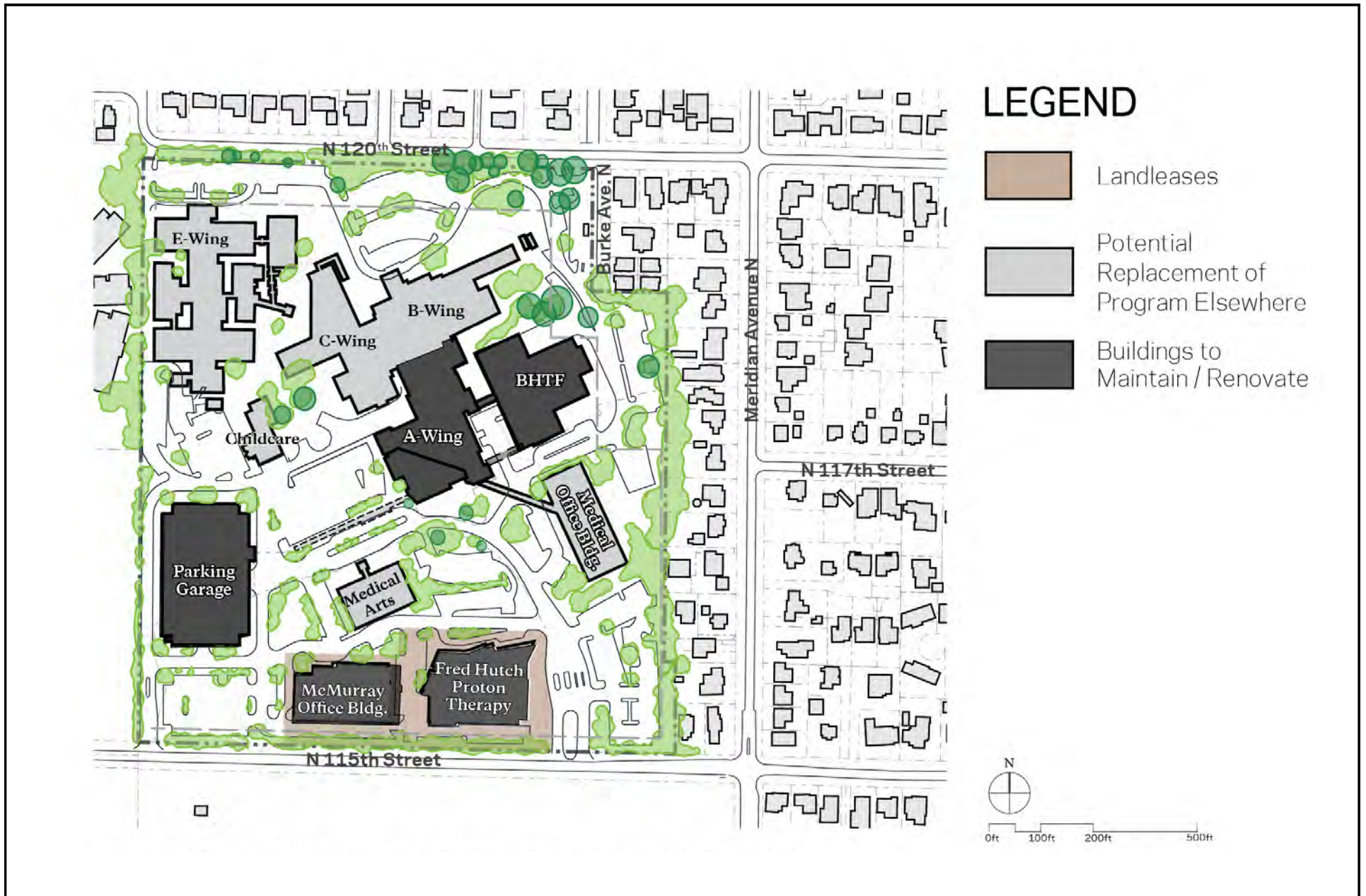

Source: NBBJ 2023

Figure 2-4
Potential Building Replacement

The mix of uses proposed for the UWMC-Northwest campus are consistent with the current campus and the City of Seattle’s definition of a medical center, as they will relate to and support teaching hospital, labs, medical offices, staff services, transportation, open space, food services, childcare, and facilities supporting the utilities and plant maintenance functions.

Example uses could include the following types of infrastructure and growth and/or replacement of medical center functions:

- **Hospital.** Expansion will provide increased capacity for the Emergency Department, operating rooms (ORs), diagnostic and treatment areas, and modern, single occupancy patient rooms in an academic medical care setting. Over time, expansion of the Medical Center would eventually allow the demolition of older hospital structures.
- **Support.** Medical office buildings would help accommodate UWMC needs for outpatient and medical offices. Other support functions may include administrative office needs and a replacement childcare building in a co-located facility, or as separate structures. Potential support building(s) might provide offices, facilities support or workspace for the hospital, including the potential for training facilities for UWMC residents and staff. Any daycare space would entail outdoor play areas for the children in an enclosed, secure playground at grade, or as part of a safe rooftop amenity space.
- **Infrastructure.** Campus buildings currently operate separate building systems which is inefficient and costly. A new central utility plant (CUP) or multiple decentralized plants would replace aging equipment and provide much needed emergency generator capacity. The CUP would be sited and sized to support long-term campus growth, improving the energy efficiency and operating costs of UWMC-Northwest.

Proposed Building Demolition

The proposed *2024 MIMP Update* anticipates several buildings would remain in their current configuration, with on-going maintenance. **Figure 2-4** illustrates these buildings, including the two landleased facilities. **Figure 2-4** also illustrates older structures that may be demolished during implementation of the proposed *2024 MIMP Update*. Potential development sites for building projects could be located anywhere on the campus, subject to proposed perimeter building setbacks and retained buildings.

As listed in **Table 2-4**, one or more existing buildings may be demolished: B/C/E-Wings, Medical Arts Building, Childcare Building, and/or the Medical Office Building. Once functions

can be relocated (on or off-campus), demolition of these buildings could remove up to 301,000 GSF from the campus.

**TABLE 2-4
POTENTIAL BUILDING DEMOLITION**

Existing Building	Number of Stories	Approx. Building Area (Sq.Ft.)
B-Wing	1	92,624
C-Wing	1	39,508
E-Wing	1	54,408
Medical Office Building	2*	70,202
Medical Arts Building	3	38,121
Daycare Center	1	5,611
Total Potential Building Demolition		300,475

Source: UWMC-Northwest. 2023.

*The Medical Office Building includes a basement

Parking and Access

Planned construction of new patient care buildings would increase the number of parking stalls required on campus. On the UWMC-Northwest campus, new construction would also remove existing stalls given that the majority of the available land to build is currently in use as surface parking lots. Parking development would, therefore, need to replace and grow the number of stalls on-campus.

Additional parking may be built as an expansion of the existing parking structure and/or a standalone parking structure(s). A standalone facility may include support uses (clinics, administrative offices or childcare, for example) in front, or as part of, the parking structure. New parking garages would expand electric vehicle charging stations at UWMC-Northwest. [Note: parking structures and basement levels are excluded from area calculations and MIMP limits]. To support the 1.6 million gross sq. ft. of healthcare and support functions at UWMC-Northwest, total parking supply is anticipated to grow from 1,633 stalls to approximately 3,300 stalls in a combination of surface lots and structured parking.

As new projects are developed, UWMC-Northwest would improve site circulation and internal connectivity, particularly routes to the Emergency Department and to ease patient wayfinding. Safety and convenient proximities to care services are of the utmost importance. The new campus loop road would include accessible sidewalks, plantings, and pedestrian lighting to promote a safe, walkable environment for patients, visitors, and staff. The loop road would be developed in phases, as adjacent projects are constructed.

The campus loop road would continue to develop with adjacent projects until the whole campus benefits from an easy, completed circulation path. Each phase of development would ensure safe, clear campus circulation throughout the incremental development of the loop road. Adjacent site areas would be considered for surface parking areas and new landscaped open spaces. Additional circulation improvements anticipated for the campus are described in Section 3.6, **Transportation**.

The majority of the UWMC-Northwest campus access would continue from driveways from N 115th Street. It is assumed that the existing driveways on N 115th Street would be reconfigured to enhance the entry/exit movement for all modes of travel, including the eventual removal of the existing toll booths (east entry off N 115th Street) and existing gate arm (west entry off N 115th Street). Alternatives 1 and 2 assume a new third access point is at one of two optional locations: on N 115th Street immediately west of the McMuray Office Building, near the existing parking garage, or on N 120th Street approximately opposite Densmore Avenue N. Alternative 3 assumes a third access would be from N 115th Street only.

Central Utility Plant

The proposed *2024 MIMP Update* includes a Central Utility Plant (CUP) intended to consolidate and separate the critical infrastructure that supports the Medical Center into a standalone enclosed facility. The proposed CUP, which would be located on campus but outside of the perimeter building setback areas, would allow UWMC-Northwest to expand services over time and perform critical maintenance/replacement with minimal disruption to patient care. Because the proposed CUP would be enclosed and would utilize the latest best management technology, it is anticipated that the levels of operational noise and air emissions would be controlled in a more efficient manner than under current conditions.

The proposed CUP is anticipated to include the equipment listed below⁴.

- Emergency Generators.
- Heat Pumps.
- Electrical Switchgear
- Cooling Towers
- Chillers.
- Boilers
- Medical Air and Vacuum Tanks⁵
- Oxygen Tank⁵

⁴ Additional equipment may be identified as planning for the CUP and individual building projects move forward.

⁵ The oxygen tank would be located adjacent to the CUP structure. The medical air and vacuum tanks is anticipated to be located within the CUP structure.

As under current conditions for individual buildings, emergency generators associated with the proposed CUP would be required to be tested monthly. The duration of each monthly test is anticipated to be approximately one hour, similar to the current emergency generator testing schedule at UWMC-Northwest.

2.8 EIS Alternatives

EIS Alternatives Summary

Because of the evolving nature of health care needs and University of Washington/UWMC funding which requires flexibility to respond to these evolving factors, the proposed *2024 MIMP Update* does not identify specific project locations. Rather, building development under the proposed *2024 MIMP Update* could occur anywhere on campus, but within the building development envelope established by the UWMC-Northwest *2024 MIMP Update* Development Standards (i.e., building height limit overlays and setback areas from the campus perimeter).

Development standards that allow for taller buildings provide opportunities for smaller footprints, enabling the preservation of outdoor open space, integration of mature vegetation and a public realm that provides comfortable circulation routes for all modes of transport. The proposed *2024 MIMP Update* contemplates that the distribution of taller buildings would be concentrated in the core of campus with direct connection to the A-Wing (the primary medical facility). Lower height structures, such as medical office and/or support buildings, parking structures and central utility plant(s) would be located closer to the perimeter of the site, to reduce the scale of development in closer proximity to the adjacent residential development.

Based on analysis conducted for the Draft EIS, and on comments received from the public and agencies on the Draft *2024 MIMP Update* and Draft EIS, an additional EIS Alternative (Alternative 3) has been identified for this Final EIS. Alternative 3 is considered the Preferred Alternative.

In order to conduct a comprehensive environmental review, three development alternatives (Action Alternatives) and a No-Action Alternative have been developed for analysis in this EIS. Because the proposed *2024 MIMP Update* does not identify specific project locations, and building development could occur anywhere on campus, subject to proposed Development Standards (including building height limit overlays, perimeter setback areas, and retained buildings), the three development EIS alternatives (Alternatives 1, 2 and 3) reflect differing building height limit overlays and perimeter building setback areas.

These development EIS alternatives are formulated to create a range of potential development scenarios (without having specific building plans) and allow analysis of probable significant impacts under SEPA. All other features of Alternatives 1, 2 and 3 (such as total net new building space and parking) reflect that in the proposed *2024 MIMP Update* and do not differ between Alternatives 1, 2 and 3. Alternatives 1, 2 and 3 meet the objectives of the UWMC-Northwest.

The No Action Alternative is intended to reflect conditions on the UWMC-Northwest campus if no *2024 MIMP Update* were to be approved, and improvements to address increased health care needs were not implemented. The No Action Alternative does not meet the objectives of UWMC-Northwest.

Alternative 1

Building Space and Demolition

Consistent with the Draft *2024 MIMP Update*, up to approximately 862,000 sq. ft. of net new building space would be developed on the campus; resulting in a total of approximately 1.6 million sq. ft. of building space on campus under Alternative 1. Under Alternative 1, and consistent with the Draft *2024 MIMP Update*, the UWMC-Northwest campus would house up to 515 hospital beds; an increase from the current 353 licensed hospital beds on campus.

Alternative 1 assumes the demolition of up to approximately 301,000 sq. ft. of building space, as listed in Table 2-4 and shown on Figure 2-4. The buildings identified for demolition reflect buildings that are considered unlikely to be efficiently renovated and/or are anticipated to require removal to accommodate new and larger health care facilities.

Building Height Overlays and Perimeter Setback Areas

Alternative 1 reflects a simplified plan for building height limit overlays and perimeter building setback areas intended to maintain development flexibility while preserving existing tree buffers along campus edges (see **Figure 2-5** for assumed Alternative 1 building height limit overlays). Two height limit overlays are assumed under Alternative 1, including:

- 65-feet where abutting parcels developed as residential uses.
- 175-feet for the remainder of the campus.

**UWMC-Northwest 2024 Major Institution Master Plan Update
Final EIS**

Alternative 1

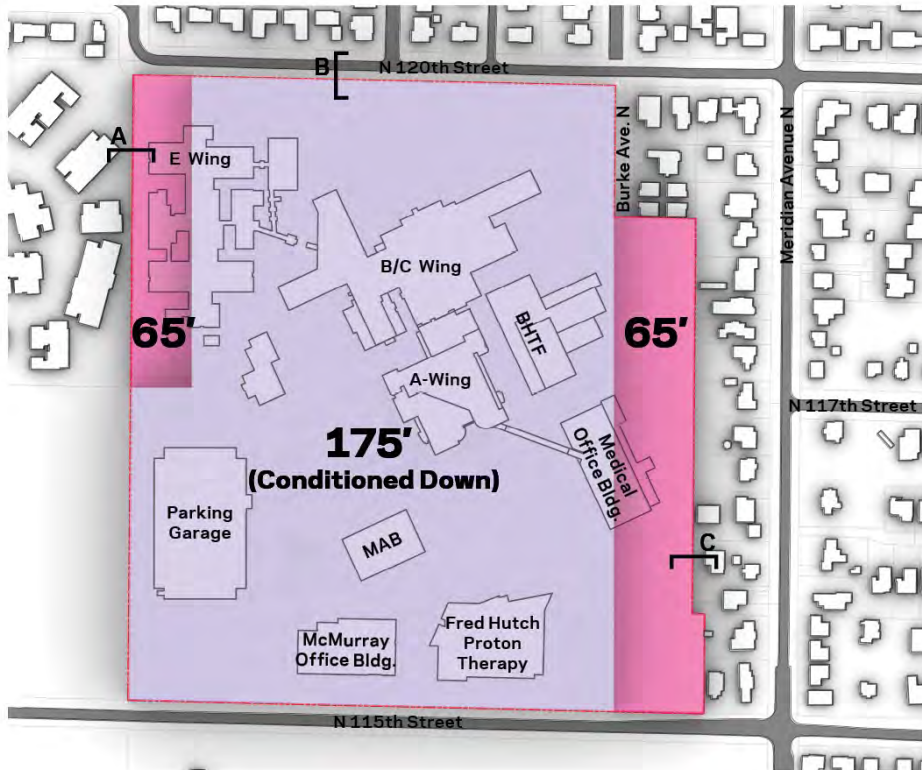

ALTERNATIVE 1 HEIGHT DIAGRAM



- 30' Setback** along rights of way
- 40' Setback** abutting parcels

ALTERNATIVE 1 SETBACK DIAGRAM

Source: NBBJ 2023

Figure 2-5

Alternative 1—Height Limit Overlays and Perimeter Setbacks

Perimeter building setback areas under Alternative 1 are intended to allow for the preservation of the majority of the existing tree canopy and allow UWMC-Northwest to consider different phasing options that respond to community needs and replacement over time (see **Figure 2-5** for assumed Alternative 1 perimeter setback areas). The perimeter setback areas under Alternative 1 are assumed as follows:

- 30-foot setback where campus abuts rights of way (N 115th Street, N 120th Street, and Burke Avenue N).
- 40-foot setback where campus abuts adjacent properties.

Parking and Vehicular Access

Consistent with the Draft *2024 MIMP Update*, new construction under Alternative 1 would increase the demand for parking on campus. In addition, some new construction would likely be located on existing surface lots. New parking would, therefore, be required to replace and grow the number of stalls on-campus. Up to a total of 3,300 stalls are assumed under Alternative 1, an increase of approximately 1,900 stalls over existing conditions. The additional parking would be provided as an expansion of the existing parking structure and/or a standalone parking structure at the south side of campus.

As indicated in the Draft *2024 MIMP Update*, the majority of the UWMC-Northwest campus access would continue from driveways from N 115th Street under Alternative 1. It is assumed that the existing driveways on N 115th Street would be reconfigured to enhance the entry/exit movement for all modes of travel, including the eventual removal of the existing toll booths (east entry off N 115th Street) and existing gate arm (west entry off N 115th Street). A new third access point is assumed to be located on N 115th Street immediately west of the McMurray Office Building, near the existing parking garage. An optional location of the new access on N 120th Street is also considered; this optional access would be located on the south side of N 120th Street opposite Densmore Avenue N.

A campus loop road is proposed to ensure safe, clear campus circulation. The proposed loop road, which would be developed in phases with adjacent building development, may be located within perimeter building setback areas. If located within perimeter building setback areas, the roadway would be located a minimum of 20 feet from property edges abutting residential uses, and substantial vegetated screening would be provided. The posted speed-limit for non-emergency vehicles would be 15 miles per hour or lower.

Alternative 2

Building Space and Demolition

As under Alternative 1 and consistent with the Draft *2024 MIMP Update*, up to approximately 862,000 sq. ft. of net new building space would be developed on the campus; resulting in a total of approximately 1.6 million sq. ft. of building space on campus under Alternative 2. Under Alternative 2, the UWMC-Northwest campus would house up to 515 licensed hospital beds; an increase from the current 353 licensed hospital beds on campus. See **Figure 2-6**.

Alternative 2 assumes the demolition of approximately 301,000 sq. ft. of building space as listed in Table 2-4 and shown on Figure 2-4. The buildings identified for demolition reflect buildings that are considered unlikely to be efficiently renovated and/or are anticipated to require removal to accommodate new health care facilities.

Building Height Overlays and Perimeter Setback Areas

Alternative 2 reflects additional restrictions on building height overlays compared to Alternative 1, including limiting the tallest building height to the central and southwest portions of the campus and adding a mid-range building height limit overlay (105 feet); see Figure 2-6.

The three building height limit overlays assumed under Alternative 2 are as follows:

- *65-feet* at the north/northwest and eastern edges of campus abutting residential parcels.
- *105-feet* in the southwest corner of campus (reflecting existing height limit)
- *175-feet* for the remainder of the campus.

Perimeter building setback areas under Alternative 2 would be narrower than under Alternative 1, and are assumed as follows:

- *20-foot* setback where campus abuts rights of way (N 115th Street, N 120th Street, and Burke Avenue N).
- *30-foot* setback where campus abuts adjacent properties.

Parking and Vehicular Access

Parking and vehicle access would be as described for Alternative 1, including campus loop road and optional third access drives from either N 115th Street or N 120th Street.

UWMC-Northwest 2024 Major Institution Master Plan Update
Final EIS

Alternative 2

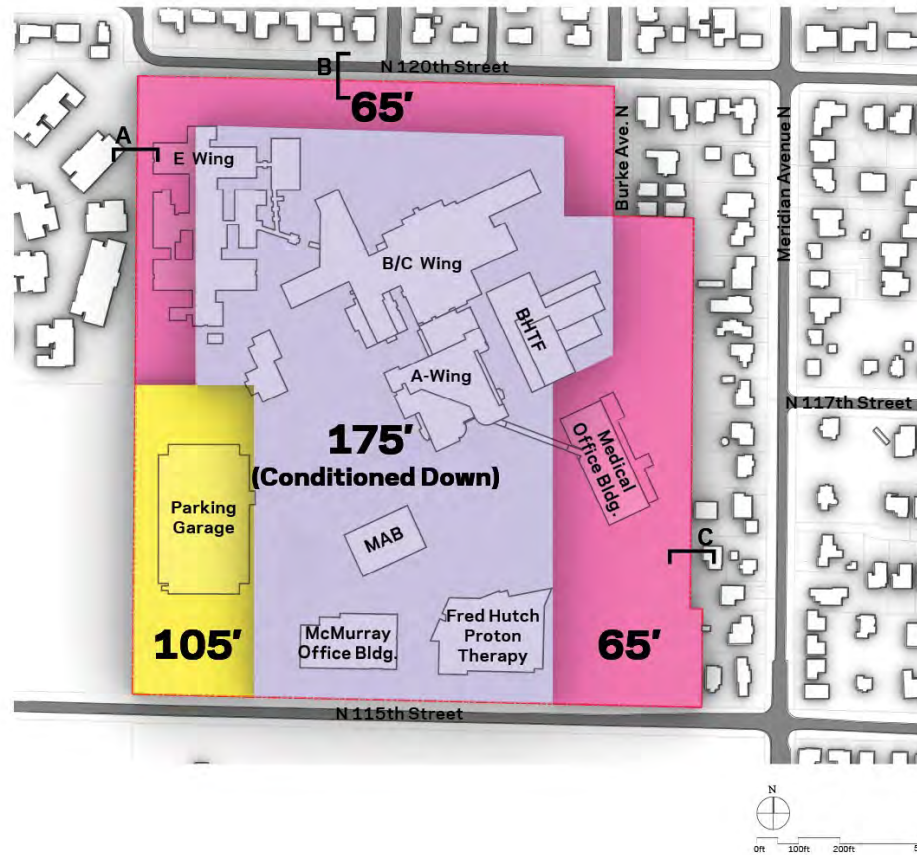

ALTERNATIVE 2 HEIGHT DIAGRAM

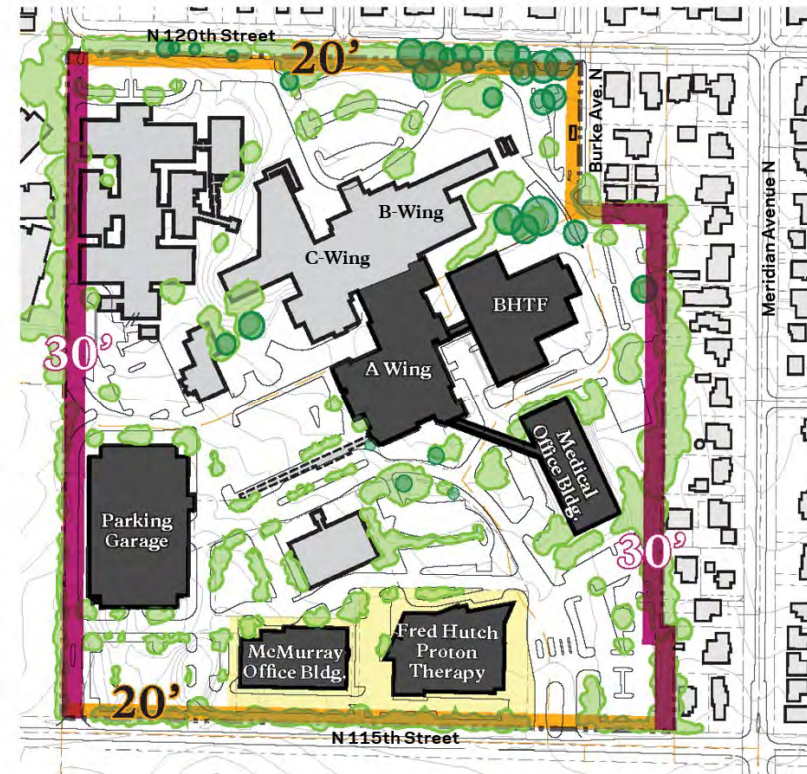

- 20' Setback along rights of way
- 30' Setback abutting parcels

ALTERNATIVE 2 SETBACK DIAGRAM

Source: NBBJ 2023

Figure 2-6

Alternative 2—Height Limit Overlays and Perimeter Setbacks

Alternative 3 – Preferred Alternative

Building Space and Demolition

As under Alternatives 1 and 2 and consistent with the proposed *2024 MIMP Update*, up to approximately 862,000 sq. ft. of net new building space would be developed on the campus; resulting in a total of approximately 1.6 million sq. ft. of building space on campus under Alternative 3. Under Alternative 3, the UWMC-Northwest campus would house up to 515 licensed hospital beds; an increase from the current 353 licensed hospital beds on campus.

As under Alternatives 1 and 2 and consistent with the *2024 MIMP Update*, Alternative 3 assumes the demolition of approximately 301,000 sq. ft. of building space as listed in **Table 2-4** and shown on **Figure 2-4**. The buildings identified for demolition reflect buildings that are considered unlikely to be efficiently renovated and/or are anticipated to require removal to accommodate new health care facilities.

Building Height Overlays and Perimeter Setback Areas

Based on analysis presented in the Draft EIS, and comments received from the Development Advisory Committee, public and agencies on the Draft *2024 MIMP Update* and Draft EIS, Alternative 3 reflects additional restrictions on building height overlays compared to Alternatives 1 and 2, with Alternative 3 reflecting a more layered plan for building height overlays, particularly in the northern portion of campus; see **Figure 2-7**.

Four building height limit overlays are assumed under Alternative 3 as follows:

- *65-feet* at the north, northwest and eastern edges of campus abutting residential parcels and N 120th Street.
- *105-feet* adjacent to N 115th Street and cemetery to the west
- *145-feet* at the north central portion of campus in proximity to residential parcels (additional height overlay limit not included in Alternatives 1 and 2).
- *175-feet* limited to the central portion of the campus.

Perimeter building setback areas under Alternative 3 reflect the widest width setbacks adjacent to residential uses presented in Alternatives 1 and 2, and are assumed as follows:

- *20-foot* setback where campus abuts N 115th Street.

**UWMC-Northwest 2024 Major Institution Master Plan Update
Final EIS**

Alternative 3

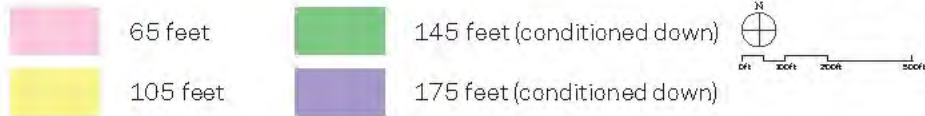
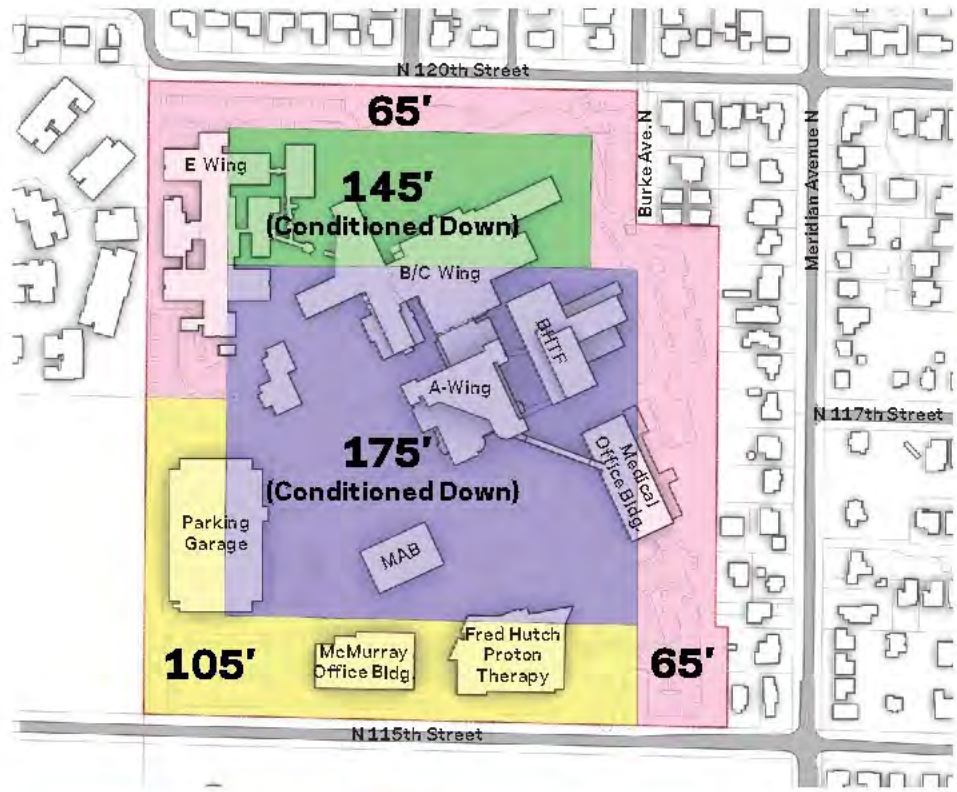

ALTERNATIVE 3 HEIGHT DIAGRAM

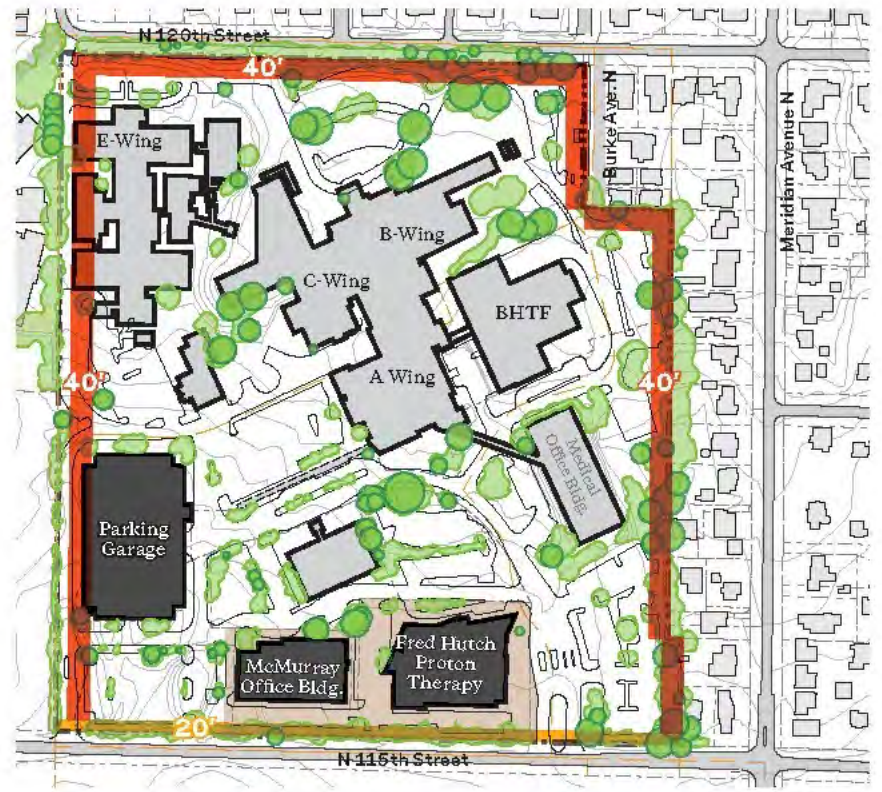

ALTERNATIVE 3 SETBACK DIAGRAM

Source: NBBJ 2023

Figure 2-7

Alternative 3—Height Limit Overlays and Perimeter Setbacks

- 40-foot setback where the campus boundary abuts residential properties to the east and west, and to the north where the campus boundary abuts the N 120th Street right-of-way.

Parking and Vehicular Access

Parking and internal campus circulation, including campus loop road, would be as described for Alternatives 1 and 2, including approximately 3,300 parking spaces. Alternative 3 identifies the third access drive as being from N 115th Street only and does not assume the option of a third access from N 120th Street assumed under Alternatives 1 and 2.

No Action Alternative

Under to No Action Alternative it is assumed that the demand for increases in health care services in the region would continue. However, this EIS alternative would not result in changes to the building height overlays and setbacks, or the physical improvements that are included under the proposed *2024 MIMP Update* (as analyzed under the Proposed Action, and Alternatives 1 and 2), including the addition of approximately 862,000 sq.ft. of net new building space, vehicular access improvements, and new parking. It is anticipated that the approximately 26,000 sq. ft. of remaining campus building capacity under the 1991 Master Plan would be developed, which would accommodate approximately 3% of anticipated demand for health care supporting building space over the next approximately 20 years.

This alternative would not meet the demand for health care in the region and UWMC-Northwest's mission of improving the health of the public.

EIS Alternatives Summary

Alternatives 1 and 2 reflect implementation of the Draft *2024 UWMC-Northwest MIMP Update* and improvements to meet anticipated increased demands for health care services in the region. Alternative 3 is identified for this Final EIS based on comments received on the Draft *2024 MIMP Update* and Draft EIS, and based on analysis prepared for the Draft EIS. The No Action Alternative reflects conditions with no update to the 1991 MIMP. The overall development assumptions under the EIS Alternatives are summarized in **Table 2-5** and include: **1)** campus acreage; **2)** new building space; **3)** total building space; **4)** building height limits; **5)** perimeter setbacks; **6)** number of hospital beds; **7)** amount of impervious surface; **8)** amount of pervious surface/open space; **9)** staff population ; and, **10)** total number of parking stalls.

**TABLE 2-5
COMPARISON OF EIS ALTERNATIVES**

	No Action	Alternative 1	Alternative 2	Alternative 3
Campus Acreage	33 acres	33 acres	33 acres	33 acres
New Building Space	26,000 sq.ft.	862,000 sq.ft.	862,000 sq.ft.	862,000 sq.ft.
Total Building Space	764,600 sq.ft.	1,600,000 sq.ft.	1,600,000 sq.ft.	1,600,000 sq.ft.
Building Height Limits	37, 50, 105 feet	65, 175 feet	65, 105, 175 feet	65, 105, 145, 175 feet
Setback from Campus Boundary	30, 40, 120, 180 feet	30, 40 feet	20, 30 feet	20, 40 feet
Hospital Beds	353 beds	515 beds	515 beds	515
Impervious Area ¹	20.36 acres	23.36 acres	23.99 acres	23.99 acres
Pervious Area ²	12.64 acres	9.50 acres	8.87 acres	8.87 acres
Potential N 120th St. Access	No	Yes	Yes	No
Parking	1,633 spaces	3,300 spaces	3,300 spaces	3,300 spaces

¹Includes area in building footprint, roadways, sidewalks, and plazas.

²Includes area in landscaping and other natural open space.

EIS Alternatives Considered But Not Carried Forward

The Washington State Environmental Policy Act (SEPA), as codified in Washington Administrative Code (WAC) 197-11, indicates that an “EIS shall provide impartial discussion of significant environmental impacts and shall inform decision makers and the public of reasonable alternatives...”.

Reasonable alternatives are defined as “actions that could feasibly attain or approximate a proposal’s objectives, but at a lower environmental cost or decreased level of environmental degradation” (WAC 197-11-435(5)(b)). The word reasonable“ is intended to limit the number and range of alternatives, as well as the amount of detailed analysis for each alternative” (WAC 197-11-435(5)(b)(i)).

Thus, as potential alternatives are identified, they should be measured against the following criteria:

- *Do they feasibly attain or approximate the proposal’s objectives?*
- *Do they provide a lower environmental cost/level of degradation than the proposal?*

The SEPA Handbook Guidelines (Washington State Department of Ecology, 2018) indicates that it may not be evident at the beginning of the process whether an alternative meets all of these criteria, and that the lead SEPA agency should continue to analyze each alternative until information becomes available that indicates an alternative fails to meet the criteria. The alternative can then be eliminated from further consideration.

During the process of identifying reasonable alternatives to be analyzed in the *UWMC-Northwest Campus 2024 MIMP EIS*, the University of Washington (the SEPA lead agency for

this plan) considered a Campus MIMP Update alternative that limited building heights and setbacks to the levels established in the 1991 MIMP. This alternative was measured against the UWMC-Northwest’s objectives, including:

- Accommodating future clinical care growth requirements while maintaining a positive campus experience for patients, visitors, staff, and the community;
- Replacing aging facilities, phasing necessary campus expansion and considering energy efficiency and utility needs for future development; and
- Creating flexibility to support the dynamic, ever changing healthcare market that allows project sequencing based on need and funding strategies.

In considering a potential EIS alternative reflecting existing building heights and setbacks (1991 MIMP) relative to SEPA criteria for EIS alternatives, the University of Washington determined that the building development capacity under an alternative with building heights/setbacks according to the 1991 MIMP could not “reasonably attain or approximate” the identified objective of *accommodating future clinical care growth requirements while maintaining a positive campus experience for patients, visitors, staff and the community*. The limited development capacity under this EIS alternative would also limit the ability to meet the identified objective of *creating flexibility to support the dynamic, ever changing healthcare market that allows project sequencing based on need and funding strategies*. Accordingly, and consistent with SEPA criteria for EIS alternatives, the University of Washington determined that this EIS alternative would not meet project objectives, and is not carried forward for analysis in this EIS.

2.9 Benefits and Disadvantages of Deferring Implementation of the Proposal

The benefits of deferring approval of the Proposed Action and implementation of development of the proposed *2024 MIMP Update* include the deferral of:

- Temporary construction-related impacts associated with vibration, noise, air pollution and traffic.
- Expenditure of funds to create new health care facilities.

The disadvantages of deferring the approval of the Proposed Action and development under the proposed *2024 MIMP Update* include:

- Inability to develop new health care facilities to meet the growing demand for health care services in the region and UWMC-Northwest service area.
- Continued cost associated with maintaining aging facilities.

- Increased cost of building facilities at a later date.
- Continued decline of campus from over-use of existing facilities.

Deferral would not meet the UWMC-Northwest's Objectives.

UPDATES SUBSEQUENT TO ISSUANCE OF THE DRAFT EIS

CHAPTER 3

UPDATES SUBSEQUENT TO ISSUANCE OF THE DRAFT EIS

This chapter of the *2024 UWMC-Northwest MIMP Update* Final EIS (Final EIS) describes updates to the *2024 MIMP Update* and EIS made subsequent to issuance of the September 5, 2023 Draft EIS. The updates to this EIS made subsequent to issuance of the Draft EIS are organized by Chapters/Sections presented in the Draft EIS.

Updates to Chapter 2 – Description of Proposed Actions and Alternatives

Additional information regarding the proposed campus loop road as provided below (*see Chapter 2 of this Final EIS*).

A campus loop road is proposed to ensure safe, clear campus circulation. The proposed loop road, which would be developed in phases with adjacent building development, may be located within perimeter building setback areas. If located within perimeter building setback areas, the roadway would be located a minimum of 20 feet from property edges abutting residential uses, and substantial vegetated screening would be provided. The posted speed-limit for non-emergency vehicles would be 15 miles per hour or lower.

An additional EIS Alternative (Alternative 3) is provided (*see Chapter 2 of this Final EIS for details*)

Based on analysis conducted for the Draft EIS, and on comments received from the public and agencies on the Draft *2024 MIMP Update* and Draft EIS, an additional EIS Alternative (Alternative 3) has been identified for this Final EIS. Alternative 3 is considered the Preferred Alternative.

Updates to Chapter 3 – Affected Environment, Significant Impacts, Mitigation Measures, and Significant Unavoidable Adverse Impacts

Additional environmental analysis and mitigation (if any) for the elements of the environment analyzed in the Draft EIS follows.

3.1 Land Use/Relationship to Plans and Policies

Alternatives 1 and 2

A campus loop road is proposed to be developed in phases with adjacent development and may be located within perimeter building setback areas. The loop road would be required to be located at least 20 feet from property edges abutting residential neighbors (measured from the nearest back of curb), with substantial vegetation screening provided between the loop road and abutting residential properties. Non-emergent vehicular circulation on-campus would be limited to posted 15 miles per hour or lower.

The alignment of the proposed loop road is not defined under the Draft *2024 MIMP Update*, although the loop road could be located within the perimeter building setback area which would include the potential for increased levels of noise, light and air emissions in proximity to residential uses. Given the proposed low posted speeds, typical time of day use, distance between the road and adjacent residential uses, and substantial vegetative screening, significant adverse impacts associated with the loop road are not anticipated.

Additional parking may be provided as an expansion of the existing parking structure and/or as a standalone structure, although a specific location for additional parking is not defined neighboring under the *2024 MIMP Update*. To the extent that a new parking structure is located in proximity to residential uses, there would be the potential for increased levels of noise, air emissions, and light in proximity to residential uses. To minimize the potential for impacts to adjacent residential properties, the *2024 MIMP Update* includes Design Guidance to “*design screening on or in close proximity to parking structures facing residential neighbors to minimize visibility to/from neighboring properties and enhance building aesthetics*” and Development Standards for vegetation and screening in building setbacks.

Alternative 3 – Preferred Alternative

Introduction – As under Alternative 1 and 2, land uses under Alternative 3 on the UWMC-Northwest campus are intended to provide a range of medical service uses similar to those currently on campus, and development assumed under Alternative 3 would not represent a change in the types of land uses or land use pattern on campus. Land use impacts under Alternative 3 would be equal to or less than those anticipated under Alternatives 1 and 2.

As under Alternatives 1 and 2, Alternative 3 would accommodate approximately 862,000 sq. ft. of net new building space and up to 162 of the new licensed hospital beds under the proposed *2024 MIMP Update*. Depending on where development would occur, up to

301,000 sq. ft. of existing building space could be demolished, the same as Alternatives 1 and 2.

As under Alternatives 1 and 2, depending on the specifics of individual projects, it is anticipated that under Alternative 3 the amount of pervious surface on the campus (building footprint, paved driveway and sidewalks, paved plaza, etc.) would range from approximately 23.36 acres to 23.99 acres, with pervious area (landscaped and natural area) ranging from approximately 8.87 to 9.5 acres.

Building Heights and Densities - Alternative 3 assumes changes to the building height overlays and perimeter building setbacks from those under the existing 1991 MIMP. Compared to Alternative 1 and 2, Alternative 3 assumes additional layering of building height overlays at the campus perimeter in proximity to adjacent residential neighborhoods with extension of the 65-foot building height overlay to campus edges, and establishment of an additional mid-range building height overlay (145-foot overlay) in the north-central portion of campus in the vicinity of residential uses. The 175-foot building height overlay would be limited to the central portion of campus, with the 105-foot building height overlay along the south campus boundary adjacent to N. 115th Street and adjacent to the cemetery to the west.

Alternative 3 also includes wider perimeter building setbacks adjacent to residential areas than under Alternative 2, and more area in the widest perimeter building setback adjacent to residential areas than under Alternative 1, as described below (see Figure 2-7 in Chapter 2 of this Final EIS).

- Western Campus Edge – A 40-foot-wide perimeter building setback area assumed adjacent to residential area (Stendall Place) compared to 40-foot-wide under Alternative 1, and 30-foot-wide under Alternative 2 (a 30-foot-wide setback is included in the existing 1991 MIMP). The western boundary of campus adjacent to the cemetery also assumes a 40-foot wide perimeter building setback area.
- Southern Campus Edge – Compared to the 30-foot-wide perimeter building setback area under Alternative 1 and 20-foot perimeter building setback under Alternative 2, Alternative 3 assumes a 20-foot-wide perimeter building setback area along N 115th Street (a 30-foot-wide setback is included in the existing 1991 MIMP).
- Northern Campus Edge – Compared to the 30-foot-wide perimeter building setback area under Alternative 1 and 20-foot wide perimeter building setback under Alternative 2, Alternative 3 assumes a 40-foot-wide perimeter building setback area along N 120th Street (a 120-foot-wide setback is included in the existing 1991 MIMP).

- Eastern Campus Edge – Compared to the 30-/40-foot-wide perimeter building setback assumed under Alternative 1 and 20-/30-foot wide perimeter building setback under Alternative 2, Alternative 3 assumes a 40-foot-wide perimeter building setback area along the entire eastern campus boundary (180-, 120-, and 40-foot-wide setbacks are included in the existing 1991 MIMP).

As under Alternatives 1 and 2, development under Alternative 3 would be consistent with the proposed *2024 MIMP Update* and would provide approximately 862,000 sq. ft. of net new building space to address regional health care needs; in combination with existing buildings, the campus would contain up to 1.6 million sq. ft. of building space. As under Alternatives 1 and 2, the amount of building space and density on campus would approximately double under Alternative 3.

Because the building development envelope established by the assumed building height overlays and perimeter building setbacks under Alternative 3 would be smaller than under Alternatives 1 and 2 due to the reduction in area in building height overlay with the tallest 175-foot building height, the 1.6 million sq. ft. of total building space would be anticipated to slightly increase the percentage of development envelope from the approximately 14 percent of the development envelope under Alternative 2 and approximately 12 percent under Alternative 1.

As under Alternatives 1 and 2, additional parking may be provided as an expansion of the existing parking structure and/or as a standalone structure, although a specific location for additional parking is not defined under the *2024 MIMP Update*. To the extent that a new parking structure is located in proximity to residential uses, there would be the potential for increased levels of noise, air emissions, and light in proximity to residential uses. To minimize the potential for impacts to adjacent residential properties, the *2024 MIMP Update* includes Design Guidance to “*design screening on or in close proximity to parking structures facing residential neighbors to minimize visibility to/from neighboring properties and enhance building aesthetics*” and Development Standards for vegetation and screening in building setbacks.

As under Alternatives 1 and 2, intensification in land uses on the UWMC-Northwest campus would occur as result of increased density and building heights under Alternative 3. With proposed mitigation measures, significant adverse unavoidable land use impacts under Alternative 3 are not anticipated.

3.2 Air Quality/GHG Emissions

Alternative 3 – Preferred Alternative

Similar to Alternatives 1 and 2 and consistent with the proposed *2024 MIMP Update*, approximately 862,000 sq. ft. of net new building space would be developed throughout the campus under Alternative 3. The primary difference between Alternatives 1 and 2 under Alternative 3 is that Alternative 3 assumes additional restrictions on building heights (tallest buildings limited to the central portion of campus), and additional perimeter building setback area.

Construction - Development under Alternative 3 would result in similar construction-related air quality impacts as those described for Alternatives 1 and 2. Construction activities would result in localized short-term increases in particulates (dust), equipment emissions (carbon monoxide) and potential odors in the vicinity of construction sites. The provision of wider perimeter setbacks than under Alternative 2 could mean that construction activity may be located farther from adjacent properties under Alternative 3; construction activity under Alternative 3 would likely be located a similar distance from adjacent properties than under Alternative 1. Periodic traffic delays and construction-related traffic could also contribute to vehicle emissions during construction. With implementation of the controls required for the various aspects of construction activities and consistent use of BMPs to minimize emissions, construction under Alternative 3 would not be expected to significantly affect air quality.

Operation - Similar to Alternatives 1 and 2, overall campus development and population growth would increase the consumption of electricity, fossil fuels and natural gas which would contribute to cumulative air quality impacts. Emissions would be subject to applicable requirements of the University of Washington and the Puget Sound Clean Air Agency.

GHG Emissions - Alternative 3 assumes the same amount of building development as Alternatives 1 and 2 (approximately 862,000 sq. ft. of net new building space) and GHG emissions associated with development under the proposed *2024 MIMP Update* would also be the same (approximately 2,205,514 MTCO_{2e} lifespan emissions or 35,288 MTCO_{2e} annual emissions).

Indirect - Alternatives 1 and 2 included a potential new driveway access from N 120th Street which would introduce new levels of vehicular traffic in the area to the north of campus and would result in associated vehicular emissions which could be noticeable for residences in this area. Alternative 3 does not include the optional access from N 120th Street and the potential for indirect air quality impacts under Alternative 3 would be less than under Alternatives 1 and 2.

3.3 Environmental Health

Alternative 3 – Preferred Alternative

Hazardous Materials – Construction – As under Alternatives 1 and 2, during the construction process, gasoline and other petroleum-based products would be used for the operation of construction vehicles and equipment under Alternative 3. Such products would be handled and stored in accordance with applicable standards and regulations. As with any construction activity, accidental spills of hazardous materials from equipment or vehicles could occur; however, a spill prevention plan would minimize the potential of an accidental release of hazardous materials into the environment.

Hazardous Materials – Operation – As under Alternatives 1 and 2, new development under Alternative 3 would include hospital and medical office uses and an associated increase in the use and generation of hazardous materials/chemicals and hazardous waste would be anticipated. It is assumed that new development would utilize and generate similar types of hazardous materials as described above under Affected Environment, but at higher volumes. However, risks to human health would not be anticipated to increase significantly with development as UW Medicine would continue to manage hazardous materials on campus in accordance with existing policies/standards established by the University's Environmental Health and Safety Department, as well as applicable local, state and federal standards/regulations/laws.

Noise - Potential noise impacts associated with Alternative 3 would be similar to those identified for Alternatives 1 and 2 and would primarily occur during the construction of individual development projects under the proposed *2024 MIMP Update*. Depending on the location of construction activity, construction noise would result in temporary annoyance and possible increased speech interference near potential development areas. Such noise could impact existing on-campus uses (e.g., hospital, patient rooms, etc.) and disturb residential uses that are in the vicinity of potential development sites.

Operational noise associated with development under Alternative 3 would primarily be related to building operational systems (e.g., mechanical systems, etc.) and traffic noise (including noise associated with loop road and parking facilities). Increased traffic volumes from new development would result in an increase in traffic-related noise on-campus and on surrounding roadways. However, the campus and surrounding area is a highly developed urban area with existing traffic-related noise and the increase in traffic volumes associated with the proposed *2024 MIMP Update* is not anticipated to result in significant noise impacts.

As under Alternatives 1 and 2, Alternative 3 includes a Central Utility Plant (CUP) intended to consolidate and separate Medical Center infrastructure to an enclosed standalone facility. The CUP would both provide needed power redundancy for existing buildings and required power for future buildings. It would also allow UWMC-Northwest to replace the numerous individual systems associated with existing buildings on campus; the majority of the existing equipment is not enclosed.

As under current conditions and under Alternatives 1 and 2, the highest noise generating pieces of equipment under Alternative 3 are anticipated to be heat pumps and emergency generators. The proposed CUP(s) would enclose equipment within a structure, which would allow for greater control of noise compared to current conditions.

Emergency generators require air intakes/exhaust which would allow for some noise to escape the enclosed structure. However, because emergency generators are only utilized in the case of power disruption or during required monthly testing (typically one hour of testing per month), the amount of time the emergency generators would be utilized is anticipated to be low and would be similar to current conditions. Sound attenuation measures would be identified during CUP design and implementation of the University design and environmental review process.

Indirect - Alternatives 1 and 2 included a potential new driveway access from N 120th Street which would introduce new levels of vehicular traffic and associated noise in the area to the north of campus. Alternative 3 does not include the optional access from N 120th Street and the potential for indirect noise impacts under Alternative 3 would be less than under Alternatives 1 and 2.

3.4 Aesthetics/Light & Glare/Shadows

Alternative 3 – Preferred Alternative

Aesthetics - Consistent with the 2024 MIMP Update and Alternatives 1 and 2, Alternative 3 assumes that the maximum building heights allowed would increase from the existing 1991 MIMP. The proposed height increase would differ from those assumed under Alternatives 1 and 2. Compared to Alternative 1 and 2, Alternative 3 assumes additional layering of building height overlays at the campus perimeter in proximity to adjacent residential neighborhoods with extension of the 65-foot building height overlay to the northern and portions of the western/eastern campus edges, and establishment of an additional mid-range building height overlay (145-foot overlay) in the north-central portion of campus in the vicinity of residential uses. The 175-foot building height overlay would be limited to the central portion of campus, with the 105-foot building height overlay along the south campus boundary adjacent to N 115th Street and adjacent to the cemetery to the west.

Similar to Alternatives 1 and 2, Alternative 3 allows for buildings that are taller than existing buildings on the UWMC-Northwest campus. However, given the reduced portion of the campus in the 175-foot building height overlay, the potential for views of taller buildings would be less than under Alternatives 1 and 2. The overall character of views from the various viewpoints under Alternative 3 would be similar to those under Alternatives 1 and 2 although the amount of building area visible could be less, depending on the viewpoint.

Because Alternative 3 does not include the optional driveway access from N. 120th Street, visual impacts associated with this new driveway to the area north of the campus identified under Alternatives 1 and 2 would not occur under Alternative 3.

For this Final EIS, visual massing simulations were prepared for Alternative 3 based on photographs of the campus from Draft EIS viewpoints 4 and 5, with simulations of potential development under Alternative 3 from these viewpoints as follows.

Viewpoint 4 – Densmore Ave N

Alternative 3 assumes a 65-foot building height overlay along N 120th Street with a 145-foot building height overlay set farther back; this is compared to a 175-foot building height overlay along N 120th Street under Alternative 1, and a 65-foot building height overlay along N 120th Street with a 175-foot building height overlay set farther back under Alternative 2. As illustrated in **Figure 3-1**, building massing scenarios would be similar to those under Alternatives 1 and 2, although the 175-foot building height overlay that is visible under Alternatives 1 and 2 would not be visible under Alternative 3 from this viewpoint. The view of clearing of existing trees and increased ability to view building development in the center of campus associated with the optional new access from N 120th Street under Alternative 1 and Alternative 2 would not occur under Alternative 3.

Viewpoint 5 – Ashworth Ave N

Alternative 3 assumes a 65-foot building height overlay along the west campus edge with a 145-foot building height overlay set farther back; this is compared to a 65-foot building height along the west campus edge with a 175-foot building height overlay set farther back under Alternatives 1 and 2. As illustrated in **Figure 3-2**, building massing scenarios would be generally similar to Alternative 1 and 2, although the 175-foot building height overlay visible under Alternatives 1 and 2 would be replaced with a lower 145-foot building height overlay under Alternative 3.

UWMC-Northwest 2024 Major Institution Master Plan Update
Final EIS

Existing Condition



UWMC - Northwest View Analysis | Alternative 3 - Scenario 1



65' height overlay @ 40' setback from property line; 145' height overlay @ 130' from property line; @ 170' from camera
Potential new construction almost 800' from camera



UWMC - Northwest View Analysis | Alternative 3 - Scenario 2



65' height overlay @ 40' setback from property line; 145' height overlay @ 130' from property line; @ 170' from camera
Potential new construction almost 350' from camera

UWMC - Northwest View Analysis | Alternative 3 - Scenario 3



65' height overlay @ 40' setback from property line; 145' height overlay @ 130' from property line; @ 170' from camera
Potential new construction almost 360' from camera

UWMC - Northwest View Analysis | Alternative 3 - Scenario 4



65' height overlay @ 40' setback from property line; 145' height overlay @ 130' from property line; @ 170' from camera
Potential new construction almost 300' from camera

Source: NBBJ, 2023.

Figure 3-1

Alternative 3: Viewpoint 4—Densmore Ave N (Looking South)

**UWMC-Northwest 2024 Major Institution Master Plan Update
Final EIS**

Existing Condition



UWMC - Northwest View Analysis | Alternative 3 - Scenario 1



65' height overlay @ 40' setback from property line; @ 60' east from camera
145' height overlay @ 140' east from camera (approx. 160' east from property line)
Potential new construction almost 110' south from camera



UWMC - Northwest View Analysis | Alternative 3 - Scenario 2



65' height overlay @ 40' setback from property line; @ 60' east from camera
145' height overlay @ 140' east from camera (approx. 160' east from property line)
Potential new construction almost 300' south from camera

UWMC - Northwest View Analysis | Alternative 3 - Scenario 3

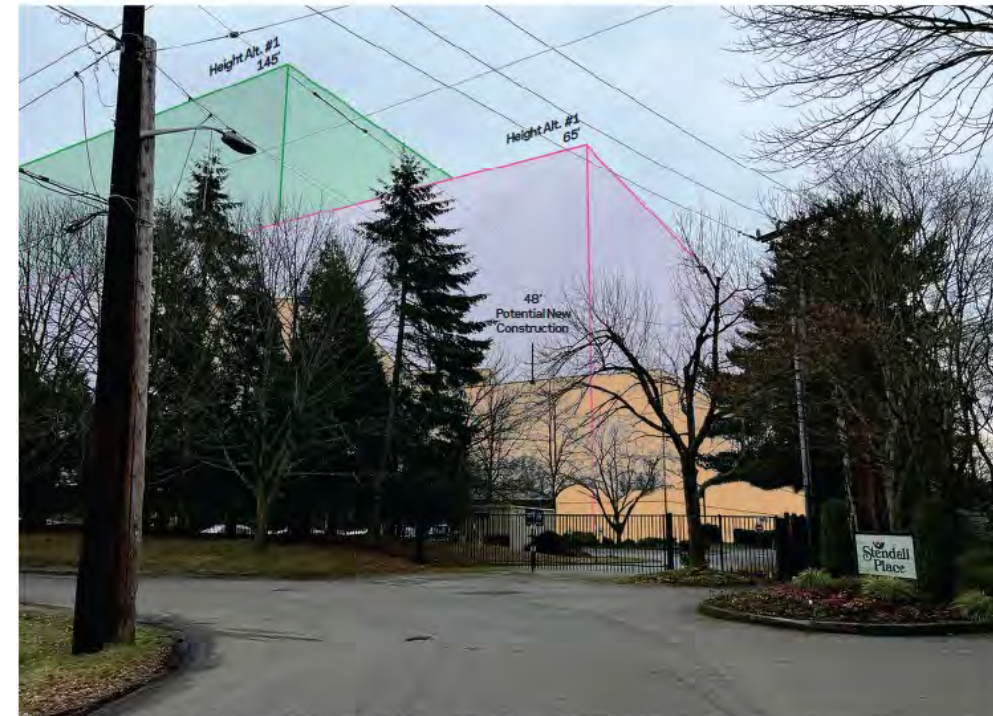

65' height overlay @ 40' setback from property line; @ 60' east from camera
145' height overlay @ 140' east from camera (approx. 160' east from property line)
Potential new construction almost 210' south from camera

UWMC - Northwest View Analysis | Alternative 3 - Scenario 4



65' height overlay @ 40' setback from property line; @ 60' east from camera
145' height overlay @ 140' east from camera (approx. 160' east from property line)
Potential new construction almost 260' south from camera

Source: NBBJ, 2023.

Figure 3-2

Alternative 3: Viewpoint 5—Ashworth Ave N (Looking Southeast)

Light & Glare - Light and glare conditions under Alternative 3 would be similar to those described for Alternatives 1 and 2, and light and glare impacts with development under Alternative 3 anticipated to be low.

Because Alternative 3 does not include the optional driveway access from N. 120th Street, potential vehicle light impacts associated with this new driveway to the area north of the campus identified under Alternatives 1 and 2 would not occur under Alternative 3.

Shadows - Shadows under Alternative 3 would be cast in similar directions and area as under Alternatives 1 and 2, with shadow conditions generally similar to or less than under Alternatives 1 or 2, with level of potential shadow cast somewhat lower in the northern portion of campus due to lower building height limits.

3.5 Historic & Cultural Resources

Alternative 3 – Preferred Alternative

Historic Resources - There are no existing buildings on or adjacent to the campus that are currently listed on the NRHP or as a City of Seattle Landmark and as such, no direct or indirect impacts to listed historic resources would be anticipated with development under the proposed EIS Alternatives (including Alternative 3).

As under Alternatives 1 and 2, project-specific actions under Alternative 3 that would affect buildings would include a project-specific historic resources review to determine potential impacts and mitigation measures, if necessary. To further ensure that historic resources are considered, the University would prepare an Historic Resources Addendum (HRA) for any project that makes exterior alterations to a building that is over 50 years of age or is located adjacent to campus buildings or features over 50 years of age. Significant impacts to historic resources under Alternative 3 are not anticipated.

Cultural Resources – As under Alternative 1 and 2, development under Alternative 3 could impact cultural resources if any are present within the campus area. However, according to the WISAARD Predictive Model, the entire campus area is considered a moderately low risk (the second lowest predictive designation available under the model) for archaeological resources. Cultural resources surveys are not recommended under this designation but can be performed contingent upon project parameters. In addition, the existing campus area is already highly developed (approximately 62 percent of the site is in impervious surfaces) from prior building and infrastructure projects on the campus and as such, it is likely that prior development of the campus has already disturbed and/or removed native soils that were previously on the site. As such, the likelihood for cultural resource impacts from development under Alternative 3 is anticipated to be low.

3.6 Transportation

Transportation analysis information added or changed subsequent to issuance of the Draft EIS is provided below and shaded to ease identification of the added or changed information. The complete Transportation Discipline Report (TDR) is provided in **Appendix B** to this Final EIS.

Affected Environment

Trip Generation - Vehicle trip generation for the campus was defined based on weekday AM and PM peak hour counts collected over a two-day period at the access points as well as observations of on-street parking along the campus N 115th Street frontage. Average traffic counts for the AM and PM peak hour period totaled 606 trips and 516 trips, respectively. Based on the current square footage of the campus, this translates to a weekday AM peak hour rate of 1.10 trips/1,000 gsf and a PM peak hour trip rate of 0.94 trips/1,000 gsf.

Person trips were also estimated for the campus based on the observed vehicle trip generation and results from the UWMC – Northwest Commute Trip Reduction (CTR) survey last conducted in 2019. Although the survey is conducted for campus employees, the results were applied to the broader campus community. The results of the 2019 CTR survey showed an overall non-vehicle mode split of 11 percent.

Transit Service - LINK light rail Northgate Station, operated by Sound Transit, provides connections to regional transit routes operated by King County Metro and Snohomish County. Northgate Station is located approximately 1 mile from the campus. Note that Routes 345 and 346 with stops in close proximity to the campus provide service to the Northgate Link Station.

Non-Motorized Facilities - As noted previously sidewalks are provided along arterial streets in the vicinity of the site inclusive of connections to all transit routes located within the vicinity of the site. Bike lanes are provided along Meridian Avenue N, proximate to the campus. Based on the results of the 2019 CTR survey, pedestrian and bicycle mode splits for employees was 3 percent.

Traffic Safety - Recent collision records were reviewed within the study area to identify existing traffic safety issues at the study intersections and along the project site frontage. The most recent three-year summary of accident data from the Seattle Department of Transportation (SDOT) is for the period between January 1, 2019 and December 31, 2021.

SDOT defines High Collision Locations (HCL) as signalized intersections with an average of 10 or more collisions, unsignalized intersections with an average of 5 or more collisions, mid-

block locations with an average of 10 or more collisions, and locations with 5 or more pedestrian or bicycle collisions in the previous three years. Intersections designated as high accident locations are targeted for future safety improvements in an effort to reduce the occurrence of accidents. Based on the collision history at the study area intersections, there are no intersections during the review period that meet the HCL criteria as defined by the City of Seattle.

The study intersections had an annual average of approximately 8 collisions or fewer reported per year. Note that the majority of collisions resulted in property damage throughout the study area and there were one reported fatality. Additionally, there were 1 to 4 reported collisions involving a pedestrian or bicyclist that occurred at 8 of the study intersections including Meridian Avenue N, Corliss Avenue N and 1st Avenue N along N Northgate Way and at Aurora Avenue N and Meridian Avenue N along N 115th Street as well as the eastern site access. The existing safety concerns along Aurora Avenue N are known and there are planned improvements along the Aurora Avenue North corridor to address safety and mobility issues, which are described in the No Action section.

No Action Alternative

Street System - N 130th Street Vision Zero Safety Corridor - The cross section at N 130th Street currently has four driving lanes with a sidewalk on each side of the road and will be modified into two through-lanes between Stone Avenue N and 1st Avenue NE with bike lanes and a center two-way left turn lane. Speed limits will also be reduced to 25 mph along the corridor as well as restricting right-turns on red (RTOR). Future extension of the channelization modifications are also a potential which could extend between Linden Avenue N and 5th Avenue NE. The channelization modifications, bike lanes, and speed limit reductions between Stone Avenue N and 1st Avenue NE along N 130th Street are planned to be completed in 2023 and are funded as part of the Vision Zero program. This project results in assumed channelization modifications to the west leg of the 1st Avenue NE/N 130th Street intersection included in the No Action analyses.

Alternative 3 – Preferred Alternative

Transportation impacts under Alternative 3 would be similar to those described for Alternative 1 as there are no changes in development totals or development type. As identified in Alternatives 1 and 2, a 3rd access point to the campus is proposed. The proposed access under Alternative 3 is via N 115th Street.

Mitigation Measures

The **Meridian Avenue N/N 115th Street** all-way stop controlled intersection is forecast to degrade from operating at LOS D and E during the AM and PM peak hour No Action 2030

and 2040 conditions, to operate at LOS F during the AM and PM peak hour Alternative 1 2030 and 2040 conditions. This increase in delay at the all-way stop controlled intersection is identified as a significant impact which will require mitigation. As the current intersection is currently operating as an all-way stop, the proposed mitigation includes the signalization of the intersection.¹ No changes in channelization are proposed with the signalization of the intersection. The timing of this improvement is based on the amount of development occurring and the horizon year that the development is anticipated due to background traffic growth. The following highlights mitigation triggers for this improvement numbers reflect net new square footage to campus. Implementation of a future improvement at this intersection is subject to SDOT approval at the time of the development trigger.

- 2026 – up to 180,000 gsf
- 2027 – up to 170,000 gsf
- 2028 – up to 155,000 gsf
- 2029 – up to 140,000 gsf
- 2030 – up to 125,000 gsf
- 2031 – up to 110,000 gsf
- 2032 – up to 95,000 gsf
- 2033 – up to 80,000 gsf
- 2034 – up to 60,000 gsf
- 2035 – up to 45,000 gsf

Significant Unavoidable Adverse Impacts

The LOS at the **1st Avenue NE/N 130th Street** intersection is forecast to degrade from operating at LOS D under future (2040) No Action weekday PM peak hour conditions to LOS E with Alternative 1, with an increase in delay of approximately 7 seconds. This exceeds the typical threshold of 5 seconds for identifying significant impacts. The reduced operations are associated with the proposed channelization revision along the N 130th Street corridor as part of the Vision Zero safety corridor project which prioritizes the implementation of non-motorized facilities including installing bicycle lanes along both sides of the road. This is accomplished by reducing N 130th Street from 4 vehicular lanes to a three-lane road (two through-lanes with a center two-way left turn lane) west of 1st Avenue NE and restricting right-turns on red. Given the planned improvement at this location to reduce the vehicular capacity, prioritizing non-motorized, an improvement to increase vehicular capacity at this location is not proposed.

Non-Motorized Connectivity Improvements

To improve connectivity to the transit stops located along Meridian Avenue N at N 120th Street, UWMC-Northwest will construct curb, gutter, and sidewalk along the south side of N 120th Street between Meridian Avenue N and west to the existing improved section. The

¹ Note that a roundabout (limited to a compact roundabout due to right-of-way constraints) was reviewed as an alternative mitigation option to a traffic signal but determined not feasible due to both a bus and ambulance needing to drive over/through the center of the compact roundabout to make a northbound left-turn to access the campus.

section to be constructed is anticipated to generally match what was constructed along the UWMC northern frontage. Final plans and construction of the planned improvements are dependent upon future SDOT approval. These improvements would be triggered in the future when the hospital increases the patient occupiable area by greater than 250,000 net new gsf; resulting in increases in patient volume and increased trip volume (i.e. size excludes the central utility plant and parking).

3.7 Utilities

Alternative 3 – Preferred Alternative

Water – Assumed development under Alternative 3 would result in increased demands on the water supply and distribution system similar to that under Alternative 1 and 2. As development occurs under Alternative 3 specific development projects would require new connections to the existing water system and associated project-specific analysis to determine the requirements to provide water service to each project. Significant impacts to the water system are not anticipated.

Sewer – As under Alternative 1 and 2, development under Alternative 3 would result in greater demands on the sewer systems that serve the UWMC-Northwest campus. It is anticipated that new development would connect to the current sanitary sewer systems within the UWMC-Northwest campus and ultimately Seattle Public Utilities. Any new connections for specific development projects to the onsite side sewers or new connections to the adjacent sewer mains would need to have a side sewer evaluation completed to verify that the system and services have the capacity to serve new development projects. Significant impacts to the sewer system are not anticipated.

Stormwater - Stormwater runoff is directly related to the amount of impervious surfaces in a given area and new development under Alternative 3 would result in an overall increase in impervious surfaces associated with new buildings and other impervious surfaces (walkways, driveways, etc.) similar to that under Alternatives 1 and 2. As specific development projects occur under the proposed *2024 MIMP Update*, each project would be required to meet the applicable requirements of the City of Seattle’s Stormwater Manual (COSSM). Significant impacts to the stormwater system are not anticipated.

3.8 Construction Impacts

Subsequent to issuance of the Draft EIS, City of Seattle Municipal Code (SMC) 25.11 – Tree Protection was amended. Updated discussion in this section associated with tree protection is shaded to ease identification of the added or changed information. Note that all discussion related to Alternative 3 (Preferred Alternative) is new but is not shaded.

Alternatives 1 and 2

Trees: Affected Environment - The UWMC-Northwest campus currently contains approximately 12 acres of landscape and lawn areas dispersed across campus, including mature evergreen and deciduous trees. An intentionally designed buffer along the perimeter of the campus has a mixture of native and non-native species of trees, bushes, and ground cover.

The campus currently contains approximately 597 trees. Tree species on campus include but are not limited to: red oak (*Quercus rubra*), western red cedar (*Thuja plicata*), cherry plum (*Prunus cerasifera*), Douglas fir (*Pseudotsuga menziesii*), lodgepole pine (*Pinus contorta*), Japanese maple (*Acer palmatum*), paper birch (*Betula papyrifera*), river birch (*Betula nigra*), Hinoki cypress (*Chamaecyparis obtuse*), Katsura tree (*Cercidiphyllum japonicum*), southern magnolia (*Magnolia grandiflora*), and Leyland cypress (*X Cuprocyparis leylandii*).

City of Seattle Municipal Code (SMC) 25.11 – Tree Protection, is intended to, among other things, *to preserve and enhance the City’s physical and aesthetic character by preventing untimely and indiscriminate removal or destruction of trees*. SMC 25.11 includes categories of regulated trees, including: **Tier 1** – designated heritage trees; and, **Tier 2** – trees 24 inches at DSH² or greater, tree groves, and specific tree species as provided in the Director’s Rule. SMC 25.11 indicates that Tier 2 trees located within a Major Institution Overlay District may be removed if development is under an approved MIMP, planned development cannot occur without removal of the tree(s), and mitigation is provided.

Of the approximately 597 trees on the UWMC-Northwest campus, approximately 94 were determined by a certified arborist to meet the City of Seattle definition of Tier 2 tree. No Tier 1 trees are identified on the UWMC-Northwest campus.

Trees: Impacts - Under Alternative 1 approximately 293 of the approximately 597 trees on campus are located with the proposed perimeter setback area, including approximately 20 Tier 2 trees. Under Alternative 2 approximately 237 trees are located within the proposed perimeter setback area, including approximately 18 Tier 2 trees. It is assumed that the majority of the existing trees located within the perimeter building setback areas would be retained under the Draft 2024 MIMP Update. Any applicable Tier 2 tree removed with development under the Draft 2024 MIMP Update would be replaced consistent with City of Seattle requirements (SMC 25.11).

Although any tree outside of the proposed perimeter building setback areas could potentially be removed under the Draft 2024 MIMP Update, it is considered unlikely that existing trees in proximity to buildings anticipated to be retained under the Draft 2024

² Diameter at standard height – 4.5 feet above ground.

MIMP Update would be removed, including trees in the vicinity of the Parking Garage, McMurray Office Building, Fred Hutch Cancer Center Building, and the Medical Office Building.

The Draft *2024 MIMP Update* intends to identify and maintain open spaces throughout the campus that will be connected and accessible. A detailed Urban Forestry Management Plan is being developed for the campus that will document existing trees and provide standards for preservation and enhancement of trees on campus.

Alternative 3 – Preferred Alternative

Earth - The potential for individual projects under Alternative 3 to encounter earth conditions associated with liquefaction (sudden loss of soil strength due to earthquake) is considered low, and no portion of the site is identified by the City of Seattle as Liquefaction Area. However, any proposed development on the campus under the *2024 MIMP Update* would be required to prepare soils engineering studies consistent with SMC 25.09.100 to confirm liquefaction potential.

Air Quality – As under Alternatives 1 and 2, development of approximately 862,000 sq. ft. of net new building space on the campus under Alternative 3 would result in localized short-term increases in particulates (dust) and equipment emissions (carbon monoxide) in the vicinity of construction sites. Key construction activities causing potential impacts include: removal of existing pavement and/or buildings, excavation, grading, stockpiling of soils, soil compaction, and operation of diesel-powered trucks and equipment (i.e., generators and compressors) on the individual potential development sites.

Demolition of existing structures would require the removal and disposal of building materials, some of which could contain asbestos. If this proves to be the case, demolition contractors would be required to comply with EPA and PSCAA regulations related to the safe removal and disposal of any asbestos-containing materials.

Construction under Alternative would require the use of heavy trucks, excavators, graders, cranes, pile drivers, and a range of smaller equipment such as generators, pumps, and compressors. During construction, on-campus activity and periodic traffic delays on adjacent streets could also contribute to slightly greater vehicle emissions. Emissions from existing transportation sources (primarily vehicular traffic) around the development areas would very likely outweigh any emissions resulting from construction equipment.

With implementation of the controls required for the various aspects of construction activities and consistent use of best management practices (BMPs) to minimize emissions,

construction activities under Alternative 3 would not be expected to significantly affect air quality.

Noise – As under Alternative 1 and 2, construction under Alternative 3 would generate noise that would result in temporary annoyance and possibly increased speech interference near the individual construction sites. These impacts would temporarily affect adjacent uses in the campus vicinity, particularly where individual construction sites are in proximity to the campus edges and adjacent to residential uses to the west, north and east (N 120th St would provide some additional separation between individual construction projects and residential uses to the north). Construction activities associated with individual projects could also affect visitors to cemeteries to the west and south of campus (N 115th St would provide some additional separation between individual construction projects and cemetery use to the south). In addition, construction associated with individual projects under the *2024 MIMP Update* could also affect existing health care uses on campus that are sensitive to construction-related noise, depending on the location of the individual project. To minimize the potential for construction activities to interfere with residential, health care, cemetery and other on and adjacent to the UWMC-Northwest campus, measures such as limiting the use of higher noise equipment, ensuring properly sized/maintained mufflers and other silencers, and limiting the hours of construction would be implemented (refer to Chapter 1 of this Final EIS for a listing of identified construction mitigation measures).

Trees – Approximately 293 trees are located within the proposed perimeter building setback area under Alternative 3, including approximately 20 Tier 2 trees. As under Alternatives 1 and 2, it is assumed that the majority of the existing trees located within the perimeter building setback areas would be retained under Alternative 3. Because of the wider perimeter building setback area provided under Alternative 3, impacts to Tier 2 trees would be similar to or less than that under Alternatives 1 and 2. Any applicable Tier 2 tree removed with development under the *2024 MIMP Update* would be replaced consistent with City of Seattle requirements (SMC 25.11).

Although any tree outside of the proposed perimeter building setback areas could potentially be removed under the *2024 MIMP Update*, it is considered unlikely that existing trees in proximity to buildings anticipated to be retained under the *2024 MIMP Update* would be removed, including trees in the vicinity of the Parking Garage, McMurray Office Building, Fred Hutch Cancer Center Building, and the Medical Office Building.

The *2024 MIMP Update* intends to identify and maintain open spaces throughout the campus that will be connected and accessible. A detailed Urban Forestry Management Plan is being developed for the campus that will document existing trees and provide standards for preservation and enhancement of trees on campus.

COMMENT RECEIVED ON THE DRAFT EIS AND RESPONSES

CHAPTER 4 COMMENT LETTERS AND RESPONSES

This chapter of the *2024 UWMC-Northwest MIMP Update* Final EIS (Final EIS) contains comments received on the Draft *2024 UWMC-Northwest MIMP Update* (Draft *2024 MIMP Update*) and Draft EIS, and provides responses to the comments. Fifty-five letters and emails with comments regarding the Draft *2024 MIMP Update* and Draft EIS, and the analysis of environmental impacts were received during the public comment period on the Draft *2024 MIMP Update* and Draft EIS. Each letter is included in this section of the Final EIS. Comment letters/numbers appear in the margins of the letters commentary and are cross-referenced to the corresponding responses. Responses are provided directly after each letter/email commentary.

Draft EIS /Draft 2024 MIMP Update Comment Letters

Letter 1 - SDCI	Letter 28 - Lewis
Letter 2 - SDOT	Letter 29 - MacDougall
Letter 3 - DESC	Letter 30 - Mangiaracina
Letter 4 - SEIU & Nurses	Letter 31 - Matson
Letter 5 - Stendall Place	Letter 32 - Mayes
Letter 5a - UWMC-NW DAC	Letter 33 - McElmeel
Letter 6 - Anther	Letter 34 - McNaughton
Letter 7 - Arora	Letter 35 - Michalenko
Letter 8 - Baskey	Letter 36 - Mohr
Letter 9 - Bell	Letter 37 - Moore
Letter 10 - Bjork	Letter 38 - O'Grady 1
Letter 11 - Blomberg	Letter 39 - O'Grady 2
Letter 12 - Breen	Letter 40 - Poyer
Letter 13 - Chastain	Letter 41 - Roesijadi
Letter 14 - Dhoot	Letter 42 - Ross
Letter 15 -Donohue	Letter 43 - Rosson
Letter 16 - Drechsler	Letter 44 - Saunders
Letter 17 - Edwards	Letter 45 - Schollmeyer
Letter 18 - Feiling	Letter 46 - Scholten
Letter 19 - Follis	Letter 47 - Sevareid
Letter 20 - Forhan	Letter 48 - Silverman
Letter 21 - Garbrick	Letter 49 - Simonds
Letter 22 - Giles	Letter 50 - Smith
Letter 23 - Grine	Letter 51 - Williams
Letter 24 - Harding	Letter 52 - Woodruff
Letter 25 - Howard	Letter 53 - Yates
Letter 26 - Kouhi	Letter 54 - Anonymous
Letter 27 - Lang	



Memorandum

TO: Julie Blakeslee, University of Washington Environmental and Land Use Planner
FROM: SDCI
DATE: October 3, 2023, November 16, 2023
SUBJECT: University of Washington Medical Center - Northwest Draft Major Institution Master Plan (MIMP and Draft Environmental Impact Statement (DEIS))

Dear Julie:

Thank you for the opportunity to comment on the University of Washington Medical Center - Northwest's Draft MIMP and DEIS. SDCI has the following comments:

SDCI Land Use

Draft MIMP

SMC 23.69.030 Contents of a Master Plan. This section has a good list of items to be included in the MIMP and can be used as a checklist. Please note that it is time to start laying out possible building locations, open spaces, circulation, and parking and these items should be in the next step to show the DAC. I suggest using this code section when presenting to the DAC as an organizing feature and evidence that the code language is directing the MIMP effort, and that UW is following it.

1

Please add additional documentation to the MIMP including the following:

Component one: Development Standards. SMC 23.69.030 B, C. Please use the UW 2019 Master Plan as a guide to topics to be included.

2

SMC 23.69.030 The list of development standards to be included. Make sure that the MIMP proposal has items C 1-4 (Item 4 the Director is requiring). Please create a table noting that each component is included as part of a table of contents or for a DAC discussion.

3

Component two: Development program. SMC 23.69.030 D, E 1-13. (FYI Please note that some items of 1-13 do not apply, also please note language that some items 1-13 may require a future amendment (E4b) while others do not E 10.) Please create a table noting that each component was addressed and included for use as a table of contents or for a DAC discussion to point out the adequacy and thoroughness of the proposal.

4

Component three: Transportation Management Program. SMC 23.69.030 F. Please layout the response to items SMC 23.69.030 F 1-2 for DAC consideration etc. Please add the TMP to the MIMP. Please review the TMP with SDOT and John Shaw before the Dec 4 meeting to pick up additional comments and corrections from them and incorporating their prior comments.

5



Urban Forest Management Plan. Please submit a draft plan so our tree review experts can begin to see how it fits in the review framework. | 6

A discreet Open Space development standard appears to be missing. It is a strongly worded development program component in SMC 23.69.030E4b. The next iteration should address what the code language calls out as “significant and serves as a focal point for users of the Major Institution.” | 7

Should a podium height development standard be added? | 8

Should a signs and banners section be included? | 9

Should upper level setbacks be included anywhere? | 10

DEIS
No comments.

SDCI Transportation

Draft MIMP:

Page 68: The second bullet in the Transit section states, “Be aware of pedestrian routes that connect to transit stops as part of the transit system’s quality and level of safety”. The first bullet in the General Sustainability Guidance section states “UW Medicine actively promotes strengthened pedestrian and public transit routes to encourage alternative modes of transportation” (page 74). To support this goal, the Transit bullet should be strengthened, e.g., “Establish pedestrian routes that connect to transit stops...” | 11

Page 69: The second bullet in the Shuttle section reads, “Consider enhanced lighting, shelters, landing areas and wider sidewalks for any future campus shuttle stops where feasible”. As the internal circulation system will be substantially redesigned, it seems that it would always be feasible to consider these improvements. (Note similar language in the Rideshare section without the feasibility qualification.) | 12



Page 69 (and elsewhere): The last Rideshare bullet refers to “Transportation Management Plan”; please note that the title of City of Seattle trip reduction program is “Transportation Management Program”. | 13

Page 71: The third bullet in the Loading section refers to “truck drive visibility”; is this meant to read “truck driver visibility”? | 14

Page 139, Appendix E, Transportation Management Plan: (1) Change to “Program”; (2) More detail is required in this section. SMC 23.69.030 F2 notes that the TMP must contain, among other items, “Specific institutional programs to reduce traffic impacts and to encourage the use of public transit, carpools and other alternatives to single-occupant vehicles”. Please also note that SMC 23.54.016 C refers to a general SOV goal of “50 percent or less” for employees, staff, and students; what SOV goal is being proposed for this MIMP? | 15

DEIS:

All comments refer to Appendix E: Transportation Discipline Report.

Page 8: Trip Generation: The totals in the text don’t include on-street parking along N 115th Street; however, the rates calculated in Table 2 do include these trips. Please clarify. | 16

Page 17, Table 10: Why is the average deliveries per day not 29? | 17

Page 18, 2nd paragraph: The 26,000 square feet does not represent “approved development”; it is the outstanding balance in the current MIMP against which future development applications (if any) could draw. | 18

Page 30, Table 19: Why is the utilization increase for Route 345 so much greater than for the other routes? | 19

SDCI Zoning

Draft MIMP:

Page 52: First full paragraph: Consider including updates to landscaping, tree retention and plantings (Urban Forest Management Plan), and total bicycle and vehicle parking stalls in the annual MIMP report in addition to gross square footage. | 20

Page 81: It appears that your setbacks section refers to alternative 2 – update this section as necessary to address the final alternative/design for height and setbacks. | 21

Page 84: Will the MIMP require any electric vehicle charging infrastructure for new parking provided on site or will the plan defer to standards in SMC 23.54.030.L for EV-ready parking? | 22



Page 89: Please clarify if signs are allowed in setback areas.	23
Page 90: Are monopoles for telecommunications equipment allowed on campus? If so, SDCI wants to confirm that there is no height limit for these features per the height limit exceptions listed on page 81.	24
Page 90: In some zones in Seattle, minor telecommunications antennas exceeding the allowed height limit are permitted, provided the applicant completes a conditional use permit application. Consider if this process and exception to the height limit would be allowed in the campus MIO area.	25
Page 91: Clarify if a permit is required for temporary structures (including tents).	26
Page 92: Temporary structures final paragraph: the final part of the sentence may be incomplete – is this meant to read “design review”?	27
<u>DEIS:</u>	
Pages 29-30, 42, 206: “Exceptional Trees” have been redesignated as Tier 1 and Tier 2 trees under new legislation. See Director’s Rule 7-2023 for more information.	28

Thank you,

John Shaw
Senior Transportation Planner
Seattle Department of Construction and Inspections

RESPONSE TO LETTER 1

City of Seattle Department of Construction and Inspections

1. Comment noted. The UWMC – Northwest MIMP is based on the requirements of SMC23.69, including section 030 Contents of a Master Plan. All elements are included in the Final MIMP. Please note, the Land Use Code *does not require* illustrating possible building footprints or locations however, multiple DAC presentations, and the Draft EIS studied five potential strategies how the MIMP would be implemented, which include potential buildings, open space areas, circulation and parking. An appendix (F) has been added to the Final MIMP that again provides these five strategies, all of which work within the alternatives presented and studied in the MIMP and EIS.
2. All MIMPs are slightly different, given the unique conditions of their location as well as the differences between educational and healthcare institutions. The UW 2019 Campus Master Plan development standards were used as a guide for the UWMC – Northwest MIMP development standards to ensure all relevant topic areas were included, however it is a much different condition than UW campus as well as most of the other health care institutions. The 33-acre campus has only 2 public rights-of-way and immediate residential neighbors versus the UW's much larger educational campus or the very urban hospital campuses (Swedish Medical Center First Hill and Cherry Hill, Virginia Mason Medical Center, Harborview Medical Center and Kaiser Permanente).
3. A table was prepared and distributed to SDCI and the DAC that includes the following - SMC 23.69.030.C.1 Zoning requirements are addressed. See MIMP Section III (Development Program) for Existing & Proposed Physical development (including Table 3.3), proposed MIO height limits and building setbacks. Section VI (Development Standards) address Building Heights and Exceptions for proposed MIO-allowed heights with proposed rezone. Definitions are provided in Appendix A.

C.2 Development standards are discussed in MIMP Section VI (Development Standards) and are proposed to fit the unique aspects of a campus setting with one or more buildings within a parcel, with shared uses (e.g. multiple uses within a building, shared use of bicycle or auto parking, shared use of loading docks), unique uses for a medical center/major institution, and interior to campus drives that are not public right-of-way. The following development standards are proposed and described within Section VI:

- Bicycle parking
- Blank walls and ground floor façade
- Building heights and exceptions
- Building setbacks

- Landscape and open space
- Lighting Loading berths
- Lot coverage
- Parking and vehicular circulation
- Public street improvements
- Screening
- Signs and banners
- Skybridges and building connections
- Stormwater management
- Telecommunications equipment
- Temporary facilities
- Tower separation
- Venting and exhaust

C.3 Specified development standards are addressed in Section VI of the MIMP include:

- a. Structure setbacks – Building Setbacks
- b. Height limits – Building Heights and Exceptions
- c. Lot coverage – Lot Coverage
- d. Landscaping – Landscape and Open Space
- e. Percentage of MIO District open space – Landscape and Open Space

C.4.a. Transition in height between MIO District and surrounding area – discussed in two places in the MIMP: Section III (Development Program) describes the current Alternative 3 (see Figures 3.17 – 3.21); and in Section VI (Development Standards) for Building Heights & Exceptions and Building Setbacks .

- b. Width and depth limits for structures – see Architectural Guidance, Building Character and Façade Articulation (Section IV – Development Guidance) as well as Development Standards limiting Blank Walls and Ground Floor Facades. The hospital buildings will be the largest building footprints which will be internal to the campus and furthest from campus edges or public rights-of-way. There are no specific limits on width and depth of structures within the campus.
- c. Setbacks between structures – see Development Standards (Section VI) on Tower Separation.
- d. Preservation of historic structures which are designated – There are no federal, state or local designated structures on campus. No structures were deemed eligible during a 2022 study. See Section IV. Project Review. Historic Resources. This section outlines the process to continue to evaluate structures through the life of the MIMP.
- e. View corridors - There are no Seattle designation views in the area of UWMC-Northwest. There are currently no views within or outside of the campus due to the asymmetric development pattern onsite (no long or linear stretches of openings), the tall trees at the boundary of the campus on three sides, and the flat campus topography
- f. Pedestrian circulation within and through the MIO District – see Section III. Development Program for future circulation, parking and wayfinding for pedestrians;

Section V. Design Guidelines provides Access and Circulation Guidance, and Pedestrian Circulation; Section VI. Development Standards for Pedestrian Circulation; and Section VII Transportation Management Program for Pedestrian Strategies.

4. A table was prepared and distributed to SDCI and the DAC that includes the following. SMC 23.69.030.D the Development Program section of the MIMP is self-titled, Section III. Development Program.

SMC 23.69.030. E is addressed in total. See below:

E.1 Physical development alternative proposals – required if an EIS is *not* completed. MIMP Section III, Development Program, describes three alternative proposals in DMIMP and/or preliminary Final MIMP (Section III). Alternatives 1 and 2 were proposed first, with Alternative 3 proposed in response to DAC and community comment. UWMC also provided an EIS analysis of these alternatives.

E.2 Total maximum developable area is stated as 1.6M GSF on MIMP (Section III - Development Program)

E.3 Maximum parking stalls is proposed as 3,300 stalls (Section III – Development Program).

E.4 Existing and planned physical development

a. Height, description, gross area, and existing and proposed planned development – Existing development, including heights and setbacks, is described in Section III (Development Program) of the MIMP, including: heights and setbacks; development illustrated (figures 2.8 and 3.4); planned description and gross area on MIMP (Section III – Development Program); planned heights and setbacks (Section III – Development Program); and Appendix F was added to include Potential Development Strategies illustrating future planned development.

b. Existing and proposed open space and landscaping – See MIMP Section III (Development Program). Section VI. Development Standards address proposed Landscape and Open Space.

c. Existing public and private street layout – see MIMP Section III – Development Program.

d. Existing and planned parking areas and structures – MIMP Figure 3.24 illustrates existing parking. Planned circulation and parking is shown in MIMP Figure 3.25.

E.5 Site plan of UWMC property lines and leases/ownership within 2,500 feet of MIO District – see MIMP Section III – Development Program: MIMP Figures 3.4 and 3.17 show the property lines of the MIO District. UWMC owns all property within the MIO

District. UWMC does not own property outside of the MIO District and within 2,500 feet of the district. UWMC leases clinical care space within 2,500 feet.

E.6 Three-dimensional drawings of existing and planned development – MIMP Section II (Introduction) includes an illustration of existing development and Section III (Development Program) includes an illustration of proposed development. Also see Appendix F and analyses in the UWMC – Northwest MIMP EIS.

E.7 Site plan of any planned infrastructure improvements – Only below ground utilities are proposed and those will be planned along with individual development projects and reviewed by the Implementation Advisory Committee (IAC).

E.8 Planned development phases – Section II Introduction describes the campus needs and how projects will be determined by demand for healthcare services and as funding becomes available. There are no funded projects to date. Appendix F illustrates several potential phasing strategies of how the MIMP might be implemented.

E.9 Planned street or alley vacations – not applicable.

E.10 At the option of the institution, description of uses, development, parking areas/structures, infrastructure or street/alley vacations - See responses to these items above and the location within the MIMP to find these descriptions.

E.11 Proposed MIMP consistency with the purpose and intent of this SMC - The proposed MIMP, including all elements expressed in this matrix in reference to SMC 23.69.030, meets the intent of the Major Institution Overlay District.

E.12 Decentralization plans – see MIMP Section III (Development Program).

E.13 Purpose of the proposed development – MIMP Section II (Introduction) describes the purpose of the MIMP and the public benefits resulting from the proposed development to be able to meet the public demand for medical care.

5. SMC 23.69.030.F.1-2 the required Transportation Management Program is included in Section VII and provides existing and planned parking, loading, bicycle, pedestrian, and traffic circulation systems. This section and the UWMC-Northwest MIMP EIS describe the potential impacts on traffic. This section also includes programs and strategies for reducing auto trips and encouragement of alternatives to single-occupant employee vehicles.
6. UWMC has drafted the Urban Forest Management Plan and is finalizing internal review. The plan will be shared with the City and the DAC when it is completed.
7. Design Guidelines and Development Standards are provided regarding the campus' Landscape and Open Space. The City's major institutions have addressed this requirement

in one of two ways: by identifying significant landscapes (e.g., UW main campus) or defining a minimum required percentage of the campus to be provided as landscape and open space. UWMC – Northwest MIMP Update has defined a minimum percentage of the campus that includes preserving the perimeter tree areas and some additional internal open spaces that will be planned and designed with adjacent campus development. See MIMP Section III Development Standards.

8. No podium height development standard has been proposed. The only buildings that will have separate podium and tower components are inpatient hospital buildings. As presented to and discussed with the DAC at the April 24, 2023 meeting, bed tower floors have smaller floorplates than diagnostic and treatment (i.e., podium) floors which are anticipated as the first 4 or 5 floors below any taller towers. In addition, there are several development standards apply to the ground floor and lower levels of all campus buildings.
9. Design guidance and Development Standards are already included for all signage, including banners. See MIMP Sections V (Design Guidance) and VI (Development Standards).
10. No upper level setbacks or “stepbacks” have been proposed. Incorporating upper level setbacks into healthcare buildings adds significant construction costs for medical office buildings, reduces building efficiency and flexibility and was therefore not proposed for the UWMC – Northwest campus. Inpatient and hospital buildings naturally have some stepbacks as the building transitions from podium floors to bed tower floors; see also response to comment 8 of this letter.
11. The *2024 MIMP Update* includes text revised to reflect the comment. The *2024 MIMP Update* now includes the following: “Reinforce pedestrian routes that connect to transit stops as part of the transit systems quality and level of service” (see the Design Guidance Section, Access and Circulation of the *2024 MIMP Update*).
12. The “where feasible” language is included in the *2024 MIMP Update* as the buildings have not been designed yet, nor has the stops(s) been located yet. As such, the statement is written less absolute in the event environmental conditions or other factors influence the design. The Development Standards Section (Pedestrian Circulation) of the *2024 MIMP Update* includes a standard for minimum 5-foot wide sidewalks.
13. The cited typo in the *2024 MIMP Update* has been corrected. Refer to Section VI (Development Standards) and elsewhere in the *2024 MIMP Update*.
14. The cited typo in the *2024 MIMP Update* has been corrected.

15. The TMP in the Draft *2024 MIMP Update* was a placeholder for a more in-depth version anticipated in the *2024 MIMP Update* after the opportunity for discussion with SDCI and SDOT. The *2024 MIMP Update* has been revised per comment to indicate an employee SOV goal of 50%. See **Appendix B** (Transportation Discipline Report) to this Final EIS for detail.
16. The cited text in Draft EIS Appendix E has been corrected for this Final EIS to be consistent with the table. See **Appendix B** (Transportation Discipline Report) to this Final EIS for detail.
17. **Appendix B** (Transportation Discipline Report) to this Final EIS has updated to reflect 29 deliveries per day.
18. **Appendix B** (Transportation Discipline Report) to this Final EIS has been updated to reflect this comment.
19. The campus transit trips are assigned to be more heavily weighted to Route 345 given its proximity of the transit stop on campus and connectivity to the Link Light Rail Northgate Station.
20. Comment noted. The UWMC will consider additions to the *2024 MIMP Update* annual report through this MIMP development process.
21. The *2024 MIMP Update* has been updated to reflect the proposed height and setbacks.
22. The intent of the *2024 MIMP Update* is to follow the requirements of SMC 23.54.030.L related to EV-ready parking.
23. Text has been added to the *2024 MIMP Update* in Signs and in Building Setbacks sections of the Development Standards to clarify that some signage, as defined, is allowed within setback areas.
24. The *2024 MIMP Update* intent is that free-standing telecommunications equipment, if needed, would be exempt from height limits as indicated in Section VI (Development Standards) of the Draft *2024 MIMP Update*. The *2024 MIMP Update* (Development Standards) now states that free-standing telecommunications, utilities and other accessory communications equipment and flagpoles are exempt from the height controls". The *2024 MIMP Update* also indicates that free-standing telecommunications equipment must be located at least 100 feet from property boundaries if height limits are exceeded. See the Development Standards Section of the *2024 MIMP Update*.

25. Minor telecommunications antennae are a permitted use within the UWMC MIMP and do not require a conditional use permit. Additional text has been added to the *2024 MIMP Update* to cross-reference Building Setbacks and Heights.
26. The *2024 MIMP Update* Development Standards Section indicates that “temporary facilities are exempt from land use procedures.”
27. The cited typo in the *2024 MIMP Update* has been corrected and now reads, “tents are not considered temporary facilities and can be set-up without design review.”
28. The newly adopted redesignation of Exceptional Trees as Tier 1 and Tier 2 trees is noted and updated tree discussion is provided in Section 3 (Updates Subsequent to issuance of the Draft EIS) of this Final EIS.



Date: October 5, 2023
To: Julie Blakeslee, University of Washington Medical Center Northwest
From: Kelsey Timmer, Seattle Department of Transportation (SDOT)
Subject: 3040282-LU at 1550 N 115th St – SDOT Comments on UW Medical Center Northwest DEIS and Draft MIMP

SDOT Comments on University of Washington Medical Center Northwest Draft Environmental Impact Statement (DEIS) and Draft Major Institution Master Plan (MIMP)

Thank you for the opportunity to review UW Medical Center Northwest’s DEIS and draft MIMP. Below is a summary of key Seattle Department of Transportation (SDOT) comments on UW Medical Center Northwest’s DEIS – Transportation Discipline Report (TDR) and draft MIMP. These comments address the scope of analysis and presentation of information included in these documents. Attached is a spreadsheet of the original, written SDOT comments.

Pedestrian, bike, and transit growth

SDOT encourages UW Medical Center Northwest to increase the background growth rate and expected mode split for non-motorized trips to and from campus from that assumed in the DEIS. SDOT expects to see higher background growth in transit, bike, and pedestrian trips due to planned SDOT improvements such as the N 130th St Vision Zero Safety Corridor project and expanded transit service as part of Sound Transit’s Lynnwood Extension. In addition, SDOT expects a higher percentage of project mode split going towards non-motorized and transit trips as a result of programming in the Transportation Management Plan (TMP). As both these interventions are likely to raise the mode share of pedestrian, bike and transit trips, a “more conservative” analysis of impacts to non-motorized modes should assume a higher overall non-motorized mode share. A more robust analysis of trip generation for walk and bike modes, including the origin of trips, walk and bikesheds, and identification of gaps in the resulting network should be performed to fully identify impacts and potential mitigation for these modes.

1

2

3

Vehicle access

SDOT conceptually supports an additional vehicle access point from N 115th St, rather than N 120th St, as N 120th St is a designated Neighborhood Greenway. Neighborhood Greenways are intended to be safer, calmer neighborhood streets where people walking and biking are the priority. SDOT requests the project team study queue length and impacts of the proposed vehicle access point on N 115th St.

4

Proposed mitigation

SDOT appreciates the identification of the level of service (LOS) impacts at N 115th St and Meridian Ave N but does not initially support the proposed traffic signal as mitigation. SDOT is interested to see the impacts of a roundabout studied and compared to signalization. SDOT is also interested to understand how UW Medical Center Northwest proposes to fund a proposed signal at N 115th St and Meridian Ave N. It is unlikely that this intersection would rise to being a priority location for SDOT matching funds to complete installation of a new signal.

5

6

Transportation Management Program (TMP)

SDOT encourages UW Medical Center Northwest to establish a proposed Single Occupancy Vehicle (SOV) rate goal, and to use this goal to guide plans related to transportation and parking facilities. SDOT has concerns with using the 2019 CTR data as a starting point for projections of future behavior. UW Medical Center Northwest is currently failing to meet its existing MIMP-defined goal in its TMP, with a 2019 result of 75% SOV (the existing MIMP goal is 65%). SDOT recommends UW Medical Center NW use the requested analysis of campus transit, walk and bikesheds to inform proposals for substantial investment in non-drive alone programming for employees.

7

8

Please let me know if you have any questions. I can be reached at kelsey.timmer@seattle.gov.

Kelsey Timmer
Development Review Program
Seattle Department of Transportation – Street Use Division

Project Document Date	University of Washington Medical Center (UWMC) Northwest Major Institution Master Plan (MIMP) Update UWMC Northwest Draft EIS and MIMP - Transportation Report 5-Oct-23				
Reviewers	Kelsey Timmer (KT) - Street Use; Alyse Nelson (AN) - Street Use; Isaac Conlon (IC) - Street Use; Katey Bean (KB) - Urban Forestry; Ellie Smith (ES) - Transit & Mobility; Ben Smith (BS) - Transit & Mobility; Mary Catherine Snyder (MCS) - Transit & Mobility; Jonathan Lewis (JL) - Policy & Planning; Aditi Kambuj (AK) - Policy & Planning; Hallie OBrien (HO) - Project Development; Alisa Nguyen (AJN) - Transportation Operations Laura Wojcicki (LW) - Transportation Operations; Tom Le (TL) - Transportation Operations; Band Sittikariya (BS) - Transportation Operations; Nuru Tuku (NT) - Transportation Operations				
Priority codes	1 - Critical issues requiring discussion/resolution 2 - Substantive comment (including issues pertaining to SDOT policy or precedent setting conclusions) 3 - Factual or substantive issue 4 - Editorial comment (suggestion to improve readability of the document or typographical error)				
Page #	Exhibit	Priority	Reviewer comment	Reviewer initial	Transpo Response
393	Transportation Report - Table 8	3	Collision numbers do not match what SDOT database (which is sourced from the WSDOT database) is showing at multiple locations. Please confirm that you have the most up to date collision information from WSDOT.	AJN	The FEIS contains updated data from SDOT
423	Transpiration Report - Mitigation	1	Please first evaluate the use of a roundabout for Meridian and 115th before suggesting a signal. Roundabouts have fewer conflict points, lower long term maintenance costs, and continue to operate during power outages. A compact roundabout may fit (potentially an inscribed diameter of 65'-70'). This approach is consistent with the City's Vision Zero Commitment.	AJN	A roundabout was evaluated as an alternative to a traffic signal. Due to existing bus routes that utilize this intersection, a compact roundabout would restrict turning maneuvers of the buses. Buses and ambulances would need to drive over/through the center of the roundabout to make a northbound left-turn. As this does not appear to be a feasible improvement option. A reference to this analysis is included in the FEIS.
417	Transportation Report - Traffic Operations	2	When looking at impacts of the City's Vision Zero project on 130th St, please also include in the analysis that a no turn on red would be implemented at the signal.	AJN	This has been referenced in the FEIS and the analyses updated to reflect this restriction.
417	Transportation Report - Site Access	2	SDOT Traffic Operations is supportive of having any additional accesses off of 115th rather than 120th due to the presence of a neighborhood greenway on NE 120th St.	AJN	Comment noted. This is reflected in Alternative 3 in the FEIS.
MIMP 47		3	The existing access and circulation section would benefit greatly from more detail on transit access, including which routes are nearby and the relationship between the campus and nearby light rail. This could then be referenced in later sections on future travel trends and in the TMP.	SJS for ES	Additional language has been added to the MIMP to include these references as suggested
MIMP 68		3	In the Transit section, speak to importance of additional lighting, enhanced shelters, and wider sidewalks near transit stops, like the treatments described in the shuttle section (page 69)	ES	The MIMP governs on-site development plans. Assessment of connectivity to adjacent off-campus stops was addressed in the EIS
MIMP 79		3	Please indicate the basis for the bike parking demand study, including when the data was collected and how.	ES	Additional information has been added to the MIMP.
MIMP 79		2	SDOT has concerns with relying on current bike parking demand to determine future planned capacity. The institution should seek to improve facility quality and capacity beyond current usage to encourage mode shift. This could be a key strategy to meet the TMP SOV goal.	ES	The TMP acknowledges the need to monitor and provide adequate bike parking. To that end, the usage will be reviewed as part of the CTR process and at the time of future development within the MIMP to assess and modify the supply as needed. This language is included in the TMP section of the MIMP.
MIMP 79		3	Confirm the ways in which bike parking design meets and exceeds current design standards including how it will be implemented to align with new campus development and circulation patterns.	ES	At the time of project development the applicable SDOT bike parking guidelines will be consulted for the proposed facilities. The quantity of parking to be provided will be reviewed both during the CTR review process and as a part of any specific development applications.
MIMP 79		2	SDOT would urge you to consider multiple long-term bike parking areas to make them more accessible and convenient for employees and visitors, not just one as suggested.	ES	Comment noted
MIMP 84		2	Please indicate the minimum and maximum amount of parking allowed by code, and how this proposal compares. SDOT is interested in seeing UWMC-Northwest limit the amount of parking above the minimum required per SMC. We advise the institution to consider in these early stages how limiting parking (and seeking to not just simply meet anticipated demand) can in turn support your TMP goals, especially by leveraging its relatively close proximity to the growing light rail system.	ES	Due to how staff is assigned and operates with multiple UWMC facilities it is difficult to assess the SMC parking requirements for this facility using the SMC criteria. Staff assigned to UWMC - NW and can travel to different UWMC facilities through the day. Instead the UWMC - Northwest development standards outline a methodology that relies on existing demand and accounts for adjustments based on the current patient space needs, and future reductions in the staff SOV percentages identified in the TMP goal.
MIMP 139		1	A detailed Transportation Management Program needs to be part of the draft MIMP at this stage. The TMP is a necessary counterbalance to the proposed development through the MIMP which allows the institution to identify ways in which their transportation impacts will be mitigated. There is no discussion of mitigation measures in this draft MIMP, and as such, is incomplete and unsatisfactory. Please revise the draft MIMP and include the TMP as a chapter. For reference, the MIMP section of the Land Use Code (23.69.030 F) states: "The Transportation Management Program component shall satisfy the requirements of Section 23.54.016. The Transportation Management Program shall include, at a minimum, the following: 1. A description of existing and planned parking, loading and service facilities, and bicycle, pedestrian and traffic circulation systems within the institutional boundaries and the relationship of these facilities and systems to the external street system. This shall include a description of the Major Institution's impact on traffic and parking in the surrounding area; and 2. Specific institutional programs to reduce traffic impacts and to encourage the use of public transit, carpools and other alternatives to single-occupant vehicles. Any specific agreements with the City for the provision of alternative modes of transportation shall also be included." As currently written, the Draft MIMP does not meet these criteria, and as such does not appropriately identify ways in which TMP measures can offset the trips generated through this proposal. This is a serious oversight and needs addressing.	ES	A TMP chapter has been added to the MIMP consistent with the requirements of SMC 23.54.016.
MIMP 139		2	In response to this language: "The specific programs to be offered by UWMC will be presented to and approved by SDCI and SDOT staff through a TMP-specific review process." In the case of MIMPs, this does not accurately reflect the process. The TMP must be well integrated into the MIMP and part of the same conversation as the development proposal.	ES	Comment noted
MIMP 139		2	It is difficult to assess the TMP without a clearly articulated proposed SOV goal; this SOV goal should be guiding your plans related to transportation/parking facilities.	ES	The MIMP includes a TMP chapter, outlining the SOV goal.
MIMP 139		2	For the TMP, we encourage a more expansive definition of the population beyond what is required to be compliant with CTR. This definition should include all employees (permanent, temporary, contract). Note it is also beneficial to have data on how guests / visitors / patients are accessing the site so that strategies to support those trips can also be woven into the TMP and its implementation.	ES	The TMP provides a refined definition of "CTR Affected" employees.

DEIS P1-21		2	No discussion of mitigation measures associated with trip generation, nor discussion of anticipated mode shift to offset drive alone rate. Mitigation section also doesn't discuss how pedestrian/bicycle trip (identified as impacted on page 1-12) impacts will be addressed through alternatives.	ES	The EIS contains an analysis identifying the increase in non-motorized trips for the campus. The analysis provides information regarding the non-motorized (SW and bike) facilities proximate to the campus. Based on anticipated increases in trip generation and existing facilities, no off-site improvements are identified. The MIMP identifies non-motorized connections within the campus connecting the adjacent ROW.
DEIS 3.6-1		1	The proposed parking appears to be based on current SOV goal (65%) from the existing MIMP. If this understanding is correct, this is not the right order of operations. Through the MIMP planning process, a new TMP will need to be developed to respond to the full MIMP development proposal, including updated SOV goals to align with recent comprehensive plan updates. As such, this calculation for proposed parking would be adjusted based on a new SOV goal.	ES	The recommended parking supply is based on observed rates with adjustments for future development, reduction for SOV rates. While parking supply can be used to disincentivize employee SOV trips, the institution has to balance the parking needs of the patients and visitors, while minimizing overflow into the adjacent neighborhoods. The proposed parking supply cap balances those factors.
DEIS 3.6-2		2	Why is current traffic counts the basis of future activity? We should not assume the same travel patterns will persist, as the institution has a role to play to reduce SOV travel.	ES	The trip generation rates for the campus represents a mix of patients, visitors, and UWMC - NW staff. It is not feasible to separate out the users as parking on campus is shared. For purposes of vehicle impacts, rather than trying to reduce and adjust the trip generation for the change in employee mode splits, the current trip rate were used with the exception of the right-sizing factor. This represents a conservative estimate of the vehicle impacts on the adjacent intersection operations.
DEIS 3.6-3		3	Please indicate the year of the CTR survey, the data referenced here. What is included in your "non-vehicle mode split" - is this simply the non-drive alone rate?	ES	This information has been added to the documentation.
DEIS 3.6-5		3	The statement "There are currently no routes that connect UWMC-Northwest campus to Northgate Station area" is incorrect. Routes 345 and 346 go directly from the Northgate Station to the campus.	ES	This has been corrected in the MIMP and FEIS
DEIS 3.6-5		3	Bicycle and pedestrian mode split. Please indicate the data source/year for the CTR Survey references. Please indicate this data refers to employees only.	ES	Information has been added to the documentation
DEIS 3.6-12		3	Please indicate why 1% was the assumed future ridership rate.	ES	An annual background growth rate of 1 percent was assumed consistent with the annual background growth rate assumed for the traffic volume forecasts. This has been increased to 2 percent which is consistent with the equivalent background annual growth rate at the study intersections when also accounting for the inclusion of pipeline development projects.
DEIS 3.6-19		2	SDOT is very interested in seeing more of the sensitivity analysis referenced here represented throughout this document and in consideration for the TMP to be developed. Since the new SOV goal for UWMC-NW has not been discussed through this MIMP planning process (the current 65% SOV rate is too high per the Comprehensive Plan), it is not useful to include 65% as a benchmark for future behavior. Rather, the sensitivity analysis should be run with the new SOV rate (to be determined in conversation with City of Seattle) to best identify ways in which other modes and parking would be impacted.	ES	The sensitivity analysis addresses a SOV rate of 65% as well as 50%. Both are presented so that the range of SEPA impacts are disclosed in the EIS. The TMP section both in the MIMP and the FEIS has been updated to identify an employee SOV goal of 50%.
DEIS p386		3	DEIS references the Commute Trip Reduction survey as a key data point to complement and build out the trip generation analysis. Please note that the latest valid data was collected in 2019, describing pre-pandemic mobility patterns; SDOT questions the direct relevance of these survey results for inclusion in this report as a basis for future decision-making, given substantial shifts in transportation behavior since the pandemic. There was a 2022 CTR survey administered, for which UWMC NW did not obtain enough survey responses for a successful survey effort (a key component of their ongoing compliance with their MIMP). This is unfortunate, because this is critical information for the purposes of defining current travel patterns and opportunities for future commute trip reduction strategies. UWMC NW is advised to re-survey in Fall 2023. Please describe how this data will be used to influence 3 the transportation analysis for the new master plan.	ES	The 2019 CTR survey is the most recent information available at the time of this EIS publication. An updated CTR survey is expected to be completed in November/December. If the results of the survey are available during this MIMP process, the TMP strategies could be updated if needed or warranted. The core analysis in the EIS assumes the current mode-split, thus provides a conservative estimate of the vehicular impacts on the transportation system as this analysis was conducted assuming a 75% employee SOV rate. A sensitivity analysis for the non-motorized impacts was presented for a 65% and 50% employee SOV rate. Based on previous CTR results, it is expected that these assumptions for the sensitivity analysis will account for any results of a new CTR survey.
DEIS p386		1	SDOT has concerns with using the CTR data as a starting point for projections of future behavior. NWMC NW is currently failing to meet its current MIMP-defined goal in its TMP, with a 2019 result of 75% SOV (their MIMP goal is max 65%). UWMC NW is obligated to meet their MIMP-defined goals as a condition of additional development approval from the City. The City would want to see substantial investment in non-drive alone programming for employees to advance this conversation further. These trip patterns should not be included in the analysis without the necessary context speaking to the obligation the institution has to reduce their SOV trips per the conditions of their MIMP.	ES	A TMP section has been added to the MIMP which includes a statement of the updated employee SOV goal. This has also been referenced in the FEIS.
DEIS p408		2	Thank you for the inclusion of the SOV sensitivity analysis in this updated draft. We look forward to seeing how the TMP SOV goal and measures will be informed by this analysis. Also, it would be valuable to make a better connection between the SOV sensitivity analysis discussed here and the impact different SOV scenarios would mean for the parking proposal discussed elsewhere.	ES	Comment noted. Regarding parking supply rates for the campus, the proposed stall count of 3,300 represents a decrease in the existing rate of 2.59 to 2.06; a 20% decrease.
DEIS P384	Signal operation	3	Hospital entrance at NE 115th St: Since this street is one lane each way and the majority of cars turn right/left to the entrance at NE 115th St, please model it with existing storage space and provide average queue length and average waiting time in queue. Please advise final storage space to accommodate the increased demand volume.	NT	An analysis of the existing and proposed driveways along N 115th Street were included in the DEIS. Widening of N 115th Street at the new signalized access point is proposed to facilitate eastbound left-turn access into the campus.
DEIS P423	Signal operation	3	Meridian Ave NE and NE 115th St: Please model first with roundabout prior to traffic signal. We may have a high demand with Hospital Ambulance traffic to make left or right turn to the hospital at the roundabout, please model it how an emergency vehicle will fit on this operation.	NT	See response above
DEIS P391	Signal operation	3	if it is with the scope of the project please provide separate the left and right turns around the intersections for the WBLT/WBRT at Aurora Ave and NE 115th St	NT	No mitigation is proposed at the Aurora Ave/N 115th St intersection

RESPONSE TO LETTER 2

City of Seattle Department of Transportation

1. The growth rate for background non-motorized trips was increased to 2% based on the review of the equivalent annual growth rate for pipeline and anticipated growth rate at the study intersections.
2. The Transportation Discipline Report (TDR) includes a sensitivity analysis showing the effects of reduced SOV percentage of 65% and 50%, resulting in an increase number of non-motorized and transit reflected in the calculations.
3. Employee zip code data was provided and the map is included in the TDR to help inform where employees are commuting from. More detailed information regarding employee addresses is not possible to provide within this context. A detailed review of availability of non-motorized facilities in the vicinity of the UWMC-Northwest campus is included in the revised TDR and Final EIS including connectivity to transit.
4. Queue lengths at the site accesses is included in the TDR (see Table 24). Additionally, Alternative 3, which is identified as the Preferred Alternative in the TDR and Final EIS, identifies the access via N 115th Street as the preferred third access point option.
5. A roundabout was evaluated as an alternative to a traffic signal. Due to existing bus routes that utilize this intersection, a compact roundabout would restrict turning maneuvers of the buses. Buses would need to drive over/through the center of the roundabout to make a northbound left-turn. Although a roundabout does not appear to be a feasible improvement option, a reference to this analysis is included in this Final EIS (see **Appendix B** - Transportation Discipline Report).
6. Comment noted. The UWMC would be responsible for the costs associated with future improvements identified as mitigation.
7. The operational analysis as presented in the TDR and EIS provides a conservative estimate of off-site traffic operational impacts by assuming the existing SOV rate of approximately 75 percent.
8. The TMP SOV goal has been reduced to 50%. A sensitivity analysis was completed to assess the effects of reduced SOV percentage of 65% and 50% and therefore increased percentages of non-motorized and transit.



HOUSING AND HEALTH
TO END HOMELESSNESS

Letter 3

515 Third Avenue
Seattle, WA 98104
phone: 206.464.1570
fax: 206.624.4196
desc.org

October 5, 2023

Julie Blakeslee
University of Washington
Box 352205
Seattle WA 98195-2205

sent via email to NorthwestMIMP@uw.edu

Dear Ms. Blakeslee,

I am writing to express support from DESC for the proposed UW Medical Center-Northwest Major Institution Master Plan (MIMP).

DESC (Downtown Emergency Service Center) is a Seattle-based nonprofit organization working to help people with the complex needs of homelessness, substance use disorders, and serious mental illness achieve their highest potential for health and well-being through comprehensive services, treatment, and housing. Our vision is a community where no person is abandoned, ignored, or experiencing homelessness. As the region's leading provider of services to multiply disabled adults who have experienced chronic homelessness, DESC serves more than 2,000 people each day. Our integrated service model is designed to help people secure and maintain appropriate, safe and affordable housing.

UW Medical Center, and by extension, UW Medicine, has been an essential partner in meeting the often complex health care needs of individuals served by DESC. In recent years, DESC has significantly expanded our services to north Seattle residents, including opening hundreds of permanent supportive and emergency housing units, and deploying crisis response and outreach services. UW Medicine health care providers are integrated into our facilities, and UWMC-Northwest has been an essential resource in providing health care to the people we serve.

It is imperative that UW Medical Center has the ability to grow to 1.6 million square feet on the Northwest campus to accommodate projected patient demand over the next 10 - 20 years. This is particularly relevant to the growing number of patients who have experienced homelessness, or who presented with a complicated combination of behavioral health and medical conditions. UW Medical Center is uniquely skilled at meeting the needs of these patients, while responding to growing regional demand more generally.



As described in their proposal, inpatient hospital care within the UWMC-Northwest service area is estimated to double over the next 20 years. From 2023 to 2043, inpatient volumes are anticipated to grow by 103%. Outpatient clinical care is estimated to grow by 45% in the same time period. The proposed MIMP would allow the UW Medical Center-Northwest campus to accommodate this increased patient demand.

UW Medical Center has capacity constraints today and requires the ability to further grow as well as upgrade and replace its aging facilities in order to meet the healthcare needs of the community. Additionally, UW Medical Center must have the necessary flexibility to address a dynamic, ever-changing healthcare landscape. DESC supports the proposed MIMP as it enables UW Medical Center to accommodate future growth, replacing aging facilities, improve onsite infrastructure, phase campus expansion, and adapt to changing needs.

We are grateful for our longtime and growing partnership with UW Medicine and UWMC-Northwest. This updated MIMP is necessary in order for UW Medical Center to continue to meet its mission of improving the health of the public.

Sincerely,

A handwritten signature in black ink that reads "Daniel K. Malone". The signature is written in a cursive, slightly slanted style.

Daniel Malone
Executive Director

RESPONSE TO LETTER 3
Downtown Emergency Service Center

1. The comment related to the importance of UWMC-Northwest growth to accommodate future health care needs is noted.
2. UWMC appreciates DESC's support and partnership in meeting the community health care needs and demand.

From: [Lindsey Grad](#)
To: NorthwestMIMP@uw.edu
Cc: [Katharine Weiss](#); [Amber Smith](#)
Subject: support of UWMC – Northwest Major Institution Master Plan (MIMP) submission
Date: Thursday, October 5, 2023 11:47:57 AM

Dear Ms. Blakeslee,

We are writing in joint support of the proposed UW Medical Center - Northwest Major Institution Master Plan (MIMP). Together our unions represent frontline nursing, tech, and service healthcare workers at UW Medical Center – Northwest.

1

It is imperative that UW Medical Center has the ability to grow to 1.6 million square feet on the Northwest campus to accommodate projected patient demand in the coming years. As described in their proposal, inpatient hospital care within the UWMC – Northwest service area is estimated to double over the next 20 years. From 2023 to 2043, inpatient volumes are anticipated to grow by 103%; outpatient clinical care is estimated to grow by 45% in the same time period. The proposed MIMP would allow the UW Medical Center – Northwest campus to accommodate this increased patient demand.

2

UW Medical Center has capacity constraints today and requires the ability to further grow as well as upgrade and replace its aging facilities in order to meet the healthcare needs of the community and for our members to provide this care in an appropriate setting. Additionally, UW Medical Center must have the necessary flexibility to address a dynamic, ever-changing healthcare landscape. We support the proposed MIMP as it enables UW Medical Center to accommodate future growth, replacing aging facilities, improve onsite infrastructure, phase campus expansion, and adapt to changing needs.

3

This updated MIMP is necessary in order for UW Medical Center to continue to meet its mission of improving the health of the public.

4

Sincerely,

Lindsey Grad, Legislative Director – SEIU Healthcare 1199NW

Katharine Weiss, Government Affairs Director – Washington State Nurses Association

Lindsey Grad

Legislative Director

SEIU Healthcare 1199NW

c: [425-919-9018](tel:425-919-9018)/lindseyg@seiu1199nw.org

RESPONSE TO LETTER 4
SEIU Healthcare & Washington State Nurses

1. The comment supporting the proposed *2024 MIMP Update* is noted.
2. The comment related to the importance of UWMC-Northwest growth to accommodate future health care needs is noted.
3. The comment related to the need to upgrade aging facilities and need for development flexibility to address healthcare needs is noted.
4. Comment noted.



JOHN T. (J.T.) COOKE
ATTORNEY
JT@HOULIHAN-LAW.COM

October 2, 2023

VIA EMAIL (northwestMIMP@uw.edu)

Julie Blakeslee
University of Washington, Box 352205
Seattle, WA 98195

RE: UWMC—Northwest Major Institution Master Plan
Draft DEIS Comments from the Stendall Homeowners Association

Dear Ms. Blakeslee:

We represent the Stendall Homeowners Association (“Stendall HOA”) and submit these comments on the Draft Environmental Impact Statement (“DEIS”) for the UWMC Northwest Major Institution Master Plan. The Stendall HOA consists of owners of the 67 residential units in the planned unit development adjacent to the UWMC Northwest campus commonly referred to as Stendall Place.

The Stendall HOA has two members that have participated in the Development Advisory Committee (“DAC”). Stendall HOA has coordinated with its representatives on the DAC to participate and offer comments important to Stendall HOA that would allow the UWMC to meet its expansion needs while minimizing noise, shading, air pollution, traffic and other significant impacts that development under the proposed Master Plan would have on the residents of Stendall Place. Despite the UWMC’s commitment that it would “engage with members of our community to understand and incorporate [the communities’] priorities into the proposal” the proposed Master Plan and DEIS does not incorporate or address any of the priorities raised by its members through the DAC process. This has left Stendall HOA with the unsettling feeling that DAC process is process for process sake and that the UWMC is prioritizing its preferences over the reasonable concerns of its neighbors.

1

General Comments

The proposal is qualified as a non-project proposal for purposes of the SEPA review. As a result, the DEIS does not conduct site specific analysis of impacts and instead addresses impacts at a more general level. Under this approach the significant impacts of actual development often evade detailed environmental review. Following a master plan approval, local jurisdictions often determine that the actual project’s impacts will be mitigated through its own development regulations and comprehensive plan and do not require additional EIS review. This approach deprives the community of meaningful input into the actual development design through the SEPA process.

2

This is especially problematic here because UWMC has not assessed impacts under a “worst case scenario”. For example, and without limitation, the view and shading analysis does not assess the impacts

3

of possible developments that occupy the full vertical footprint the proposed master plan allows. Additionally, the Draft EIS readily concedes that certain portions of the proposed master plan like the loop road would “be development in phases” thereby creating the potential for piecemealed environmental review of the project whole. The failure to assess impacts from the full build-out allowed by the proposed alternatives renders the DEIS deficient.

3 Cont.

4

Stendall HOA requests that the UWMC commit to conducting a Supplemental EIS for specific development under the proposed Master Plan that gives the neighboring community the opportunity to have input into specific development proposals allowed by the Master Plan. In the event the UWMC will not commit to conducting a Supplemental EIS, Stendall HOA requests the UWMC delay revising its master plan until it has a better idea of what it wants to build and where. This would allow for a more tailored master plan proposal and a more meaningful engagement with the surrounding community.

5

Specific Comments to DEIS

1. Campus Access

Stendall HOA opposes non-emergency access to the UWMC campus from North 120th. The DEIS does not adequately assess the impacts of proposing general access from North 120th. Adding a general access point to the campus from North 120th would shift traffic patterns away from arterials and into the surrounding residential street grid. The existing road conditions in this area are not designed to handle traffic for a major institution of the size proposed in the DEIS alternatives. The portion of North 120th abutting the campus and much of the adjacent street network are not to standard. Most intersections are uncontrolled and lack signs or lights to direct traffic safely through intersections. There are no sidewalks. The street surfaces are narrow, do not have shoulders and do not have lane lines. Creating access on North 120th without massive, full-width improvements to the abutting and surrounding street network would create an unacceptable risk to public safety.

6

In short, adding a general access point to the campus from North 120th is not a viable alternative and should be removed from the DEIS.

2. Height, Use Intensity and Setbacks

The DEIS does not adequately assess the impacts the increased building heights will have on the surrounding communities. The building themselves will have visual and shading impacts that have not been adequately assessed. As noted above, the Master Plan proposed significant height increases but the analysis of the impacts from those height increases is based on significantly lower development scenarios. Figures 3.4-15 is illustrative. It depicts a 45’ foot proposed building to assess the view impacts of a 105-foot proposed building envelope. The full impacts of the building envelopes should be assessed so adequate mitigation and plan changes can be assessed including increased buffers and tiered building setbacks. Likewise, the shading and view assessments are not taken from high impact areas. A shading and view assessment should be conducted from adjoining residential neighborhoods including, but not limited to, Stendall Place.

7

8

Additionally, increased height will increase the intensity of the use on the campus. The increase in intensity of use will create more noise, more light pollution and more air pollution. Despite these impacts

9

the proposed alternatives keep the existing setbacks relatively static. Alternative 2 proposes the same 30' setback adjacent to Stendall Place and Alternative 1 increases the setback a paltry 10 feet. The proposed setbacks do not sufficiently offset the impacts from the increased height and intensity of use. Stendall HOA requests a minimum 75' vegetated setback between the Stendall Place Property and the UWMC Northwest campus. The current 30-foot setback sufficiently buffers the impacts from the low intensity, 12-foot E-Wing that is adjacent to Stendall Place but is not remotely sufficient to buffer Stendall Place from the visual, shading, noise and air pollution impacts that will be generated by the 105-foot (and taller) buildings that would be allowed under the proposed alternatives.

10

11

There is precedent for a 75' setback for major institutions like UWMC Northwest. The Final Master Plan for Seattle Children's establishes a 75' vegetated setback for the portions of its campus that abut residential neighborhoods. UWMC Northwest should be making similar changes to the setbacks to offset the impacts of more intensive development on the campus.

12

3. Loop Road

The impacts the loop road will have on adjacent residential properties has not been adequately analyzed. The Master Plan proposes a general circulation road directly adjacent to the Stendall HOA and in the proposed building setback. Although the UWMC can anticipate its future growth demands it provides no analysis of the expected trip counts that will likely use various portions of the loop road. There is no assessment of how noise generated by traffic on the loop road will impact abutting residential properties. There is no analysis of glare from headlights that will intrude into adjoining residential property. The absence of any meaningful analysis of these issues precludes the development of mitigation measures required by SEPA and serious consideration of design changes that address community concerns.

13

Likewise, the location of the loop road conflicts with other provisions of the DEIS. The description of both alternatives states that the setback area is intended to preserve existing tree canopy. Yet, both alternatives place the loop road within the setback adjacent to the Stendall HOA property. Stendall HOA requests that the loop road adjacent to Stendall Place be located outside of the proposed setbacks.

14

In short, Stendall HOA understands that UWMC Northwest is a regional facility that needs to expand to meet the demands of a growing population. We believe that UWMC's reasonable growth needs can still be accomplished while addressing these priority concerns and minimizing the impact that more intensive use will have on the residents of Stendall Place.

15

Thank you for considering these comments.

Sincerely,



John (JT) Cooke
Attorneys for Stendall Homeowners
Association

Cc: Client (via email)

RESPONSE TO LETTER 5

Stendall Place Homeowners Association

1. The UWMC is grateful for the DAC members' participation and guidance throughout this process. DAC comments on the preliminary draft documents influenced the published versions and many –but not all– changes were made in the Draft *2024 MIMP Update* and Draft EIS. As the DAC was informed, this is an iterative process and comments from the general public and the DAC will continue to impact the development of the MIMP.
2. As indicated in the Draft EIS Fact Sheet (page iii) and Chapter 2 (2-12) of the Draft EIS, approval of the *2024 MIMP Update* is classified under SEPA as a non-project action (also referred to as programmatic). A non-project action is defined as an action that is broader than a single specific project, and involves decisions on policies, plans, or programs. A non-project Environmental Impact Statement (EIS) addresses conditions at a more general level (WAC 197-11-442). However, as possible, the Draft EIS includes detailed information and analysis, including use of transportation modeling, greenhouse gas emission calculations, building massing view simulations, and shadow diagrams, which provides a level of detail beyond that of the typical non-project environmental review.

When future specific individual projects under the *2024 MIMP Update* are proposed, the University of Washington (as SEPA lead agency) will conduct a review of the project to confirm consistency with the *2024 MIMP Update* and *EIS*, and will prepare project-level SEPA environmental review as needed.

In addition, the Implementation Advisory Committee (IAC), the successor community committee to the current Development Advisory Committee (DAC), will be formed and review each development project for consistency with the MIMP Development Standards.

3. As indicated in Section 3.4 (Aesthetics/Light & Glare/Shadows) of the Draft EIS, because specific projects are not defined in the *2024 MIMP Update*, for purposes of environmental analysis building massing scenarios were prepared to represent the extent to which new building massing could occur on campus, consistent with the proposed total building square footage, building height overlays, perimeter building setback areas, and reasonable building development patterns considering health care needs (including proximity to the existing patient tower and emergency access). The massing scenarios include a scenario with building massing in the northern portion of campus in proximity to Stendall Place. The massing scenarios were then utilized for the visual simulations and shadow diagrams prepared for the Draft EIS. Where the viewpoint location is setback sufficiently, the visual simulations also include illustration of the location of the 175-foot, 105-foot, and 65-foot building height overlays considering perimeter building setback areas to illustrate the overall potential building development envelope under the *2024 MIMP Update*. Refer to

response to comment 7 of this letter for further detail on the view analysis prepared for the Draft EIS.

For the Draft EIS shadow analysis, shadows for three times of year are analyzed including the Vernal Equinox, Summer Solstice and Winter Solstice; shadows during the Autumnal Equinox would be the same as those occurring during the Vernal Equinox. As indicated on page 3.4-39 of the Draft EIS, potential future development under the *2024 MIMP Update* would result in an increase in shadows associated with new buildings and associated campus landscaping. The shadow diagrams illustrate that shadows under the *2024 MIMP Update* would generally be cast over areas that already receive shadows from mature trees and existing buildings.

As indicated on page 3.4-38 of the Draft EIS, all potential development projects under the *2024 MIMP Update* would comply with the University's design review process (architectural review and environmental review) which would include review of building orientation, building height, and the potential to cast shadows.

4. A campus loop road is proposed to be developed in phases with adjacent development and may be located within building setback areas. The loop road would be required to be located at least 20 feet from property edges abutting residential neighbors (measured from the nearest back of curb), with substantial vegetation screening provided between the loop road and abutting residential properties. Non-emergent vehicular circulation on-campus would be limited to posted 15 miles per hour.

Refer to Section 3 (Updates Subsequent to Issuance of the Draft EIS) for discussion on conditions with proposed loop road. As indicated in Section 3, no significant adverse impacts were identified due to the low speeds, typical time of day use, distance between the road and adjacent residential uses, and substantial vegetative screening.

5. The comment request for preparation of a Supplemental EIS is noted, as is the request for delay of MIMP revision until specific projects are identified, the latter of which does not meet the intent of the City of Seattle Major Institutions code.
6. The traffic and safety impacts associated with the optional access from N 120th Street were evaluated in the EIS. The traffic impacts associated with the N 120th Street access (access Option 2) are summarized in Table 3.6-7 of the DEIS. Table 3.6-7 of the DEIS shows the overall operations of the two existing access points along N 115th Street are forecast to operate with less overall delay and queueing with Option 1 (via N 115th Street) compared to Option 2 (via N 120th Street) as the traffic signal is able to accommodate additional demand and is generally located where more users are naturally inclined to utilize (consistent with distribution patterns). At the time of writing, a sidewalk along the entire length of the medical center property on N 120th Street was under construction. The DAC members have been aware of this project for several months. The *2024 MIMP Update* and

Final EIS identifies N 115th Street as the preferred location for a third driveway in Alternative 3.

7. Section 3.4 (Aesthetics/Light & Glare/Shadows) includes a comprehensive analysis of potential view conditions under the proposed *2024 MIMP Update*. The analysis includes visual massing simulations prepared for Alternatives 1 and 2 based on photographs of the campus from selected viewpoints and simulations of potential development from these viewpoints. The identification of viewpoints for the visual analysis was based on the availability of views to potential development on campus from publicly accessible areas in the vicinity. Seven viewpoints were selected as being most representative of area views and/or were determined to have the greatest potential for development under the *2024 MIMP Update* to change the character of the view.

Because specific projects are not defined in the *2024 MIMP Update*, simulations of four building massing scenarios were prepared for each viewpoint representing the extent that potential building massing would be visible from the respective viewpoints, consistent with the assumed total building square footage, building height overlays, and perimeter building setback areas. In general, the massing scenarios simulated for this EIS include: *Scenario 1* with a dispersed development pattern; *Scenario 2* with a development pattern focused in the central and southern portions of campus; *Scenario 3* with a development pattern focused in the central and western portions of campus; and, *Scenario 4* with a development pattern focused in the central and northern portions of campus. In addition, where the viewpoint location is setback sufficiently, the visual simulations include illustration of the location of the 175-foot, 105-foot, and 65-foot building height overlays considering perimeter building setback areas (i.e. building development envelope) to illustrate the potential building envelope within which development could occur under the *2024 MIMP Update*.

Thus, the visual analysis prepared for the Draft EIS both illustrates a variety of potential building massing scenarios as well as illustrating the overall building development envelope as viewed from surrounding public areas, and adequately analyzes the potential for views to campus development under the *2024 MIMP Update*.

The *2024 MIMP Update* does not present a final design. Alternatives identified in the Draft *2024 MIMP Update* propose new building height overlays and setbacks across the campus to facilitate development up to 1.6 million SF. Several potential scenarios of how different projects might fit within that zoning have been tested. It is anticipated that few buildings would utilize the maximum building height and exact locations, dimensions and orientation is not yet known. View studies and shadow analyses are included in the Draft EIS for the proposed height overlays as well as reasonable assumptions to building massing to indicate potential impact. Future building proposals meeting the MIMP standards would be subject to further evaluation and review by the Implementation Advisory Committee to confirm building design is within what was anticipated.

8. The identification of viewpoints for the Draft EIS visual analysis was based on the availability of views to potential development on campus from publicly accessible areas in the adjoining neighborhoods; no private properties were accessed for viewpoints. However, both Viewpoint 5 (Ashworth Avenue N/N 120th Street looking southeast) and Viewpoint 6 (Stendall Drive N looking east) were specifically chosen for analysis because they are adjacent to privately-owned Stendall Place and reasonably reflect the potential for views to development under the Draft *2024 MIMP Update* from Stendall Place.

The shadow simulations prepared for the Draft EIS were completed to provide a comparison of existing shadow conditions and shadow conditions under the Draft *2024 MIMP Update* (Alternatives 1 and 2) for three times of the year (vernal Equinox, Summer Solstice, and Winter Solstice). The shadow simulations illustrate the anticipated potential for shadows to affect adjoining residential neighborhoods, including Stendall Place; see Draft EIS Figures 3.4-1 through 3.4-21.

Views were assessed from public rights-of-way surrounding the property. Solar analysis was conducted for the entire campus and potential impacts under the Draft *2024 MIMP Update*.

9. Comment noted. As indicated on page 3.1-7 (Land Use) of the Draft EIS, implementation of the level of development contemplated under the Draft *2024 MIMP Update* would result in an intensification of uses on campus, replacement of existing buildings, and increases in activity levels based on the increase in campus population (staff and visitors). The increase in campus population over the 20-year *MIMP Update* planning horizon would result in associated increases in traffic, air pollution emissions, noise, and lighting on and adjacent to campus. The Draft EIS describes anticipated air quality, lighting, and traffic conditions associated with proposed increase in building density; see Draft EIS Section 3.2 (Air Quality/GHG Emissions), Section 3.4 (Aesthetics/Light & Glare/Shadows), and Section 3.6 (Transportation) for detail.
10. An intent of the *2024 MIMP Update* is to develop consistent, equitable setbacks for all neighboring conditions. Alternatives 1 and 2 tested 30-foot wide and 20-foot wide setbacks (respectively) where abutting residential parcels, across the whole site. Note that Alternative 3 (Preferred Alternative) reflected in the *2024 MIMP Update* and provided for this Final EIS includes a 40-foot wide perimeter building setbacks where the campus abuts residential parcels to the east and west, and abuts the N 120th Street right-of-way to the north.
11. Request noted. The current MIMP allows 37-foot high development and a 30-foot setback. Building E is a good example of UWMC development not utilizing all of the allowed height for a particular project within the existing MIMP agreement. UWMC is studying the

requested height/setback areas to test if it precludes development of the 1.6 million square feet, given phasing and operation requirements to build additional capacity before demolition of any older buildings. An additional alternative (Alternative 3) proposes 40-foot wide perimeter building setbacks and 65-foot maximum building height overlay nearest the Stendall Place properties. Additionally, language has been added to the development standards of the *2024 MIMP Update* to limit potential location of any loop road driveways no closer than 20 feet from the property edge.

12. Comment noted. Each of Seattle's major institutions have very different physical and regulatory conditions; the MIMPs for each campus guide development. Seattle Children's also has significant topography and steep slope areas that impact how that campus will develop.
13. The loop drive has not yet been designed. UW is committed to improving circulation on-campus for pedestrians, bicycles, autos, trucks, and ambulances to and from the access points on N 115th Street. This requires the ability for vehicles to loop through the campus. Design guidance and development standards have been defined to help address potential light conditions, including provision of perimeter screening with vegetation and shielding of roadway lighting fixtures.
14. Location of the loop drive has not yet been determined. Portions of campus circulation may occur within building setback areas; however, design guidance (Site Design) defines several ways to employ landscape, lighting and screening to help protect campus' neighbors. Note that the *2024 MIMP Update* indicates that the loop road would be located a minimum of 20 feet from abutting residential properties, provision of substantial landscape screening, and posted speed limit of 15 mph. When a specific design of a loop road (or segment of the loop road) is proposed, the University of Washington as SEPA lead agency will conduct project-level SEPA environmental review as needed.
15. The comment regarding accommodating campus growth while minimizing impacts to Stendall Place is noted. Stendall Place is identified in the Draft EIS as an adjacent use that could be impacted by increased campus density under EIS Alternatives 1 and 2. Based on analysis conducted for the Draft EIS and DAC and public comment received on the Draft EIS, an additional Alternative (Alternative 3) is included for analysis in this Final EIS.

October 25, 2023
Holly Godard/ John Shaw
Seattle Department of Construction & Inspection
700 Fifth Avenue, Suite 2000
P.O. Box 34019
Seattle, WA 98124-4019
Via e-mail: holly.godard@seattle.gov; John.Shaw@seattle.gov

Re: UWMC – Northwest Committee Comments on Draft MIMP and DEIS

Dear Ms. Godard and Mr. Shaw,

The UWMC Northwest Major Institutions Master Plan (MIMP) Development Advisory Committee (DAC) is charged with advising the City and UWMC Northwest concerning the development of the new UWMC Northwest MIMP. The DAC had the opportunity to review presentations on Draft MIMP and Draft EIS for UWMC Northwest Hospital.

The DAC looked carefully at what the proposed expansion would look like and how UWMC Northwest's proposed alternatives would impact the neighborhood and the range of people who live, work, go to school, or play in the area. We believe it is our role to balance the growth of the University with the long term needs of the community. To that end we offer this Draft comment letter for your consideration.

The methodology used to prepare these comments included creating targeted subcommittees to review each subject matter and provide a summary and proposed comments for review and discussion with the whole committee. The designated subcommittees were as follows:

- Traffic, Parking, Access and Circulation- Karoline, Susan
- Landscape, Open spaces and Tree Preservation, Aesthetics, Stormwater management - Andy, Kippy
- Views, Shadows, Air quality, Noise and Utilities: Infrastructure - Carol, Keith, Kevin
- Land Use: Height, bulk and scale, setbacks- Scott, Joan and Shawn

These comments and discussion were then summarized by Karoline and Kippy with additional input from subcommittee members as appropriate.

For the Committee,

Scott Sheehan and Andy Mitton,
Committee Co-chairs

Opening Statement and Summary

UWMC Northwest campus is an asset to the Haller Lake and Northgate community. All DAC members feel it is an honor to be part of this committee and grateful that we have been given the opportunity to provide our comments on the UWMC - NW draft MIMP and EIS. We all understand that UWMC - NW needs to grow and update many of its facilities. We represent the community surrounding the hospital and our goal is a successful outcome for positive change for both the hospital and the community. There are many seniors, adults, and young families that live near the campus and walk/run/ bike commuters passing through and near the campus. We ask that they are all considered in the proposed campus design and also considered in minimizing the associated construction, noise and pollution impacts.

We have a very friendly, active community that will help make this campus wonderful if you design it to welcome and integrate them. The hospital has been a great neighbor since inception, and it is in the best interest of everyone to continue to do so. The recommended revisions that we have identified as having the strongest impact on the community can be summarized as follows:

- Prohibiting new vehicular access point from N 120th Street while maintaining the existing locked access gate for emergency access, short term construction, and deliveries that exceed clearances at the pedestrian bridge on campus
- Locating the tallest structures only near the central or southern areas of the property
- Allowing parking garages at the south and southern half of west property line, where not directly adjacent to residential structures
- Increasing the setbacks abutting and across from residential parcels
- Restricting building height near residential property lines
- Maintaining trees and vegetation on the property now, during and after the development

Traffic, Parking, Access, and Circulation

General Intent & Recommendations

Primary concerns regarding traffic, parking, access and circulation include allowing vehicular access only via N 115th Street; maintaining sufficient distance between the loop road and adjacent residences; and siting parking structures in appropriate locations.

Specific Comments regarding Preliminary Draft MIMP

Section III - Development Program

Existing & Proposed Physical Development – p.31

- We recommend that this section acknowledge that N 120th St ONLY connects back to Meridian to the east. Traveling North on Ashworth does NOT link to any other arterials, it enters a residential labyrinth back to 122nd / Densmore that circumnavigates Haller Lake before connecting to N 125th St or 1st Ave.

2

Campus Circulation, Parking & Wayfinding – p.47

- We recommend that this section acknowledge anecdotal evidence of overflow parking onto adjacent residential streets, either due to limited availability of onsite parking or parking fees discouraging use.
- We recommend that this section acknowledge that Medical Center Use / Occupancy is not subject to the same user-group decision-making processes as other Uses / Occupancies. For example, an office worker is more likely to consider public transportation or carpooling opportunities when parking is limited at their place of business, but Medical Center user-groups are limited by the following factors:

3

- Staff must arrive on-time to staggered shifts, often in misalignment with frequency / availability of public transit OR not allowing ride-share for people who live near each other.
- Patients are often not repeat users who can test various access methods to make a conscious choice of their commute methods. Also, patients presumably have a higher tendency towards mobility issues than the general public, making public transit less desirable and bicycle/walking unfeasible. Furthermore, arriving for any medical treatment or diagnosis is a stressful event that triggers selection of one's default transportation mode (typically single-occupant vehicle) for emotional safety.
- Visitors are more infrequent than patients so are also unlikely to carefully consider their transportation choices.

4

- We recommend adjusting Fig 3.20 “Proposed Circulation Diagram” as follows:
 - Add note to loop road along west property line adjacent to residential parcels to indicate “Restricted to Fire Lane Only”
 - Remove option for Potential 3rd Access at N 120th St. Recommend the two “Potential Garage Locations” in the SE and SW corners of the site be noted as “Preferred Garage Locations”

5

- Revise the text at two “Potential Garage Locations” in the SE and SW corners of the site be noted as “Preferred Garage Locations” but clearly indicate that garage entry/exit will not require a new curb-cut at N 115th Street. Trees in this area should be protected.
- Revise the text in the NE corner to read “Potential Development” without noting this a potential garage location.

5 Cont.

Section V – Design Guidance

Access & Circulation – p.70

- Require additional parking stalls must be constructed in tandem with growth, calibrated to increased capacity.

6

Section VI - Development Standards

Bicycle Parking - p.79

- Recommend referencing SMC 23.54.015.K for minimum bicycle parking requirements.

7

Loading Docks - p.83

- Recommend adding language to require visual & noise screening from adjacent property lines, as close to the loading areas as possible.

8

Parking & Vehicular Circulation - p.84

- Recommend that the language "may" be changed to "shall" in this section.
- Recommend referencing SMC 23.54.015, Table C for Institution Parking Minimums AND note that precedence has been set for increasing maximum allowable parking spaces in the Northgate Overlay District to accommodate overflow during peak hours.
- Recommend raising allowable maximum and mandatory minimum number of parking stalls to prevent overflow into adjacent residential zone.
- Recommend noting that all vehicular traffic (except emergency fire lane) must be inboard of the property setbacks, particularly in the northeast corner adjacent to Stendall Place.

9

Pedestrian Circulation - p.85

- No comment

Public Street Improvement - p.85 - 88

- We recommend that a 3rd entrance be on N. 115th St. and that the N. 120th St entrance be removed from the MIMP as an option. If the North Entrance to N 120th St will continue to be a required option due to UWMC functional requirements, the following minimum improvements will be required:
 - Improvements to entire vehicular path of travel from north to connect to Aurora Ave N and N 130th St at 1st Avenue, including ROW improvements to sidewalks, gutters, street trees, landscape buffers, signaled crossings, bike lanes, etc. should the N 120th St entrance be required by the UWMC-NW for continued operations. These would be of

10

particular importance considering increased pedestrian & bike traffic to/from the lightrail stations at 130th.

10 Cont.

Specific Comments regarding Preliminary Draft EIS

Section 3.6 Transportation

3.6-2 Trip Generation

- Recommend clarifying if traffic counts include only entries/departures to/from campus boundaries or include adjacent street parking.

11

3.6-4 Street System

- Recommend clarification - Identifies N 120th St as a non-arterial. How does an additional entrance point here support the stated goal of "reduce neighborhood impact"?

12

3.6-5 Traffic Volumes

- Recommend studying intersections that did not include baseline LOS for other intersections that would presumably be impacted by a N 120th St entrance, namely:
 - Meridian Ave N @ N 122nd St
 - Densmore Ave N @ N 122nd St
 - Densmore Ave N @ N 125th St
 - Corliss Ave N @ 1st Ave N
- Note: Study of these intersections likely not required if vehicular access from N 120th St is removed from proposed MIMP
- Recommend analysis of emergency vehicle access

13

3.6-17 Transit

- No changes are proposed but recommend a shuttle and/or bus route to the light-rail stations to be considered to encourage ridership & reduce single-occupant vehicle trips.

14

Landscape, Open spaces and Tree Preservation, Aesthetics, Stormwater management

General Intent & Recommendations

We recommend that UWMC NW articulate a campus-wide design concept of creating a medical center within a healing northwest lowland forest environment. This concept would include the below intent statements and recommendations of this section to direct performance outcomes that create a healthy forest environment with state-of-the-art water management, urban forestry management, patient and visitor flowing access in and around the medical campus and a nature walking path around the perimeter. Chief Luther Standing Bear in T.C. McLuhan’s Touch the Earth stated, “It was good for the skin to touch the Earth and the old people liked to remove their moccasins and walk with bare feet on the sacred Earth... the soil was soothing, strengthening, cleansing and healing.”

15

INTENT Statements:

- The intent around landscaping could include more clarification about planting drought tolerant plants that are adaptive to climate change and that are designed to last sustainably.
- The intent around open spaces is good.
- The intent around tree preservation is limited. Please highly value your mature and exceptional trees, replacing them takes time we don’t have! Water scarcity is a problem in our country (and the world) and established trees are a to feed deep water systems that are so important for our survival.
- The intent around Aesthetics is good and we have some comments below associated with architectural guidance and screening.
- The intent around stormwater management on the property could be more resourceful based. Finding ways to create designs that absorb and hold water on the property in a managed landscape (Green low impact development techniques). Due to tree removal on the property and global warming impacts, good water retention management is/ will be invaluable for the properties landscape, open spaces and tree preservation. Combining landscape and stormwater for dual benefits is a win/ win.
- The intent around sustainability is ok. For landscape, consider other environmental certification processes, such as Living Building Challenge or SITES.
- The intent to keep the existing Greenbelt on the East and West Property lines is good. It shall be maintained & kept as a Greenbelt for during future developments.

16

17

18

19

20

RECOMMENDATIONS:

We recommend that the information in the above comments be added somewhere within the intent of the MIMP:

- We recommend UWMC NW manage a tree replacement policy that meets sustainable tree canopy coverage on the campus that is resilient to climate change. Ensuring new tree plantings

21

are done responsibly, varying the species and varieties of trees to avoid monocultures, and spacing trees for long term health and sustained success. This should be coordinated with the Urban Forestry Management Plan.

21 Cont.

- We recommend for mature/ exceptional tree preservation that there is no new site development (i.e., roads, parking lots...) in all setbacks around the perimeter of the property where existing mature/ exceptional stand/grow.

22

- We recommend encouraging mature and exceptional preservation whenever possible during this MIMP development. And if ground disturbance is required that removes significant tree roots and reduces available water, that it be required to have stormwater diverted to supply natural water to the tree. Supplemental irrigation can also be considered.

- We recommend removing existing landscape cloth or fabric (and avoid using cloth in the future) anywhere on campus as part of new landscape development in order to increase soil health, water absorption and tree preservation.

23

- We recommend if lower roofs are visible from upper floors, incorporate green roofs or terraces as a means to mitigate visual impacts, reduce heat island effect, and enhance the aesthetics of the healing nature concept.

24

- We recommend noting that setbacks should be vegetated to provide maximum buffer at residential property lines.

25

- We recommend creating a nature walking path that is a partially woodchipped (or other pervious surface) trail and a partially paved path that loops the perimeter setback area of the property. The paved path areas would link with other paved loops within the campus at the woodchipped areas. This way there would both be a part of the path that would be connecting to the earth for those that choose and a paved connection for those unable to use the woodchipped paths. This accessible path will wind within the mature/ exceptional trees and be complemented and supported by native shrubs and ground covers. This will strongly support the full campus concept of HEALING IN THE FOREST with a true forest-like perimeter.

26

- Benefits patients, staff, local community and the environment
- Supports existing trees to stay healthy
- Support to stormwater management
- Supports pollinators
- Great demonstration of sustainable development

- We recommend that a high carbon sequestering/ long living tree (such as oak, Douglas Fir, pines, blue spruce) is planted on the property for exceptional trees removed (noting that only poor condition exceptional trees may be removed):

27

- to be planted in different areas around the property (not side by side for long term health)
- to support needed carbon sequestering
- to help to improved stormwater runoff
- to help improve deep water charging lost with old tree removal
- helping to lower global warming impacts on the property and in the community

- We recommend all other trees removed from the property (due to poor health) follow the Urban Forestry Management guidelines for tree replacement. | 28
- We recommend for architectural guidance a stronger consideration for how modulation to the building massing could limit impacts to adjacent neighbors, in particular Stendall Place. Consider providing more specific dimensions for the length of a side facade before a recess, or other building setbacks may be required to allow more light to adjacent developments. Consider how window placement on side facades can maintain the privacy of dwelling units by minimizing placement of windows where they directly align with neighbors' windows within 20 or 30 feet of the side property line. We like the example given in the meeting about clerestory windows, or translucent windows, but could not find reference to this in the MIMP. | 29
- We recommend changing the wording in the screening section that noise producing equipment be screened with walls or other sound absorbing built elements that support vegetation or planted green screens, etc. (vegetation alone will not mitigate noise impacts). Acoustical mitigation can be through screening or choice and location of equipment. | 30
- We recommend adding a section in screening that addresses how fencing, landscaping, or other techniques to buffer dwelling units along a side lot line should be scaled appropriately to provide privacy and allow light and air circulation. | 31
- We recommend considerations for permeable pavements as part of a kit of parts that could be used in different applications on campus as applicable. | 32
- We recommend that there is an intent about designing stormwater management to be an asset that is used in the landscape and open spaces whenever possible before going to the retention tanks or catch basin filtration. We feel these gray infrastructure techniques should be a last resort only when needed (or as a supplement to green infrastructure). | 33

Specific Comments regarding Preliminary Draft MIMP

Section III - Development Program

Open Space, Landscape and Trees - p.43

- Paragraph a. - Revise the terminology from "several" mature trees to "many" mature trees. | 34

Section V – Design Guidance

Infrastructure - p.72

- Stormwater – Revise to include the following "accommodating on-site mitigation when necessary to embrace a holistic, naturalized landscape character while preserving accessible open spaces". Incorporate language that requires the use of surface stormwater management tools such as: rain gardens, bioswales, wood chips to improve soil condition for rainwater absorption and retention, and similar that could be integrated with accessible open spaces. | 35

Specific Comments regarding Preliminary Draft EIS

Section 3.7 Utilities

3.7-7 Onsite Stormwater Management

- Revise “BMP’s are not implemented due to concerns of infiltrated stormwater percolating...” to, “BMP’s be tested at each building site and implemented where possible with all surface stormwater management tools, such as rain gardens, bioswales, and woodchips or other strategies to improve soil condition for rainwater absorption and retention.”

Views, Shadows, Air Quality, Noise, and Utility Infrastructure

General Intent & Recommendations

Primary concerns regarding views, shadows, air quality, noise and utility infrastructure include protecting the privacy of adjacent residents; minimizing visual impact of new structures on the surrounding neighborhoods; protecting adjacent residences from air-borne pollutants and noise, particularly as associated with the central utility plant and preserving access to sunlight.

37

It is necessary that the MIMP more clearly identifies what the central utility plant would consist of, how it would operate, when it would operate, and where it would be located. Until that information (or proposed specific restrictions are provided), the DAC cannot sufficiently review and provide recommendations. Some examples of the information required includes the following:

- We require clarification within the MIMP to reconcile inconsistent language that describes a single CUP in some sections, while other sections refer to the possibility of multiple CUP(s).
- We require that projected emissions information and noise level of the CUP be presented in the MIMP and analyzed in the EIS. During meeting 4 with the DAC, it was represented that there would be a study on the CUP: “Study will be conducted to understand air quality impact. Emissions and air quality will depend on generator size, emission system and prevailing winds across the site.” No study has been provided to the DAC.
- We require more information about proposed noise reducing measures and visual screening of all equipment within the CUP yard, including HVAC equipment, generators and associated fuel tanks, and all associated housing, mufflers, piping, ducts, conduit, transformers, electrical panels/load banks, etc. The exhaust of the Emergency Generators shall be directed in a vertical direction versus a horizontal direction. The fuel tanks must be double-walled construction and set within containment sufficient for 100% fuel capacity.
- With the certain types of energy supplied from the CUP to the other Buildings on Campus, it is recommended that these energy sources be run through a means of underground utilidor that could also be part of delivery logistics from one main loading dock area.

38

39

40

41

We also require more information regarding projected upgrades of existing municipal utilities including, but not limited to commercial power, fiber/comm, natural gas, domestic water, sanitary sewer and storm sewer. Nothing was mentioned concerning the existing City utilities in the street to whether or not if these needed to be upgraded with the upgrades and new developments that the hospital wants to do, this could be projected as a square foot impact.

42

RECOMMENDATIONS:

- We recommend that the future structures that are adjacent to the residential properties have window treatments that block the line of vision from the residential properties, the upper sections of glass can be vision panes but the lower sections to obscure the view of the neighboring properties shall be opaque as to let light in but burrs the vision.

43

- We recommend that each proposed project will require a future utility projection be provided, but contingent on individual developments. Some sort of demand calculations had to have been projected. These projections would be handy to know for future impacts. 44
- We recommend that electrical power be mentioned in the utility section regarding increased power demand with upgraded central plant and additional medical facilities. 45
- We recommend that there is communications/data connection mentioned for upgrades on security. 46
- We recommend that WAGD (Waste Anesthetic Gas Disposal) plans, goals, requirements be in both the MIMP and EIS 47
- We recommend that the loop road not run through any setbacks and ideally not run along the Stendall Place property border without a wider setback to buffer the neighborhood from noise, visual, and air quality impacts. 48
- We recommend that loading docks and garbage removal noise is considered, and these activities are located interior and kept away from the perimeters of the property to protect the neighbors from noise-related impacts. 49
- We recommend that the noise of the construction activities be considered with measures such as limiting the use of higher noise equipment, ensuring properly sized mufflers and other silencers and limiting the hours of construction be implemented. 50
- We recommended that a central loading area would be preferred to allow noisy activities to be centralized and dealt with altogether. A minimum of 9 loading docks (berths) seems to be excessive (pg. 83 Development Standards for Loading docks). 51
- Deliveries should be planned for off hours and not peak hours of the hospital services.
- We recommended that the delivery travel path be consolidated with the travel path to and from the Central Utility Plant (CUP). This travel path would be easily isolated/designated for these deliveries of unloading and loading to be separated from the general traffic/pedestrian travel patterns. 52
- We recommend clarification medical gas storage tanks and proposed locations either large tanks at the central utility plant and/or smaller /individual tanks storage. 53
- We require more clarification about the Loading Berth Analysis as follows:
 - It seems that at the existing 18% daily use for 8 loading dock areas are underutilized.
 - The minimum 9 loading berths seems an “assumed “or based on existing amount provided that specific development has yet to be identified.
 - Based on the calculation that one additional loading dock for a total of 9 would equal a 33% utilization.
 - Please provide some further information on these Loading Docks/Loading Zones and Loading Berths.
- We recommend for the added trees to be planted in the “planter strip” or behind the curbs along 115th Street to flourish and remain healthy, that the overhead elevated public utilities be placed underground. The overhead power and communications lines will impede the growth of 55

these trees and as these trees become more mature, they will assist in having utility outages and weather-related events. | 55 Cont.

- We recommend that the utility overhead lines running along Northside of N 115th St. be placed underground for security and as to not interfere with the new tree planting along the planter strip on 115th. | 56

Specific Comments regarding Preliminary Draft EIS

- We recommend that the EIS include a viewpoint from within adjacent neighborhoods. The depictions in the figures are misleading by allowing the background to fade through the 175' building envelope. This creates the false impression that views impacts will not be as bad as they could be if project were actually developed in the proposed envelope. The viewpoint figures should be adjusted so the 175' building envelope is a solid color. | 57

- The EIS does not assess how interior lighting in buildings rising above the tree line will impact surrounding neighborhoods. It also does not assess how night traffic on the proposed loop road will impact adjoining neighborhoods. | 58

- The shadow assessment should be based on full building envelopes unless the proponents want to restrict building locations to those areas identified in the shadow assessment. The figures provided are based upon building designs that the proponent has not committed to. It is also not clear what the heights of the buildings in the shadow analysis are and whether they reflect 175' tall buildings where they are permitted. For example, figure 3.4-18 appears based on a conceptual plan presented during the DAC meeting that identifies the center building height as 173' but the northwestern most buildings at 48'. The figures should identify the building and heights being assessed. The shadow analysis as prepared does not adequately assess impacts of a 175' building on the edge of the zone that could be developed under the alternatives as they have been proposed. | 59

Land Use, Height, Bulk, Scale and Setbacks

General Intent & Recommendations

- Primary concerns regarding land use, height, bulk, scale and setbacks include reducing the visual impact of the buildings on the surrounding neighborhood. We cannot recommend either of the proposed alternates included in the preliminary draft MIMP because neither sufficiently protects the privacy, scale, or character of the adjacent parcels. We believe the following parameters will provide enough opportunity and flexibility for UWMC to expand as described. | 60
- We highly recommend a significant amount of focus on architectural design for perimeter structures. Function will likely be a primary driver, yet special attention to form, aesthetics and design should help to find a middle ground for both the needs of UWMC Northwest and the needs of adjacent neighbors and surrounding community. | 61
- We recommend creative thinking in appearance, possible variable height construction, and thoughtful consideration of tree canopies, greenery and vegetation are all ways to mitigate visual impact. Function will likely be a primary driver when the actual building design takes place, yet special attention to form and aesthetics should likely help find a middle ground for both the needs of UWMC Northwest, the adjacent neighbors and surrounding community. | 62
- The intent around sight lines, exterior lighting, window positioning and placement in order to maintain a sense of privacy is important. | 63
- We recommend that taller buildings be concentrated in the core of campus adjacent to and south of A-wing with lower height buildings be in closer proximity to the adjacent residential communities. | 64
- We recommend that the childcare facility could be located in the northwest corner as well. This would be a low traffic area creating a safe environment for children. | 65
- We recommend the north parking lot by E wing might be a good location for the CUP as it is limited in height. | 66

Specific Comments regarding Preliminary Draft MIMP

Section III - Development Program

Future MIO Height Districts - p.37-42

- Figure 3.7 / 3.12 - We recommend the following changes to the setbacks (see diagram below): | 67
 - 75' on the north half of the west Property Line (adjacent to residential parcels)
 - 75' on the central-east Property Line (where directly adjacent to residential parcels)
 - 20' on the south half of the west Property Line (adjacent to cemetery)
 - 50' on north, northeast and southeast Property Lines (where not directly adjacent to existing residential structures))
 - 20' on the south Property Line
 - Note: Setbacks may include drive-aisles, parking, etc. as long as the existing vegetation remains intact (including trees to the drip line and root structure), except along the west Property Line within the 75'-setback zone. At that location, vehicular traffic must be limited to Fire Lane Only, no other personal or commercial vehicles.
- Figure 3.7-8 / 3.12-13 - We recommend changes to the height limits (see diagram below): | 68
 - Reduce 175' height district to central/south area of campus

- Provide conditioned limits adjacent to residential parcels with existing structures within 20' of property line
- Note: Existing structures within the revised districts may be considered legal nonconforming (“grandfathered”) conditions that may remain in perpetuity as long as no significant building additions or modifications are constructed. Regular maintenance, adaptive reuse, and buildings systems upgrades are acceptable and encouraged, particularly at E-wing.

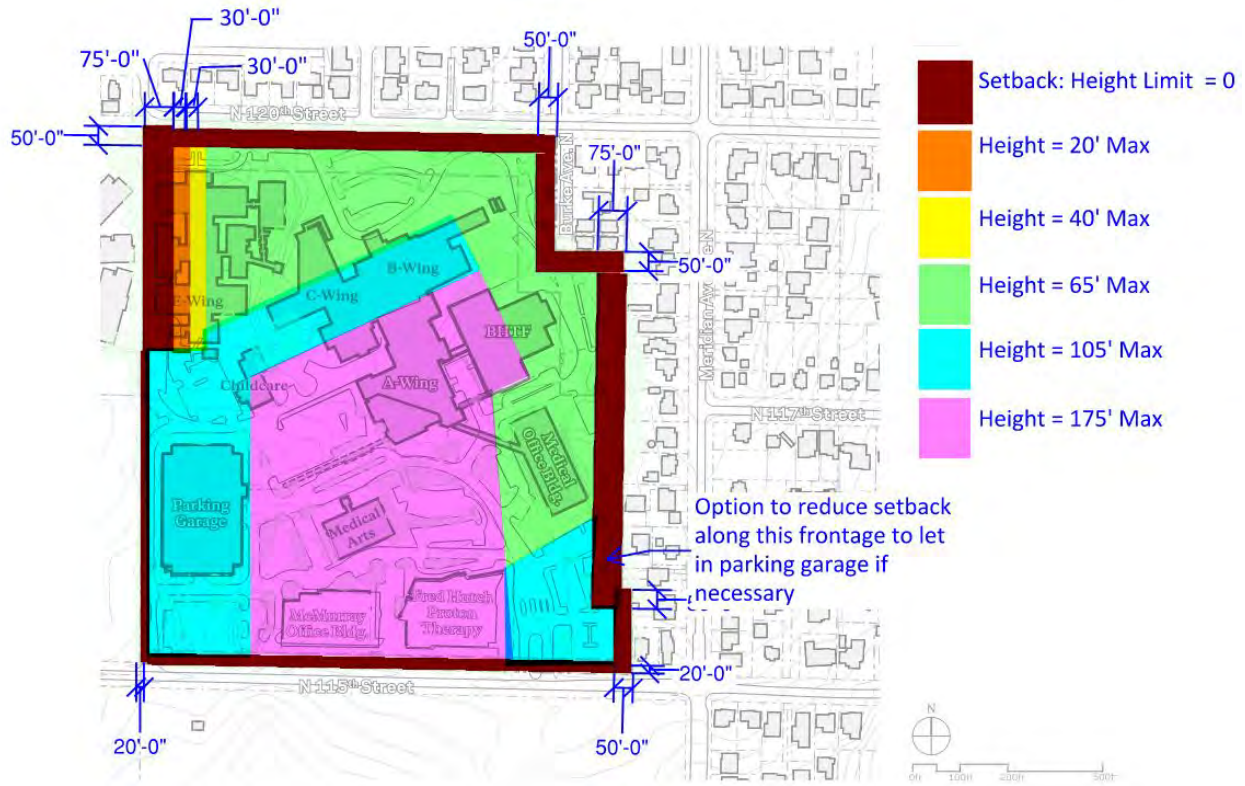

Future Open Space, Landscape and Trees - p.46

- Recommend adding language to this paragraph to limit the “canyon effect” at any given property line. One approach may be to set allowable building frontage at setback to 25% of the total linear distance of any property line adjacent to a residential parcel. For example, say the eastmost property line is 1,000 linear feet in length. Only 250 linear feet of the total setback line may be immediately fronted by a building. Another approach may include prohibiting any building façade to be rectilinear with the property line. Another approach may include setting a solar-angle step-back requirement.

RESPONSE TO LETTER 5a

UWMC-Northwest DAC

1. The comments related to the Development Advisory Committee (DAC) commitment to representing the community is noted. The comments related to Draft *2024 MIMP Update* recommendations are noted and addressed by individual comment responses to this letter.
2. The requested description has been added to the Circulation Section of the *2024 MIMP Update* to indicate that “N 120th Street and Ashworth allow circuitous access to Highway 99 through residential streets.”
3. The following text has been added to Section III/Circulation of the *2024 MIMP Update* to indicate “Campus parking is provided onsite in a 5-story parking garage and multiple surface lots. Patients and visitors pay an hourly rate to park on-campus; UWMC staff also pay to park. Additional, short-term parking is available on the adjacent public rights of way on N 115th Street. UWMC staff are directed not to park off-site.”
4. Comments noted and the UWMC concurs. The cited points have been added to the Transportation Management Program (TMP) section of the *2024 MIMP Update* where the proposed parking supply is identified along with an overview of the TMP and potential strategies.
5. Comments noted. The following responds to the four bullets in this comment.
 - a. The loop drive has not yet been designed or located; no fire lane only restrictions on any potential segment will be placed at this time. However, a 20-foot setback from the property line has been added to the Development Standards section of the *2024 MIMP Update*.
 - b. DAC’s preference for garage locations adjacent to N 115th Street are noted. The potential garage locations are noted accurately until design commences and specific site and/or garage conditions can be further assessed to determine suitability.
 - c. The *2024 MIMP Update* shows N 115th Street as the potential third access. Analysis of the N 120th Street access remains in the EIS but the N 115th Street access is identified as the third access under Final EIS Alternative 3 (Preferred Alternative).
 - d. The cited text remains – proposed use of development is not yet determined.
6. Comment noted. The *2024 MIMP Update* text as stated identifies calibration of parking with development.
7. Bicycle parking is determined by the *2024 MIMP Update* Design Guidance and Development Standards, not citywide code for reasons presented and discussed at the September 5, 2023 DAC meeting. UWMC is committed to providing bicycle parking to meet demand and provide quality facilities to encourage bike ridership.

8. Screening is addressed in the Development Standards section of the *2024 MIMP Update* rather than the cited section to reduce redundancy. The Development Standards Section now indicates “provide for screening to provide visual screening to reasonably obscure a view from adjacent properties to campus utility equipment, support service areas (such as loading berths), and/or surface parking operations.”
9. Comments noted. Parking requirements for the UWMC – Northwest *2024 MIMP Update* are being negotiated with City staff to balance other modes of travel and are included in the Transportation Management Program Section of the *2024 MIMP Update*. The below responds to the four bullets included in the comment.
 - a. No change has been made to the cited section as one instance of “may” refers to potential phasing and timing of parking supply with increased capacity. It may happen before or concurrent with development increases depending on current parking utilization at that time.
 - b. The *2024 MIMP Update* establishes the requirements for the UWMC – Northwest campus as described in the Draft EIS Transportation section and the *2024 MIMP Update* Development Standards.
 - c. This request is inconsistent with City staff directions.
 - d. Comment noted however setbacks are intended to limit building locations only, not other uses or site development. Text has been added to Development Standards (Landscape, b.), “Where new internal drives are developed within building setback areas adjacent to residentially built parcels, the roadway/drive would be located at least 20 feet from the property edge. (This is not applicable in the following areas: existing drives, surface or structured parking areas, where adjacent to rights-of-way.)”
10. Comments noted. The *2024 MIMP Update* and Final EIS Alternative 3 (Preferred Alternative) identifies N 115th Street as the preferred location for a third driveway. The option of an access drive from N 120th Street is not included in the *2024 MIMP Update* or Final EIS Alternative 3 (Preferred Alternative).
11. The cited text related to trip generation has been clarified in the *2024 MIMP Update*. The trip generation assumed both trips to/from the driveways as well as the adjacent on-street (N 115th Street) parking.
12. The *2024 MIMP Update* and Final EIS Alternative 3 (Preferred Alternative) identify N 115th Street as the preferred location for a third driveway. Identification of this access point is intended to address the access/circulation needs of the campus while reducing neighborhood impacts.
13. The *2024 MIMP Update* and Final EIS Alternative 3 (Preferred Alternative) identifies N 115th Street as the preferred location for a third driveway, and expansion of the study area is not warranted; an access drive from N 120th Street is not included in the *2024 MIMP Update* or Final EIS Alternative 3 (Preferred Alternative). Emergency access to the campus is improved

with the additional driveway on N 115th Street. A traffic signal is proposed at the new access, further improving access to the facility, including for emergency vehicles.

14. Specific measures for reducing single-occupant vehicle trips are included in the Transportation Management Program section of the *2024 MIMP Update*. King County Metro currently operates routes that connect to the Northgate Station. Additional connectivity strategies will be reviewed as part of the biannual CTR/TMP review process.
15. The UWMC – Northwest campus does have many mature trees individually planted throughout campus however, it does not constitute a forest. The landscape design intent is stated in the Design Guidance section (Landscape) of the *2024 MIMP Update* as follows: “Access to the natural environment will be provided in different ways throughout the campus.”

UWMC is committed to improving circulation on-campus and that will include additional pedestrian sidewalks for universal accessibility. The interest in a natural trail is noted; further analysis during design may be warranted to determine feasibility and equity of developing a nature trail on campus.
16. The comments regarding open space and landscaping are noted. The Design Guidance (Site Design / Landscape) section of the *2024 MIMP Update* includes language regarding plant material selection, including use of drought tolerant plant materials.
17. The comment regarding aesthetics is noted. See responses to comments 18, 19 and 20 of this letter.
18. Comments noted. UWMC is committed to following best practices and requirements of City Stormwater Manual which includes stormwater management and green infrastructure as noted.
19. UWMC is committed to sustainable design practices and current best practices, including LEED principles and responsible development that is sensitive to the environment. Note that the Living Building Challenge is very difficult to attain for medical center uses. Future design teams will consider best practices and high performing sustainability goals for buildings and landscape design.
20. The perimeter building setbacks are designed to protect existing trees along the campus perimeter. Where possible and in good condition, UWMC intends to maintain and/or replace perimeter tree plantings; see also the Urban Forestry Management Plan (UFMP) for additional detail.
21. Comments regarding tree replacement noted. Note that based on the evolution of best practices over time, tree management and preservation will be guided by the Urban Forestry Management Plan (UFMP), not the *2024 MIMP Update*.

22. Tree management and preservation will be guided by the Urban Forestry Management Plan (UFMP). City staff have provided direction regarding “Tier 1” and “Tier 2” trees per new regulations (rather than “exceptional”). See Section 3 (Updates Subsequent to Issuance of the Draft EIS) of this Final EIS for detail.
23. Use of landscape cloth or fabric is not a MIMP issue and is determined by campus maintenance staff and UWMC best practices.
24. Comment regarding green roofs noted. Text related to green roof design has been added to Architectural Section (Design Guidance) of the *2024 MIMP Update*.
25. Text related to perimeter vegetation has been added to the Landscape Section (Development Standards) of the *2024 MIMP Update*.
26. Comment regarding establishment of a nature trail on campus noted. See response to comment 15 of this letter.
27. The selection of future planting materials (including tree species) will be guided by Design Guidance of the *2024 MIMP Update* and the Urban Forestry Management Plan (UFMP). UWMC seeks to maintain a healthy tree environment and stated canopy goal, which requires a variety of species that are adaptive to climate change and local conditions. See the Landscape Section of the *2024 MIMP Update* for detail.
28. UWMC Grounds crew monitor tree health and follow best practices for tree maintenance, monitoring and removal. The UFMP guidelines will include tree replacement.
29. The comment regarding building height and building modulation in the vicinity of Stendall Place is noted. The *2024 MIMP Update* and Final EIS Alternative 3 (Preferred Alternative) proposes a lower height limit on the northern section of the campus to modulate height across the campus and reduce building heights in the north portion of campus compared to that included in the Draft *2024 MIMP Update* and Draft EIS. See Chapters 2 and 3 of this Final EIS for detail.

The following text has also been added to the *2024 MIMP Update* Design Guidance (Façade Articulation): “Design façade fenestration and openings or other outward features to minimize viewing from campus buildings directly into adjacent residences. Consider use of clerestory windows and/or patterned glass on upper level floors near the campus perimeter, particularly when residential buildings are less than 30 feet from the property line.”

30. Screening, including screening of noise producing features, is addressed in three locations of the *2024 MIMP Update*, including: Design Guidance, Development Standards and Definitions. Walls and landscaping are included options.

Note that Section 3.3 (Environmental Health) of the Draft EIS identifies the following mitigation for individual projects under the *2024 MIMP Update*: “Development projects under the proposed *2024 MIMP Update* that are located in areas that are proximate to noise-sensitive uses could require project-specific coordination with adjacent noise-sensitive users to determine potential noise-related issues associated with development on those sites and could require additional noise analysis and mitigation measures (if necessary).”

31. Text has been added to Design Guidance Section of the *2024 MIMP Update* regarding fencing and landscaping. UWMC – Northwest property line is different in each area and provides a variety of fencing or screening materials. Fencing and screening will be maintained as appropriate for the adjacent uses.
32. The following text has been added to the Design Guidance Section of the *2024 MIMP Update*: “Consider unit pavers and/or permeable paving options where appropriate.”
33. The comments regarding stormwater management and landscaping is noted. See response to comment 18 of this letter.
34. The cited text was edited before the Draft *2024 MIMP Update* was published and reads as follows: “The UWMC – Northwest campus character is best described as a traditional suburban medical center campus with a diverse mix of sprawling buildings set within a landscape of mature trees, grass and clusters of ornamental plantings, with surface parking lots tucked in along the serpentine access drive.”
35. The cited text (in quotes) was added before the Draft *2024 MIMP Update* was published. Additional language was not deemed necessary. UWMC is committed to following best practices and requirements of City Stormwater Manual, including green infrastructure.
36. Comment regarding infiltrating stormwater noted. See response to comment 18 of this letter.
37. Comments noted. To the extent possible, additional information about the central utility plant (CUP) was provided in the Draft *2024 MIMP Update* and Draft EIS as well as DAC presentations; see presentation files for June 26 and September 11, 2023. The CUP siting, design and operations will be reviewed by the Implementation Advisory Committee (IAC) when UWMC pursues that individual project.
38. The text related to providing a single CUP was provided for the published Draft *2024 MIMP Update*.

39. Because the specific location of the CUP is not identified in the *2024 MIMP Update*, additional information regarding potential emissions and noise associated with the CUP is not available. The identification of specific conditions associated with the CUP will occur when the CUP project is in design and permitting, and selection of equipment will be reviewed by the IAC. Any reference to further study refers to during design. Please also refer to response to comment 30 of this letter.
40. Please refer to response to comment 39 of this letter for information regarding noise associated with the CUP and UWMC operations.
41. Comment noted.
42. Connections and/or potential utility system upgrades will be determined during design of all future projects when details on equipment demand and utility requirements are known. Any utility work off-campus or within public rights-of-way would not be considered a square foot impact.
43. Comment noted. See response to comment 29 of this letter.
44. Comment noted. Utility demand calculations will occur during the design of individual projects when systems sizing, utility requirements, and equipment demands are known.
45. As indicated in Section 3.7 (Utilities) of the Draft EIS, development under the *2024 MIMP Update* would require service for telecommunications/data and electricity. The need for extensions and upgrades associated with these utilities would be identified through coordination with the utility providers during the design and permitting process for individual projects. Also see response to comment 44 of this letter.
46. See response to comments 44 and 45 of this letter.
47. UWMC is planning to decommission the existing piped nitrous oxide system. Some inhaled anesthetics have already been eliminated from use in 2023. Protocols are currently being developed with an emphasis on using intravenous anesthetics.
48. The location of the loop drive has not yet been determined. Portions of campus circulation may occur within building setback areas; however, design guidance (Site Design) defines several ways to employ landscape, lighting and screening to help protect campus' neighbors. Note that the *2024 MIMP Update* indicates that the loop road would be located a minimum of 20 feet from abutting residential properties, provision of substantial landscape screening, and posted speed limit of 15 mph. When a specific design of a loop road (or segment of the loop road) is proposed, the University of Washington as SEPA lead agency will conduct project-level SEPA environmental review as needed.

49. Comment noted. Design guidance provided in the *2024 MIMP Update* is intended to help minimize potential visual and auditory impacts of support service areas. The Development Standards section of the 2024 MIMP Update also provides for measures to provide for visual screening to reasonably obscure a view from adjacent properties to campus utility equipment, support service areas (such as loading berths), and/or surface parking operations.
50. As indicated in Section 3.8 (Construction) of the Draft EIS, in addition to compliance with the Seattle Noise Ordinance (SMC 25.08.425) the UWMC has identified additional conditions/considerations that project-specific contractors would follow during construction, including limiting higher noise equipment, utilizing mufflers for stationary equipment, use rubber-tired equipment where possible, and utilize specific scheduling of higher noise activities.
51. Comment noted. Please note that loading berths and loading docks are not the same thing; a loading dock can be comprised of one or more loading berths. The *2024 MIMP Update* represents an increase of one berth over the current conditions. See Appendix E of the *2024 MIMP Update* for loading dock demand analysis.
52. Comments noted. Hospital deliveries occur at all hours and cannot be limited to “off” or “not peak” hours. Location of the CUP and service areas are not determined in the *2024 MIMP Update* but will be consolidated if feasible under individual projects with the intent of providing efficient campus operations.
53. Tanks are addressed in the Infrastructure/Medical Gases Section (Design Guidance) of the *2024 MIMP Update*. Further clarification regarding gas storage tanks is not possible until design of any individual project requiring medical gases.

Section 3.3 (Environmental Health) of the Draft EIS indicates that “Hazardous materials generated and used on campus would continue to be managed in accordance with existing policies/standards established by the University’s Environmental Health and Safety Department, as well as applicable local, state and federal standards/regulations.”

54. The Loading Berth Analysis was summarized in the September 11, 2023 DAC meeting, with the detailed analysis previously reviewed with the DAC members included in Appendix E (Transportation Analysis) of the *2024 MIMP Update*.
55. Comments noted. The Behavioral Health Teaching Facility (BHTF) project included street improvements along N 115th Street and N 120th Street as required by the Seattle Department of Transportation (SDOT), which are being constructed in 2023. No additional improvements to public sidewalks or planting areas are proposed under the *2024 MIMP Update*. Overhead power and communication utilities are not owned by UWMC.

56. Recommendation noted. Overhead power and communication utilities are not owned by UWMC.
57. The comment requesting an additional viewpoint from adjacent residential neighborhoods is noted. Refer to Response to Letter 5 (Stendall Place Homeowners Association) comments 3, 7 and 8 for discussion on viewpoints and view analysis.
58. As indicated in Section 3.4 (Aesthetics/Light & Glare/Shadows) of the Draft EIS, “potential development under the *2024 MIMP Update* would introduce new sources of interior/exterior building lighting associated with new buildings on the campus. The University’s environmental and design review processes will include review of potential factors that could influence lighting conditions, including façade design and building orientation.
59. Comment noted. Refer to Response to Letter 5 (Stendall Place Homeowners Association) comments 3, 7 and 8 for discussion on viewpoints and view analysis.
60. Based on analysis conducted for the Draft EIS, and on comments received from the public and agencies on the Draft *2024 MIMP Update* and Draft EIS, an additional EIS Alternative (Alternative 3) has been identified for this Final EIS. Alternative 3 provides updated building height overlays (a reduction in height in the north portion of the campus) and perimeter building setback areas (an increase to 40-foot building setback where the campus abuts residential properties to the east and west, and abuts the N 120th Street right-of-way to the north), and is considered the Preferred Alternative. Refer to Chapter 2 and 3 of this Final EIS for detail on Alternative 3. Note that the *2024 MIMP Update* reflects the plan presented in Final EIS Alternative 3.
61. Aesthetics are considered important by the UWMC for all campus buildings and will be reviewed by the IAC during project design. All buildings are subject to the Design Guidance and Development Standards included in the *2024 MIMP Update*.
62. Comment noted.
63. Comment noted.
64. Comment noted. See response to comment 60 of this letter.
65. Recommendation for daycare location noted. Precise locations and distribution of uses on-campus are not identified in the *2024 MIMP Update*.
66. Recommendation for CUP location noted. Precise locations and distribution of uses on-campus are not identified in the *2024 MIMP Update*.

67. The *2024 MIMP Update* and Final EIS Alternative 3 (Preferred Alternative) provides updated perimeter building setback areas representing an increase to 40-foot setback where the campus abuts residential properties to the east and west, and where the campus abuts the N 120th Street right-of-way to the north (an increase from Alternatives 1 and 2). Also see response to comment 60 of this letter.
68. Recommendations are appreciated and several have been incorporated into the *2024 MIMP Update* and Final EIS Alternative 3 (Preferred Alternative). However, the heights requested in this comment do not accommodate the 1.6 million square feet projected for meeting healthcare demand while maintaining full healthcare services and operations or existing land leases. See the *2024 MIMP Update* and Chapters 2 and 3 of this Final EIS for detail.
69. Recommendations noted. Please see Chapter 2 of this Final EIS for discussion on building setbacks and height limits in proposed Alternative 3.

From: Dan A. <danthecoug@gmail.com>
Sent: Thursday, September 21, 2023 7:43 PM
To: deborah.Juarez@seattle.gov; NorthwestMIMP@uw.edu
Subject: UW Medicine Entrance and Access

Hello,

My family and I live on 121st St in north Seattle. I and MANY of our neighbors are extremely upset that the UW hospital intends on having an entrance at N. 120th St. This would greatly disturb our homes, not to mention the constant homeless encampments and several motor-homes parked there now. We will not take to this quietly. The community of 120st St and 121st St meet every last Thursday of the month to socialize and discuss community affairs. We feel that our concerns are not being heard, which is evidenced by the constant motor-homes parked and homeless encampments the city allows along 120th St. We are extremely upset and will mobilize collectively and take action.

1
2

-Dylan

RESPONSE TO LETTER 6

Anther, Dylan

1. Comment noted. The *2024 MIMP Update* and Final EIS Alternative 3 (Preferred Alternative) identifies N 115th Street as the proposed location for a third driveway.
2. The comment regarding motor-home parking and encampments along the public N 120th Street right-of-way is noted. UWMC is as concerned with this city issue. On more than one occasion the site has been cleared of encampments as it has reached its place in the queue of encampments requested to be cleared. At the time of writing, construction of curb, gutter and sidewalk along N 120th Street was underway which will also remove the space that was available for encampment.

From: [Kashi Arora](#)
To: NorthwestMIMP@uw.edu
Subject: Public Comment RE: MIMP
Date: Tuesday, October 3, 2023 7:32:05 PM

Hello,

My name is Kashi Arora and I live in the neighborhood behind Northwest Hospital (behind 120th). I am writing to submit public comment regarding UWMC Northwest's Major Institution Master Plan. First, I am glad to see UWMC strategically planning for the needs of our region and community in the coming decades. I am also excited about the opening of the Behavioral Health Teaching Facility and appreciate UWMC's focus on behavioral health as a priority.

1

Regarding the specifics of the plan, I have a few comments/requests for the planning committees to consider:

1. Please do not have an access road on North 120th Street. This would change the neighborhood feel and could significantly impact traffic patterns. There are multiple points of access via 115th Street to serve the campus.
2. Regarding setbacks, the current setback range is 120' while the proposed is only 20 or 30' - this is a significant change. A setback of 40' or 50' seems like a reasonable compromise while still allowing UWMC the space to expand as needed.
3. The proposed changes to height limits of buildings are also significant. The highest proposed height limit is 175', which is a very tall building especially in this community. Please restrict the 175' height limit to the southern 2/3 of the property so there are ways to ensure the campus can meet the needs of its patients and not dramatically change the neighborhood for the community.

2

3

4

Thank you for considering these requests and for the work you're doing to update our community's hospital so we all have the medical services we need!

Let me know if you have any questions or concerns.

With appreciation,

Kashi

--

Kashi Arora
arora.kashi@gmail.com
(425) 354-8896

RESPONSE TO LETTER 7

Arora, Kashi

1. Thank you, your comment is noted.
2. The 2024 *MIMP Update* and Final EIS Alternative 3 (Preferred Alternative) identifies N 115th Street as the preferred location for a third driveway. Please see Chapter 2 and Chapter 3 of this Final EIS for discussion on Alternative 3.
3. Please see Chapter 2 and Chapter 3 of this Final EIS for discussion on Alternative 3 (Preferred Alternative) that proposes an increase to a 40-foot building setback where the campus abuts residential properties to the east and west, and where the campus abuts the N 120th Street right-of-way to the north.
4. Please see Chapter 2 and Chapter 3 of this Final EIS for discussion on Alternative 3 that proposes a reduction in building height in the north portion of the campus.

From: Judy Baskey <mizzhudi13@gmail.com>
Sent: Friday, September 22, 2023 12:28 PM
To: NorthwestMIMP@uw.edu
Subject: Public Comment

>> This is a public comment from the Moores at 11931 Stendall Dr N. Seattle WA 98133 in regards to the new plan of UW Medical Center Northwest Campus.

>>

>> We strongly recommend the following:

>> 1. ENTRANCE

>> No access road on 120th Street.

>>

>> 2. LAND USE PLANS AND POLICIES

>> * A 40-50ft set back for the North Side

>> * A 40-50ft set back for the North 1/2 of the West Side

>> * A 40-50ft set back for the East side

>>

>> 3. HEIGHT LIMITS

>> A 175ft height limit to be restricted to the southern 2/3 of the property area.

>>

>> Thank you,

>> Dr. Gene and Judy Moore

>> 11931 Stendall Drive N

>> Sea. le, WA 98133

>>

Sent from my iPhone Sent from my iPad

| 1

| 2

| 3

RESPONSE TO LETTER 8

Baskey, Judy

1. Comment noted. The *2024 MIMP Update* and Final EIS Alternative 3 (Preferred Alternative) identifies N 115th Street as the preferred location for a third driveway.
2. Please see Chapter 2 and Chapter 3 of this Final EIS for discussion on Alternative 3 (Preferred Alternative) that proposes an increase to a 40-foot building setback where the campus abuts residential properties to the east and west, and where the campus abuts the N 120th Street right-of-way to the north.
3. Please see Chapter 2 and Chapter 3 of this Final EIS for discussion on Alternative 3 that proposes a reduction in building height in the north portion of the campus.

From: [DONNA D. BELL](#)
To: NorthwestMIMP@uw.edu
Subject: Draft Environmental Impact Statement (DEIS)
Date: Thursday, October 5, 2023 3:56:58 PM

To whom it may concern:

City of Seattle Land Use Code: "BALANCE a major institutions ability to change and the public benefit derived from change with the need to PROTECT THE LIVABILITY AND VITALITY OF ADJACENT NEIGHBORHOODS."

I have been a resident of Stendall Place Townhomes, located on the west border of UWMC-Northwest campus, for 40 years. I endorse the recommendations submitted by the UWMC-Northwest Development Advisory Committee (DAC) related to the UWMC-Northwest Major Institution Master Plan (MIMP). Please keep in mind the purpose of the Seattle Land Use Code stressing the necessity "to Protect The Livability and Vitality of Adjacent Neighborhoods."

Traffic: A few years ago I witnessed an elderly woman hit by a car at the intersection of Meridian Avenue North and N. 115th St. Seriously injured, three of us monitored her health until medical aid arrived. Over the years I have witnessed an increase in traffic branching out from N. 115th St. onto residential streets including N. 120th St. Increasingly, drivers are using residential streets as short cuts to access the Northgate Station Light Rail and when Aurora Avenue is congested, often speeding. The safety of seniors, children, joggers, dog walkers and others in our neighborhood will be further impacted if N. 120th becomes a major entry/exit for all types of transportation to UWMC-N. Air quality will be compromised in an area utilized for exercise and connection to nature. The overall social stability and safety of the neighborhood would be at risk.

Building Set Backs and Building Heights: Building set backs and heights should not block natural light; increase glare from campus indoor or outdoor lighting; eliminate views; decrease privacy; lessen aesthetics; or, increase noise level for residents living on borders of the UWMC-N campus. Disregarding the quality of residents' properties threatens decrease in future real estate values.

Just as UWMC-N has the goal to "ensure the community understands the project vision", the community has the goal that UWMC-N understands how the Major Institution Master Plan (MIMP) could impact the community's quality of life, including property value.

Thank you for including my comments regarding the UWMC-N MIMP.

Sincerely,
Donna D. Bell
11713 Stendall PI N
Seattle, WA 98133
206-713-9626
dd.bell@comcast.net

1

2

3

4

5

RESPONSE TO LETTER 9

Bell, Donna

1. The UWMC is grateful for the DAC members' participation and guidance throughout this process. DAC comments on the preliminary draft documents influenced the published versions and many –but not all– changes were made in the Draft *2024 MIMP Update* and Draft EIS. As the DAC was informed, this is an iterative process and comments from the general public and the DAC will continue to impact the development of the MIMP.
2. The traffic and safety impacts associated with the optional access from N 120th Street were evaluated in the EIS. The *2024 MIMP Update* and Final EIS identifies N 115th Street as the preferred location for a third driveway in Alternative 3. Please refer to Chapter 2 and 3 of this Final EIS.
3. The comments related to air quality and safety impacts associated with the optional access from N 120th Street are noted.

Section 3.2 (Air Quality/GHG Emissions) of the Draft EIS indicates that a potential new driveway access from N 120th Street would introduce vehicular traffic in the area to the north of campus that would result in associated vehicular air quality emissions which could be noticeable for residences in this area. Section 3.6 (Transportation) of the Draft EIS includes analysis of traffic operations with the optional driveway access from N 120th Street and indicates that this access would operate at LOS A (indicating free-flowing traffic with no congestion) with no identified safety issues. Note that the *2024 MIMP Update* identifies N 115th Street as the preferred location for a third driveway as reflected in Alternative 3 added for this Final EIS.

4. The comments regarding proposed building heights affecting views, privacy, and access to light are noted. Refer to Response to Letter 5 (Stendall Homeowners Association) comments 3, 7, 8 and 9 for discussion on views and shadows.

Section 3.1 (Land Use) of the Draft EIS indicates that proposed building heights would allow for taller buildings compared to the majority of building currently on the UWMC-Northwest campus and in the immediately surrounding area. Proposed building heights in proximity to the east and west edges of campus would result in an increase in potential building heights in proximity to adjacent residential neighborhoods with one- to three-story buildings to the immediate east and west of campus. Please see Chapters 2 and 3 of this Final EIS for discussion on Alternative 3 (Preferred Alternative), including proposed perimeter building setbacks and building height overlays.

5. Comment noted. The potential for environmental impact associated with the proposed *2024 MIMP Update* is the reason for the preparation of the EIS analysis. Refer to Response to Letter 5 (Stendall Place Homeowners Association) for discussion regarding environmental analysis related to Stendall Place.

UWMC-Northwest
Major Institution Master Plan Update

Draft EIS Comment Form

UWMC invites your comments on the Draft Major Institution Master Plan Update and Draft Environmental Impact Statement. Written comments may be mailed to Julie Blakeslee, Univ. of Washington, Box 352205, Seattle, WA 98195-2205 or emailed to NorthwestMIMP@uw.edu.

Contact Information

Please Print

Name: Melanie Bjork Affiliation, if any: resident of Stendall Pl.

Address: 11708 Stendall Dr N

City: Seattle State: WA Zip: 98133

E-mail address: melaniepb@hotmail.com

Completing this form will automatically add you to the mailing list. If you prefer not to be on the mailing list, please check the box to the right. I do not wish to be on the project mailing list.

Please print your comment below:

I appreciate the service the UW hospital provides to the neighborhood and community at large. I've been a beneficiary of excellent emergency care which reversed a stroke. ~~Thank you~~
That said, as a resident of the neighborhood, there are some concerns.

1) An access on N. 120th St. is not acceptable. This is a side road, with extensive east traffic and insufficient width to accommodate increased travel. The neighbors across from the hospital would be negatively impacted 24/7. Finally, the transportation maps at the presentation tonight project increased backups on 115th in 2 scenarios involving the 120th entrance.

2) My preference ~~right now~~ regarding setbacks and building ~~height~~ would be for a wider setback.

Comments must be received or postmarked by October 5, 2023

along the Stendall Pl. fence. I would prefer to accept more ^{building} height with a wider setback and no road along the fence. I don't live on that over

1

2

3

4

side of the Stendall property, but I do have an active driveway along (across) my back fence, and it is disruptive enough (another condo association's entrance) to imagine the impact of a hospital road. A higher building further from the fence would seem more acceptable to this one Stendall Resident.

Melanie Bjork

4 Cont.

5

RESPONSE TO LETTER 10

Bjork, Melanie

1. The traffic and safety impacts associated with the optional access from N 120th Street were evaluated in the Draft EIS. The *2024 MIMP Update* and Final EIS Alternative 3 (Preferred Alternative) identifies N 115th Street as the preferred location for a third driveway. Please refer to Chapter 2 and 3 of this Final EIS for discussion on Alternative 3 (Preferred Alternative).
2. Comment noted.
3. Based on analysis conducted for the Draft EIS, and on comments received from the public and agencies on the Draft *2024 MIMP Update* and Draft EIS, an additional EIS Alternative (Alternative 3) has been identified for this Final EIS. Alternative 3 provides updated building height overlays (a reduction in height in the north portion of the campus) and perimeter building setback areas (an increase to 40-foot building setback where the campus abuts residential properties to the east and west, and where the campus abuts the N 120th Street right-of-way to the north), and is considered the Preferred Alternative. Refer to Chapter 2 and 3 of this Final EIS for detail on Alternative 3.
4. Location of the loop drive has not yet been determined. Portions of campus circulation may occur within building setback areas however design guidance (Site Design and Development Standards) defines several ways to employ landscape, lighting and screening to help protect campus' neighbors.
5. Comment noted. See response to comment 3 of this letter.

10/3/2023

UWMC NORTHWEST HOSIPTAL MASTER PLAN

To Whom it concerns,

Regarding Setback Alternative 2, to reduce the encroachment on the residential areas, it seems like minimal setback from N 115th Street which is not adjacent to residential zones would be optimal allowing some relief from the setbacks in other areas next to residential zones and N 120th Street.

1

Regarding Height Zones Alternative 2, to reduce the encroachment on the residential areas, it seems like 105 foot zones along N 115th Street and around the parking garage zone and around the Medical Office building (not sure why it is drawn as wider around building 7) would be preferrable with 65 foot zones adjacent to residential zones and N 120th Street.

2

Regarding Transportation Entrances, adding an access road to N 120th Street is not a welcome addition to the neighborhood as it will drive a large amount of traffic to this location and along the quieter connector streets. That route is a preferred route to James Baldwin Elementary School as well as a connector to head north to the Ingram Highschool so it would be a disruption to the quiet community streets.

3

SINCERELY,

WALTER BLOMBERG

RESPONSE TO LETTER 11

Blomberg, Walter

1. Based on analysis conducted for the Draft EIS, and on comments received from the public and agencies on the Draft *2024 MIMP Update* and Draft EIS, an additional EIS Alternative (Alternative 3) has been identified for this Final EIS. Alternative 3 provides updated building height overlays (a reduction in the north portion of the campus) and perimeter building setback areas (an increase to 40-foot building setback where the campus abuts residential properties to the east and west, and where the campus abuts the N 120th Street right-of-way to the north), and is considered the Preferred Alternative. Refer to Chapters 2 and 3 of this Final EIS for detail on Alternative 3.
2. Comment noted. See response to comment 1 of this letter.
3. The *2024 MIMP Update* and Final EIS Alternative 3 (Preferred Alternative) identifies N 115th Street as the preferred location for a third driveway. Refer to Chapters 2 and 3 of this Final EIS for detail on Alternative 3.

UWMC-Northwest
Major Institution Master Plan Update

Draft EIS Comment Form

UWMC invites your comments on the Draft Major Institution Master Plan Update and Draft Environmental Impact Statement. Written comments may be mailed to Julie Blakeslee, Univ. of Washington, Box 352205, Seattle, WA 98195-2205 or emailed to NorthwestMIMP@uw.edu.

Contact Information

Please Print

Name: Patricia Breen Affiliation, if any: neighbor

Address: 11901 Stendall Pl N

City: Seattle State: WA Zip: 98133

E-mail address: breenpa@gmail.com

Completing this form will automatically add you to the mailing list. If you prefer not to be on the mailing list, please check the box to the right. I do not wish to be on the project mailing list.

Please print your comment below:

Prefer Alternative 2 for heights + setback

1

120th St is a poor choice for new auto access.

with no state walks ① The street is narrow, ② it is in a densely populated neighbor hood, ③ Cars would be forced to travel around several streets to get back to a through deadend

2

street, ④ The access point is out of the way and would likely be used less frequently.

⑤ 115th St is better for traffic.

Comments must be received or postmarked by October 5, 2023

RESPONSE TO LETTER 12

Breen, Patricia

1. Support for Alternative 2 noted.
2. The *2024 MIMP Update* and Final EIS Alternative 3 (Preferred Alternative) identifies N 115th Street as the preferred location for a third driveway. Please refer to Chapters 2 and 3 of this Final EIS for detail on Alternative 3.

From: Kimberley Chastain <kimberleychastain@gmail.com>
Sent: Monday, October 2, 2023 3:02 PM
To: NorthwestMIMP@uw.edu
Subject: Comments on UWMC NW Hospital Master Plan

To whom may concern,

As residents and homeowners in the Haller Lake neighborhood, we would appreciate you taking into consideration our following concerns regarding the Major Institution Master Plan for UWMC NW Hospital.

My husband and I regularly walk through our neighborhood for leisure and exercise and take family members and pets on walks as well. We are concerned about the additional entrance being proposed on North 120th street as being a significant change to the fact that we have what is considered a 'closed-loop neighborhood' at this time, and for safety and traffic reasons, we wish for it to remain that way.

Our other main concern at this time is the building height limit increase up to a max of 175 feet, which would be a towering shadow over many of the homes near the edge of the property. We respectfully request that any tall structures are restricted to the Southern two thirds of the proposed building area.

We, the neighbors, supporters of UW Medicine, health care workers, homeowners and good citizens, thank you for your serious consideration.

Sincerely,

Kimberley Chastain, BS, MS, ARNP
and Blair Ducote
12241 Densmore Ave N
Seattle WA 98133

1
2

RESPONSE TO LETTER 13

Chastain, Kimberly

1. Comment noted. The *2024 MIMP Update* and Final EIS Alternative 3 (Preferred Alternative) identifies N 115th Street as the preferred location for a third driveway. Refer to Chapters 2 and 3 of this Final EIS for discussion on Alternative 3.
2. Based on analysis conducted for the Draft EIS, and on comments received from the public and agencies on the Draft *2024 MIMP Update* and Draft EIS, an additional EIS Alternative (Alternative 3) has been identified for this Final EIS. Alternative 3 provides updated building height overlays (a reduction in height in the north portion of the campus) and perimeter building setback areas (an increase to 40-foot building setback where the campus abuts residential properties to the east and west, and where the campus abuts the N 120th Street right-of-way to the north), and is considered the Preferred Alternative. Refer to Chapters 2 and 3 of this Final EIS for detail on Alternative 3.

From: Ankur Dhoot <ankurdhoot97@gmail.com>
Sent: Monday, October 2, 2023 8:04 PM
To: NorthwestMIMP@uw.edu
Subject: Bicycle / Micromobility Access

Hello,

I was writing to give feedback about bicycle and micro mobility access to UWMC - Northwest.

I would encourage the Master Plan to ensure there are safe bicycle / micro mobility routes to the campus as well as through the campus. There should also be adequate bicycle and micro mobility device parking.

The access and circulation portion of the Master Plan places an emphasis on pedestrian, bike, transit trips to the hospital, which I highly encourage. However, the area is currently lacking safe pedestrian / bike routes. I encourage the hospital to advocate for improved active transportation routes in the area.

Thanks,
Ankur

1

RESPONSE TO LETTER 14

Dhoot, Ankur

1. As part of the future design review process for actual buildings, provisions for bike parking, micro-mobility, and pedestrians will be addressed. The assessment of pedestrian facilities was updated in the Final EIS to include the character and nature of the routes in the vicinity of the campus. At the time of writing, construction of curb, gutter, and sidewalk along N 120th Street adjacent to the UWMC-Northwest property was underway that will improve safe pedestrian and bike routes along N 120th Street. UWMC will continue to be a supporting community member for safe streets.

UWMC-Northwest
Major Institution Master Plan Update

Draft EIS Comment Form

UWMC invites your comments on the Draft Major Institution Master Plan Update and Draft Environmental Impact Statement. Written comments may be mailed to Julie Blakeslee, Univ. of Washington, Box 352205, Seattle, WA 98195-2205 or emailed to NorthwestMIMP@uw.edu.

Contact Information

Please Print

Name: Doug Donohue Affiliation, if any: _____

Address: 11814 Stendall Pl N

City: Seattle State: WA Zip: 98133

E-mail address: dougbd@comcast.net

Completing this form will automatically add you to the mailing list. If you prefer not to be on the mailing list, please check the box to the right. I do not wish to be on the project mailing list.

Please print your comment below:

This change will permently Remove our access to daylight. We live adjacent to the West fence line. We think that it would be simple and cost effective to accomodate better access to sunlight.

1

Also we are concerned about the noise when an access road is put in by the West fence line.

2

Comments must be received or postmarked by October 5, 2023

RESPONSE TO LETTER 15

Donohue, Doug

1. The comment regarding impact to access to daylight is noted. Refer to Response to Letter 5 (Stendall Place Homeowners Association), comments 3, 7, 8 and 9 for discussion on the shadow analysis conducted for the Draft EIS.
2. Based on analysis conducted for the Draft EIS, and on comments received from the public and agencies on the Draft *2024 MIMP Update* and Draft EIS, an additional EIS Alternative (Alternative 3) has been identified for this Final EIS. Alternative 3 provides updated building height overlays (a reduction in height in the north portion of the campus) and perimeter building setback areas (an increase to 40-foot building setback where the campus abuts residential properties to the east and west, and where the campus abuts the N 120th Street right-of-way to the north), and is considered the Preferred Alternative. Refer to Chapters 2 and 3 of this Final EIS for detail on Alternative 3.

October 4, 2023

Julie Blakeslee
Project Manager
University of Washington, Box 352205
Seattle, WA 98195

RE: UWMC – Northwest Major Institution Master Plan: SEPA Comments

Dear Ms. Blakeslee,

As a resident and homeowner in the Haller Lake neighborhood, along 120th street in the single family residential neighborhood, I am writing to provide my comments and concerns associated with the UW Medical Center – Northwest Draft Major Institution Master Plan (MIMP). After reviewing the drafted MIMP, the below

Future Campus Circulation, Parking and Wayfinding – N 120th Street Access Point

The proposed access point on 120th street is one that I am **VERY opposed to**. N 120th Street is currently a closed loop neighborhood that keeps our quiet streets from being utilized as a main thoroughfare. I purchased my home, located on 120th and Ashworth Ave N, because of the limited amount of traffic that comes through the neighborhood. My family and I walk down these neighborhood streets daily and enjoy/feel safe with the minimal traffic that currently drives past us on these trips. An added amount of cars would minimize this feeling of safety and add a significant amount of noise to these currently quiet streets.

1

The other access point being considered on N 115th Street is located on the same street as the current access points and 115th street is already planned to be modified to accommodate an increase in traffic. This access point is **preferred**.

Land Use Plans & Policies

- Setbacks: I recommend a 40' or 50' setback for the north side right-of-way, the north half of the west side abutting parcels and the east side along rights of way & abutting parcels. A 40' or 50' setback along the N 120th Street right of way is still significantly less than the current 120' setback but still provides a barrier between the campus and our community.
- Height Limits: The change of the MIO heights from 37'/50'/105' to the proposed 65'/175' could significantly impact our neighborhood. A 175' building would be the largest anywhere in North Seattle and drastically changes our neighborhood. I recommend that the 175' height limit be restricted to the southern 2/3 of the proposed 175' area noted in Alternative 2 - Figure 3.12.

2

3

I appreciate UWMC, DON and the DAC for taking into consideration the comments and concerns I have outlined above, all of which will have major impacts to our community for many years to come.

Thank you,

Kara Drechsler
Haller Lake Community Homeowner
drechsk@icloud.com

RESPONSE TO LETTER 16

Drechsler, Kara

1. The *2024 MIMP Update* and Final EIS Alternative 3 (Preferred Alternative) identifies N 115th Street as the preferred location for a third driveway. See Chapters 2 and 3 of this Final EIS for detail on Alternative 3.
2. Based on analysis conducted for the Draft EIS, and on comments received from the public and agencies on the Draft *2024 MIMP Update* and Draft EIS, an additional EIS Alternative (Alternative 3) has been identified for this Final EIS. Alternative 3 provides updated building height overlays (a reduction in height in the north portion of the campus) and perimeter building setback areas (an increase to 40-foot building setback where the campus abuts residential properties to the east and west, and where the campus abuts the N 120th Street right-of-way to the north), and is considered the Preferred Alternative. Refer to Chapters 2 and 3 of this Final EIS for detail on Alternative 3.
3. See response to comment 2 of this letter.

From: Warner Edwards <warnerjedwards@gmail.com>
Sent: Tuesday, October 3, 2023 7:44 PM
To: northwestmimp@uw.edu
Subject: NW Hospital Haller Lake Citizen Concerns

To whom it may concern,

I hope this message finds you well. I am writing to express my deep concerns about the proposed changes to the hospital development plan, specifically regarding the additional access road on 120th Street, the property line setback, and the height restrictions.

Firstly, I strongly oppose the idea of adding an additional access road to the hospital on 120th Street. Such a road would not only disrupt the tranquility of our neighborhood but could potentially pose serious safety risks. The increased traffic and noise associated with an additional road would be detrimental to the peaceful environment we value in our community.

1

Secondly, I would like to request that the property line setback be set at either 40 or 50 feet, rather than the proposed 120 feet. A greater setback would not only preserve the aesthetic appeal of our neighborhood but also provide a buffer zone between the hospital and the residential areas, ensuring the privacy and well-being of the residents.

2

Lastly, I would like to see a restricted height limit of 175 feet for the southern two-thirds of the property area. This restriction is necessary to maintain the character of our neighborhood and prevent any negative impact on the quality of life for those living nearby. It is essential that the hospital development remains in harmony with the surrounding residential properties.

3

I kindly request that you consider these concerns and requests seriously during the decision-making process for the hospital development. Our neighborhood's well-being and the peaceful coexistence of the hospital and residential areas are of utmost importance to us.

4

Thank you for your attention to this matter. I look forward to hearing from you soon and hope that our community's interests will be taken into account as this project progresses.

Sincerely,

Warner Edwards 1318 N 121st, Seattle, WA, 98133

RESPONSE TO LETTER 17

Edwards, Warner

1. The comment opposing a third access drive from N 120th Street is noted. Please note that Alternative 3 (Preferred Alternative) identifies the third access driveway as being from N 115th Street. Refer to Chapters 2 and 3 of this Final EIS for discussion on Alternative 3.
2. Based on analysis conducted for the Draft EIS, and on comments received from the public and agencies on the Draft *2024 MIMP Update* and Draft EIS, an additional EIS Alternative (Alternative 3) has been identified for this Final EIS. Alternative 3 provides updated building height overlays (a reduction in height in the north portion of the campus) and perimeter building setback areas (an increase to 40-foot building setback where the campus abuts residential properties to the east and west, and where the campus abuts the N 120th Street right-of-way to the north), and is considered the Preferred Alternative. Refer to Chapters 2 and 3 of this Final EIS for detail on Alternative 3.
3. Additional height is needed beyond the southern two thirds of the site to accommodate the total building development and phasing requirements to meet health care demands. Please review an added alternative (Alternative 3) that includes step-down heights where possible; see Chapters 2 and 3 of this Final EIS.
4. Comments noted.

From: [Shawna Feiling](#)
To: [Juarez, Debora](#)
Subject: Strongly Opposed to a New Entrance to NW Hospital on N 120th St
Date: Monday, September 25, 2023 12:56:39 PM

CAUTION: External Email

Hello Debora,

This is the first time I have ever contacted our Council Person. I am reaching out because I am a homeowner on North 120th Street and I have learned the NW Hospital would like to put an entrance on N 120th Street. This would have a large negative impact on the street and the neighborhood. This street is a smaller street with no sidewalks. Increased traffic will increase the safety risks to the local community. There are several children that live in the area and a neighborhood school down the street. We are already experiencing increased parking issues and safety concerns with the new townhouse developments being built on the street. I strongly oppose an entrance to NW Hospital on n 120th street. Please let me know what avenues I can pursue to stop the entrance.

1

Thanks,

Shawna Feiling
shawnafeiling@gmail.com

RESPONSE TO LETTER 18

Feiling, Shawna

1. The comment opposing the third access drive from N 120th Street is noted. Please note that Final EIS Alternative 3 (Preferred Alternative) identifies the third access drive as being from N 115th Street. Refer to Chapters 2 and 3 of this Final EIS for detail.

From: [Lorna Follis](#)
To: NorthwestMIMP@uw.edu
Subject: NW Hospital Master Plan Update
Date: Thursday, October 5, 2023 11:39:24 AM

I am a resident of Stendall Place, the 67-unit planned community immediately next door to NW Hospital on the northwest side of the hospital campus. I am the first residence on the east side of Stendall Place North. The property behind my home abuts the maintenance road entrance/fence off N. 120th street.

While I support and understand the need for a major update to NW Hospital, I also support the concerns noted in the community DAC report. It is my understanding that all of those concerns have fallen on deaf ears. I urge Master Planners to re-think issues around setbacks, height limits, and a new hospital entrance off 120th Street per notations in the DAC report. NW Hospital has been a good neighbor and I would hope that relationship with their surrounding community continues.

Lorna Follis
11912 Stendall Place N., Unit #1
Seattle, WA 98133
206.719.3109
lornafollis@outlook.com

RESPONSE TO LETTER 19

Follis, Lorna

1. Comments noted. The UWMC highly values and has listened to input from the DAC and the public. Based on analysis conducted for the Draft EIS, and on comments received from the public and agencies on the Draft *2024 MIMP Update* and Draft EIS, an additional EIS Alternative (Alternative 3) has been identified for this Final EIS. Alternative 3 provides updated building height overlays and perimeter building setback areas, and is considered the Preferred Alternative. Refer to Chapters 2 and 3 of this Final EIS for details on Alternative 3.

From: Helga Forhan <hms545@yahoo.com>
Sent: Thursday, September 21, 2023 12:55 PM
To: NorthwestMIMP@uw.edu
Subject: Northwest Master Plan Input

Hello,
I live in Stendall Place and my backyard abuts your fence. I have a few issues with your proposed master plan. | 1
Setback in that area should be at least 40-50 feet, and the height should be kept to a minimum, because the people | 2
living right along the fence will never get sunshine, but live in shade and diminished light. During evening/ night hours it |
will be just the opposite, and we will have light and noise pollution. I think your taller buildings should be abutting the |
cemetery, and the parking garage and lower buildings could be built by the fence line with an 40-50 feet setback.

I am opposed to a second entrance to the hospital off 120th St, as such a tiny street is unable to support all the extra | 3
traffic.

Respectfully
Helga Forhan
11802 Stendall Pl N
Sea. le, Wa 98133

Sent from my iPad

RESPONSE TO LETTER 20

Forhan, Helga

1. Based on analysis conducted for the Draft EIS, and on comments received from the public and agencies on the Draft *2024 MIMP Update* and Draft EIS, an additional EIS Alternative (Alternative 3) has been identified for this Final EIS. Alternative 3 provides updated building height overlays (a reduction in height in the north portion of the campus) and perimeter building setback areas (an increase to 40-foot building setback where the campus abuts residential properties to the east and west, and where the campus abuts the N 120th Street right-of-way to the north), and is considered the Preferred Alternative. Refer to Chapters 2 and 3 of this Final EIS for detail on Alternative 3.
2. The comment regarding shade and light is noted. Refer to Response to Letter 5 (Stendall Place Homeowners Association), comments 3, 7, 8 and 9 for discussion on the shadow analysis conducted for the Draft EIS.
3. The *2024 MIMP Update* and Final EIS identifies N 115th Street as the preferred location for a third driveway in Alternative 3. Refer to Chapters 2 and 3 of this Final EIS for detail.

From: [LM G](#)
To: NorthwestMIMP@uw.edu
Subject: Bike access to campus
Date: Tuesday, October 3, 2023 8:56:20 PM

Hello,

I'm writing to advocate for as much bicycle access as possible on the new campus. Given the opportunity patients, and staff will use bikes to get there more than you might think. It would also be hugely beneficial to the neighborhood the hospital serves. As someone who worked in a Seattle emergency department for decades and experienced ridiculous burnout, being able to bike to work extended my working life by several years. Especially with the proliferation of e-bikes, given the opportunity UW residents might choose to bike to rotations as well.

1

Thanks for hearing my pitch for healthy transportation options.

Lisa Garbrick, MD

RESPONSE TO LETTER 21

Garbrick, Lisa

1. Bicycle access support is noted. The UWMC is committed to improving campus circulation for all modes of transportation as projects are developed. UWMC will continue to be a supporting community member for safe streets.

From: [STEVE & MARY GILES](#)
To: Northwestmimp@uw.edu
Subject: Uwmc materplan
Date: Wednesday, October 4, 2023 1:20:30 PM

Hello,

I've been a Haller Lake neighborhood resident for 33 years. We've enjoyed the quiet and low traffic traveled residential Densmore Ave side of the hospital.

Our recommendations for master plan process for what it's worth;

Entrance access on 120th Street would greatly impose on the residential neighborhood traffic and parking. We would vote no on that. | 1

Setbacks preferred on north side, 40-50 feet | 2

Thank you,

Steve Giles

RESPONSE TO LETTER 22

Giles, Steve and Mary

1. Comment noted. The *2024 MIMP Update* and Final EIS Alternative 3 (Preferred Alternative) identifies N 115th Street as the preferred location for a third driveway. Please refer to Chapters 2 and 3 of this Final EIS for detail.
2. Based on analysis conducted for the Draft EIS, and on comments received from the public and agencies on the Draft *2024 MIMP Update* and Draft EIS, an additional EIS Alternative (Alternative 3) has been identified for this Final EIS. Alternative 3 provides updated building height overlays (a reduction in height in the north portion of the campus) and perimeter building setback areas (an increase to 40-foot building setback where the campus abuts residential properties to the east and west, and where the campus abuts the N 120th Street right-of-way to the north), and is considered the Preferred Alternative. Refer to Chapters 2 and 3 of this Final EIS for details on Alternative 3.

UWMC-Northwest
Major Institution Master Plan Update

Draft EIS Comment Form

UWMC invites your comments on the Draft Major Institution Master Plan Update and Draft Environmental Impact Statement. Written comments may be mailed to Julie Blakeslee, Univ. of Washington, Box 352205, Seattle, WA 98195-2205 or emailed to NorthwestMIMP@uw.edu.

Contact Information

Please Print

Name: THOMAS GRIME Affiliation, if any: _____

Address: 11827 STENDAL DR. N.

City: SEATTLE State: WA Zip: 98133

E-mail address: tgrime123@gmail.com

Completing this form will automatically add you to the mailing list. If you prefer not to be on the mailing list, please check the box to the right. I do not wish to be on the project mailing list.

Please print your comment below:

I STRONGLY OBJECT TO THE PROPOSED 120TH ENTRY/EXIT.
 THERE IS AN ADJACENT NEIGHBORHOOD DIRECTLY NORTH -
 ACROSS THE STREET ALONG 120TH.
 THE POTENTIAL HEAVY TRAFFIC OF VEHICLES, BUSES,
 AND AMBULANCES WOULD BE TOTALLY UNACCEPTABLE FOR THE
 RESIDENTS (2100 PEOPLE) OF STENDAL PLACES.
 STENDAL'S MAIN ENTRANCE WITH OUR NEIGHBORHOOD
 WOULD LIMIT OUR ENTRY + EXIT.
 INCREASING THE 115TH ENTRANCE WOULD BE MUCH
 BETTER ACCOMMODATED THE INCREASED TRAFFIC.

1

Comments must be received or postmarked by October 5, 2023

RESPONSE TO LETTER 23

Grine, Thomas

1. The *2024 MIMP Update* and Final EIS Alternative 3 (Preferred Alternative) identifies N 115th Street as the preferred location for a third driveway. Refer to Chapters 2 and 3 of this Final EIS for details on Alternative 3.

From: [Kat Harding](#)
To: NorthwestMIMP@uw.edu
Subject: feedback on UWMC Northwest Hospital Major Institution Master Plan
Date: Thursday, October 5, 2023 3:20:10 PM

I live in the Haller Lake neighborhood near Northwest Hospital and would like to submit feedback on the proposed MIMP.

Entrance on N 120th St: I strongly discourage this option. The surrounding neighborhood has no sidewalks and there are plenty of people taking walks with their kids and dogs on the streets. Adding traffic to this area for hospital access would be a terrible idea.

1

Setbacks and height limits: I recommend running a daylight/shadows study for the proposed setbacks and heights to confirm that taller buildings would not throw significant shade on the neighbors throughout most of the year.

2

Other: I don't know if this would be covered by the MIMP, but it would be a great positive impact to the neighborhood if the hospital could connect its various sidewalks, paths, and crosswalks from the south edge of campus to the north edge pedestrian gates. I used to walk my babies around the neighborhood and on campus, and the only way to get from the 120th St gates to the Starbucks (or to cut through to 117th St) required cutting through either a hospital building or across a grassy lawn that goes right by the daycare playground. A fully connected outdoor paved loop would be much better.

3

Thanks.

Kat Harding

RESPONSE TO LETTER 24

Harding, Kat

1. Comment noted. At the time of writing, construction of curb, gutter and sidewalks along N 120th Street adjacent to the medical center property was underway. The *2024 MIMP Update* and Final EIS Alternative 3 (Preferred Alternative) identifies N 115th Street as the preferred location for a third driveway.
2. Shadow simulations were prepared as part of the analysis for Section 3.4 (Aesthetics/Light & Glare/Shadows). Simulations were completed to provide a comparison of existing shadow conditions and shadow conditions under the *2024 MIMP Update* (Alternatives 1 and 2) for three times of the year (vernal Equinox, Summer Solstice, and Winter Solstice). The shadow simulations illustrate the anticipated potential for shadows to affect adjoining properties, including residential neighborhoods. The Draft EIS indicates that potential future development under the *2024 MIMP Update* would result in an increase in shadows on campus and adjacent areas associated with new buildings and campus landscaping. However, in general these shadows would be cast over areas that already receive shadows from existing buildings and mature trees, and the level of shading would not substantially increase compared to existing conditions at off-campus area.
3. Support for pedestrian connectivity through campus noted. The UWMC is committed to improving campus circulation for all modes, including pedestrians, as projects are developed.

From: [Cindy Howard](#)
To: NorthwestMIMP@uw.edu
Subject: Plan for entry way off 120th
Date: Tuesday, October 3, 2023 4:51:13 PM

Hello!

I'm a neighbor who was born in 1955 and played on the grounds before the hospital was built in 1960. My dad worked in the main office of the hospital and I had my 3 children there. My mother was a Candy Striper (volunteer) in the 60's and lived on 122nd and Ashworth from 1950 -2023. Our family has had a strong relationship with UW Northwest and been a big supporter for many many years.

1

Please, do not consider an entryway off of 120th. The original entrance was off 120th until the hospital suffered growing pains! This is a quiet street and a pathway for children walking to Ingraham and John Baldwin schools. It makes more sense to add a third opening on 115th, to keep all entrance on the same street that has very little residential housing.

2

We are a tight community and value the concerns of our fellow neighbors.

Thank you for your cooperation,

Cindy Harkness Howard
12230 Ashworth Ave N
206-484-6521

RESPONSE TO LETTER 25

Howard, Cindy

1. The comment regarding the commenter's experience and relationship with UWMC Northwest is noted.
2. The *2024 MIMP Update* and Final EIS Alternative 3 (Preferred Alternative) identifies N 115th Street as the preferred location for a third driveway. Refer to Chapters 2 and 3 of this Final EIS for detail on Alternative 3.

From: [Behnaaz Kouhi](#)
To: NorthwestMIMP@uw.edu
Subject: NWH Access Point on N. 120th Street
Date: Wednesday, October 4, 2023 11:43:22 PM

Hello,

My family and I reside in the neighborhood on N. 120th Street. After over two years of enduring constant construction and pollution, we ask you to reconsider adding that third access point on N 120th Street. In relation to this ongoing construction, we've had increased traffic with parking in areas where workers should not be parking and littering. These 2+ years have been incredibly difficult on everyone in the neighborhood and we have been looking forward to the day our area is peaceful again. If this third access point were to be created, the neighborhood would be put under extreme stress with the extra traffic and everyone would be unhappy. We are all concerned and asking for a reconsideration for the health of this neighborhood. Thank you.

RESPONSE TO LETTER 26

Kouhi, Behnaaz

1. The comments regarding the disruptive nature of construction and opposition to a third access from N 120th Street are noted.

Please refer to Section 3.8 (Construction Impacts) of the Draft EIS for discussion on impacts and mitigation associated with construction.

The *2024 MIMP Update* and Final EIS Alternative 3 (Preferred Alternative) identifies N 115th Street as the preferred location for a third driveway. Refer to Chapters 2 and 3 of this Final EIS for discussion on Alternative 3.

From: [tom lang](#)
To: NorthwestMIMP@uw.edu
Subject: Bike connections to the campus
Date: Wednesday, October 4, 2023 1:30:01 PM

Hello UWMC-Northwest Master Planning Committee,

I am a resident in the ALUV neighborhood who is writing to request and validate that bike routes to and through the new campus are an important element of the improvements in the master plan that has been developed.

I believe any new developments and infrastructure plans should include a plan for mobility so residents can walk and bike more easily in North Seattle. I toured your campus on my bike with a few members of the Aurora Reimagined Coalition and we noticed that there is a natural place to put a bike path on the west side of the campus - especially if there is access from Ashworth Ave N into the northwest parking lot for bikes and pedestrians.

I hope you will continue to be a good neighbor by creating a safe and accessible path for bikers, walkers and other non-motorized transportation through campus.

Thank you,

Tom Lang

RESPONSE TO LETTER 27

Lang, Tom

1. Comments regarding bike and pedestrian access through campus noted. The UWMC is committed to improving campus circulation for all modes as projects are developed incrementally. The exact location of development and a loop road and their design are not yet determined. Please refer to Response to Letter 5 (Stendall Place Homeowner's Association) comments 13, and 14, and Chapters 2 and 3 of this Final EIS for discussion on the loop road.

From: Patricia Lewis <pajale@mac.com>
Sent: Tuesday, October 3, 2023 6:50 AM
To: NorthwestMIMP@uw.edu
Subject: Northwest MIMP 120th entrance

Hello-

I am writing as a neighbor with concerns about the proposed entrance on 120th street.

120th street is a quiet residential street. Current traffic is limited as only access to homes. Adding a public entrance to the medical center would increase traffic and adversely affect the homes in our neighborhood. 115th allows direct access from Aurora. Using 120th would require snacking through a residential area.

I hope the planners continue to be respectful of the haller lake neighborhood and do NOT add a public entrance on 120th street.

Thank you,
Patricia Lewis
Burke Ave N

1

RESPONSE TO LETTER 28

Lewis, Patricia

1. The *2024 MIMP Update* and Final EIS Alternative 3 (Preferred Alternative) identifies N 115th Street as the preferred location for a third driveway. Please refer to Chapters 2 and 3 of this Final EIS for discussion on Alternative 3.

UWMC-Northwest
Major Institution Master Plan Update

Draft EIS Comment Form

UWMC invites your comments on the Draft Major Institution Master Plan Update and Draft Environmental Impact Statement. Written comments may be mailed to Julie Blakeslee, Univ. of Washington, Box 352205, Seattle, WA 98195-2205 or emailed to NorthwestMIMP@uw.edu.

Contact Information

Please Print

Name: NEIL MacDOUGALL Affiliation, if any: STEDDALL PI (Community)
Address: 11824 STEDDALL PI N
City: SEATTLE State: WA Zip: 98133
E-mail address: NEIL4568@MSN.COM

Completing this form will automatically add you to the mailing list. If you prefer not to be on the mailing list, please check the box to the right. I do not wish to be on the project mailing list.

Please print your comment below:

IMPACT OF TALL BUILDINGS WITH PROPOSED SETBACKS ARE UNACCEPTABLE. HAS ANYONE COME INTO STEDDALL PI TO LOOK AT THE IMPACT? E BUILDING IS ALREADY AT ABOUT 235 FT SETBACK. A SHADOW STUDY NEEDS TO BE COMPLETED FROM THE WEST PROPERTY. I WOULD LIKE THE COMMITTEE TO COME TO MY PROPERTY FOR THE STUDY TO SEE HOW THE IMPACT WILL BE.

1

2

Comments must be received or postmarked by October 5, 2023

RESPONSE TO LETTER 29

MacDougall, Neil

1. The comment regarding opposition to potential building heights and setbacks under the Draft *2024 MIMP Update* is noted. Section 3.4 (Aesthetics/Light & Glare/Shadows) includes a comprehensive analysis of potential view conditions under the Draft *2024 MIMP Update*. The analysis includes visual massing simulations prepared for Alternatives 1 and 2 based on photographs of the campus from selected viewpoints and simulations of potential development from these viewpoints. The identification of viewpoints for the visual analysis was based on the availability of views to potential development on campus from publicly accessible areas in the vicinity. Seven viewpoints were selected as being most representative of area views and/or were determined to have the greatest potential for development under the Draft *2024 MIMP Update* to change the character of the view.
2. Shadow simulations were prepared as part of the analysis for Section 3.4 (Aesthetics/Light & Glare/Shadows). Simulations were completed to provide a comparison of existing shadow conditions and shadow conditions under the Draft *2024 MIMP Update* (Alternatives 1 and 2) for three times of the year (vernal Equinox, Summer Solstice, and Winter Solstice). The shadow simulations illustrate the anticipated potential for shadows to affect adjoining properties, including residential neighborhoods. The Draft EIS indicates that potential future development under the Draft *2024 MIMP Update* would result in an increase in shadows on campus and adjacent areas associated with new buildings and campus landscaping. However, in general these shadows would be cast over areas that already receive shadows from mature trees and existing buildings, and the level of shading would not substantially increase compared to existing conditions at off-campus area. Alternative 3 (Preferred Alternative) would cast similar or lower level of shadows than those anticipated under Alternative 1 or 2.

From: Kelly Mangiaracina <kelly.mangiaracina@gmail.com>
Sent: Monday, October 2, 2023 11:33 AM
To: NorthwestMIMP@uw.edu
Subject: comment on Northwest Hospital improvements

Good morning,

I am a neighbor of Northwest Hospital (Burke and 120th) and overall am excited about the upgrades being considered for the campus. My one major concern is the possibility about creating an entrance on 120th street. Right now the entrance is on 115th.

The current entrance is on a through street with one side being the hospital and the other being the cemetery. 120th is a residential street and is not a through street. Opening an entrance on 120th would drastically increase trafficking in a residential area. Please consider not having an entrance on 120th. Thank you.

Kelly Mangiaracina
206.229.9528
12015 Burke Ave N, Seattle, WA 98133

1

RESPONSE TO LETTER 30
Mangiaracina, Kelly

1. Comments noted. The *2024 MIMP Update* and Final EIS Alternative 3 (Preferred Alternative) identifies N 115th Street as the preferred location for a third driveway. Refer to Chapter 2 and 3 of this Final EIS for detail.

From: celia.matson
To: NorthwestMIMP@uw.edu
Subject: feedback on NWMP
Date: Tuesday, October 3, 2023 10:18:31 AM

Hi, Julie

Thanks for the opportunity to comment. on the proposed plan. I live in the neighborhood but can't see your campus. I am very glad it's there.

Here's the thing---the bulk and the massively high structures are going to completely dominate that part of the Haller Lake area. Please increase the setbacks you have in the plan, and try to break up the height of the buildings so some light gets through, especially for the folks right in the shadow (north of your campus). To mitigate the inevitable loss of property value for those homes on 120th and 121st, please don't also put an entrance there.

1

2

Thank you.
Celia

RESPONSE TO LETTER 31

Matson, Cella

1. Based on analysis conducted for the Draft EIS, and on comments received from the public and agencies on the Draft *2024 MIMP Update* and Draft EIS, an additional EIS Alternative (Alternative 3) has been identified for this Final EIS. Alternative 3 provides updated building height overlays (a reduction in height in the north portion of the campus) and perimeter building setback areas (an increase to 40-foot building setback where the campus abuts residential properties to the east and west, and where the campus abuts the N 120th Street right-of-way to the north), and is considered the Preferred Alternative. Refer to Chapters 2 and 3 of this Final EIS for detail on Alternative 3.
2. The *2024 MIMP Update* and Final EIS Alternative 3 (Preferred Alternative) identifies N 115th Street as the preferred location of a third driveway access. Refer to Chapters 2 and 3 of this Final EIS for discussion on Alternative 3.

UWMC-Northwest
Major Institution Master Plan Update

Draft EIS Comment Form

UWMC invites your comments on the Draft Major Institution Master Plan Update and Draft Environmental Impact Statement. Written comments may be mailed to Julie Blakeslee, Univ. of Washington, Box 352205, Seattle, WA 98195-2205 or emailed to NorthwestMIMP@uw.edu.

Contact Information

Please Print

Name: Carol Mayes Affiliation, if any: neighbor

Address: 1908 N. 122nd St

City: Seattle State: WA Zip: 98133

E-mail address: mtesteng@aol.com

Completing this form will automatically add you to the mailing list. If you prefer not to be on the mailing list, please check the box to the right. I do not wish to be on the project mailing list.

Please print your comment below:

I appreciate this opportunity.
A major consideration is opening an entrance on 120th. This is a neighborhood with peoples homes, many of us walk and jog here. Why not just open a new or bigger access on 115th, across from the cemetery, (No one would complain)

Please consider carefully. A new access on 120th seems irresponsible and unconcerned with peoples lives and comfort.
Thank you.

1

Comments must be received or postmarked by October 5, 2023

RESPONSE TO LETTER 32

Mayes, Carol

1. Comments noted. The *2024 MIMP Update* and Final EIS Alternative 3 (Preferred Alternative) identifies N 115th Street as the preferred location for a third driveway. Refer to Chapters 2 and 3 of this Final EIS for discussion on Alternative 3.

Kenneth and Pamela McElmeel

(206) 355-0154

11816 Stendall Drive N.

Seattle, WA 98133

September 23, 2023

Re: Major Improvement Master Plan-public comment

As residents and owners of unit 67 in the Stendall Place community, our home along with those of our fellow Stendall owners and our Haller Lake neighbors are located adjacent to the north and west fence of the Northwest UWMC. Our Stendall Place community came into being in the early eighties and the units are highly sought after properties in the north Seattle real estate market. For the past 40 years the Stendall Place HOA and management companies have worked industriously to maintain Stendall Place's beautiful landscaping and attractive properties as well as the peaceful, calm ambience that fits into the entire Haller Lake neighborhood of single-family homes. The Stendall Place community is unique in both its local configuration and its existence in the north Seattle real estate market as there are no other comparable properties in the area. Currently, the surrounding neighborhood, including UWMC, greatly contributes to this with low traffic on streets that access schools, shopping, medical facilities, parks, etc. and a quiet attractive urban environment. The most active, noisiest areas (ER, front entrance, BH building and medical offices) of UWMC are located several blocks away as are the significantly imposing buildings on the UWMC campus.

1

Understanding that change is inevitable, and expansion is needed, whatever changes being considered by UWMC Master Improvement Plan absolutely must strive to maintain this "good neighbor" standing. The current plan does not demonstrate any sensitivity to the preservation of the atmosphere and values of this single-family residential area nor to the peaceful ambience of the residents.

This Master Improvement Plan heavily impacts our community in several ways:

1.0 Increased traffic on 120th street via an added UWMC entrance/exit. The corridor of 120th from Meridian to Ashworth was not constructed to accommodate increased traffic, especially larger vehicles such as buses and

2

semi-trailers. This area has single family homes with their driveways entering as well as being the main entry for the residents of 67 units in Stendall Place. The proposed entry will increase traffic and noise and create unsafe traffic hazards as residents leave and enter our driveways. Stendall Place frequently has unwanted traffic on our roadway by drivers confused with the ending of 120th at the Stendall Place entry. They must turn onto Ashworth to continue with a public street. Currently, it is a problematic corner. Increased traffic would make it very dangerous. **Locate all UWMC entrances on 115th.**

2 Cont.

2.0 Setback changes. The proposed change of the set-back distance along the north and west half of the property from 120 ft. to far less will significantly impact the privacy and value of the single-family homes and Stendall Place units adjacent to those areas. Any construction in these areas would require mature canopy trees and a few snags be removed decreasing the shade and privacy as well as blighting the current view. *This would also affect the resting areas of the hawks and eagles that hunt in the Washelli/Haller Lake/Stone Avenue right-of-way area and nesting habitat of smaller birds and animals.* **Maintain a 50 ft. set-back distance to protect the homes on the north and ½ of the west and east property lines where residents currently exist.**

3

3.0 Height changes. The proposed changes of building heights are doubling or tripling the current standards. It cannot be emphasized enough that any structure with these kinds of heights placed inappropriately on the Northwest UWMC campus will have major detrimental effects on the surrounding environment. The lighting and noise will increase. The view and privacy factors will dramatically decrease not to mention the property values. No one wishes to have an enormous building, or any tall building, looming over their backyard. Proper placement and reducing the proposed height changes could mitigate some of these significant negative effects. **Relegate all multi-story buildings to the areas on the south and east parts of the campus where no private single-family homes will be over-shadowed.**

4

Your attention to these comments is appreciated. Thank you for taking input and, hopefully, incorporating these ideas into the final plan.

RESPONSE TO LETTER 33
McElmeel, Kenneth and Pamela

1. The comments related to the UWMC-Northwest are noted.
2. Comments noted. The *2024 MIMP Update* and Final EIS Alternative 3 (Preferred Alternative) identifies N 115th Street as the preferred location for a third driveway. Refer to Chapters 2 and 3 of this Final EIS for detail on Alternative 3.
3. Based on analysis conducted for the Draft EIS, and on comments received from the public and agencies on the Draft *2024 MIMP Update* and Draft EIS, an additional EIS Alternative (Alternative 3) has been identified for this Final EIS. Alternative 3 provides updated building height overlays (a reduction in height in the north portion of the campus) and perimeter building setback areas (an increase to 40-foot building setback where the campus abuts residential properties to the east and west, and where the campus abuts the N 120th Street right-of-way to the north), and is considered the Preferred Alternative. Refer to Chapters 2 and 3 of this Final EIS for detail on Alternative 3.

Please also refer to Response to Letter 5 (Stendall Place Homeowner's Association) for specific discussion related to Stendall Place.

4. Comments noted. Please see response to comment 3 of this letter.

From: STAN MCNAUGHTON <kathstan2@aol.com>
Sent: Thursday, September 21, 2023 7:53 AM
To: NorthwestMIMP@uw.edu
Subject: Public Comment McNaughtons

This is a public comment from the McNaughton's at 11923 Stendall Dr N. Seattle WA 98133 in regards to the new plan of UW Medical Center Northwest Campus.

We strongly recommend the following:

1. ENTRANCE

No access road on 120th Street.

1

2. LAND USE PLANS AND POLICIES

- * A 40-50ft set back for the North Side
- * A 40-50ft set back for the North 1/2 of the West Side
- * A 40-50 set back for the East side

2

3. HEIGHT LIMITS

A 175ft height limit to be restricted to the southern 2/3 of the property area.

3

Thank you,
Stan and Kathy McNaughton
11923 Stendall Drive N
Seattle, WA 98133

Sent from my iPhone

RESPONSE TO LETTER 34
McNaughton, Stan and Kathy

1. The *2024 MIMP Update* and Final EIS Alternative 3 (Preferred Alternative) identifies N 115th Street as the preferred location for a third driveway. Please refer to Chapters 2 and 3 of this Final EIS for discussion on Alternative 3.
2. Based on analysis conducted for the Draft EIS, and on comments received from the public and agencies on the Draft *2024 MIMP Update* and Draft EIS, an additional EIS Alternative (Alternative 3) has been identified for this Final EIS. Alternative 3 provides updated building height overlays (a reduction in height in the north portion of the campus) and perimeter building setback areas (an increase to 40-foot building setback where the campus abuts residential properties to the east and west, and where the campus abuts the N 120th Street right-of-way to the north), and is considered the Preferred Alternative. Refer to Chapters 2 and 3 of this Final EIS for detail on Alternative 3.
3. Comment noted. Please see response to comment 2 of this letter.

UWMC-Northwest
Major Institution Master Plan Update

Draft EIS Comment Form

UWMC invites your comments on the Draft Major Institution Master Plan Update and Draft Environmental Impact Statement. Written comments may be mailed to Julie Blakeslee, Univ. of Washington, Box 352205, Seattle, WA 98195-2205 or emailed to NorthwestMIMP@uw.edu.

Contact Information

Please Print

Name: DIANE & DENNIS ^{MICHALENKO} Affiliation, if any: STENDALL PL. N.
Address: 11818 STENDALL PL. N.
City: SEATTLE State: WA Zip: 98133
E-mail address: dmichalenko@comcast.net

Completing this form will automatically add you to the mailing list. If you prefer not to be on the mailing list, please check the box to the right. I do not wish to be on the project mailing list.

Please print your comment below:

We have lived here for 10 years and loved each day. It saddens that Northwest Hospital has chosen to interfere with our tranquil existence. We can't imagine having a 175 wall to look at next to us - blocking out sunlight and "just light". The fact that you are proposing an entrance off 120th is alarming to the entire neighborhood since 120th is not a through street. It will invade our privacy and well being. We agree with the entire packet that our Development Review Committee that was prepared by our HOA.

Comments must be received or postmarked by October 5, 2023

Please do not impact our property.
Diane Michalenko

RESPONSE TO LETTER 35
Michalenko, Diane and Dennis

1. Section 3.4 (Aesthetics/Light & Glare/Shadows) includes a comprehensive analysis of potential view conditions under the proposed *2024 MIMP Update*. The analysis includes visual massing simulations prepared for Alternatives 1 and 2 based on photographs of the campus from selected viewpoints and simulations of potential development from these viewpoints. The shadow simulations were also prepared for the Draft EIS to provide a comparison of existing shadow conditions and shadow conditions under the *2024 MIMP Update* (Alternatives 1 and 2) for three times of the year (vernal Equinox, Summer Solstice, and Winter Solstice). The shadow simulations illustrate the anticipated potential for shadows to affect adjoining residential neighborhoods. Shadow impacts under Final EIS Alternative 3 would be equal to or less than those identified in the Draft EIS for Alternatives 1 and 2.

2. The *2024 MIMP Update* and Final EIS Alternative 3 (Preferred Alternative) identifies N 115th Street as the preferred location for a third driveway. Please refer to Chapters 2 and 3 of this Final EIS for detail on Alternative 3.

From: Dan Mohr <dmohr06@gmail.com>
Sent: Thursday, September 21, 2023 2:22 PM
To: Debora.juarez@seattle.gov; northwestMIMP@uw.edu
Subject: Letter of objection to proposed UW Medicine entrance on 120th St, Seattle

Attn: Deborah Juarez at Seattle City Council, Julie Blakeslee at Seattle Department of Construction and Planning

Dear Ms. Juarez and Ms. Blakeslee,

I am writing on behalf of my spouse Janie Mohr and myself, to object to the proposed UW Medicine entrance on 120th St. in Seattle, WA, 98133.

Our neighborhood is compact, residential, and filled with families and children. A new UW Medicine entrance on 120th St. would greatly increase the vehicle traffic through our area, and become substantially noisier and less safe for neighborhood residents and pedestrians. Thank you very much for your time and consideration.

1

Respectfully yours,

Dan and Janie Mohr
1522 N. 121st St, Seattle, WA, 98133
Cell: 206-480-7500
Email: dmohr06@gmail.com

RESPONSE TO LETTER 36

Mohr, Dan and Janie

1. The *2024 MIMP Update* and Final EIS Alternative 3 (Preferred Alternative) identifies N 115th Street as the preferred location for a third driveway. Please refer to Chapter 2 and 3 of this Final EIS for detail on Alternative 3.

To: Northwest MIMP

Date: 10-4-23

Subj: UWMC NW Hospital Comment Period # 4

Northwest Hospital has been a great Haller Lake area neighbor.

I have lived on the south end of the Lake since 1988.

The new 20 year expansion plan for the Hospital does raise the following impact concerns:

- (A). Current traffic flow on Meridian Avenue North to the intersection at N.122nd Street is already congested. Your plans to open Hospital access on the North side and use 120th Street North will make it worse... Would need a traffic light at N. 122nd and Meridian causing backups, more noise and resulting safety issues. The existing South end access to the Hospital lessens this congestion impact greatly. The intersection referenced is already a nightmare and dangerous. 1
- (B). Set back for any new construction should be a minimum of 40-50 feet on North side and the the North 1/2 of both the Westside and Eastside Hospital properties. Otherwise you are right next to existing residences. Encroachment on our neighbors is not ideal. 2
- (C). Construction of a 175 foot tall Building on the Northside of the Hospital affects all residential and closed loop neighborhoods in an adverse way. Locating this new building on Southern 2/3 of the property would have no effect on on the neighborhood as this borders the cemeteries anyway. No one wants a 175 foot Building right on top of them. 3

Thank you for your consideration of these valid concerns...

R.D. Moore
1736 N. 122nd Street
Seattle, WA 98133

Phone: (206) 367-2344

Regards,

Randy Moore

Relwy@aol.com



RESPONSE TO LETTER 37

Moore, Randy

1. The *2024 MIMP Update* and Final EIS Alternative 3 (Preferred Alternative) identifies N 115th Street as the preferred location for a third driveway. Please refer to Chapters 2 and 3 of this Final EIS for discussion on Alternative 3.
2. Based on analysis conducted for the Draft EIS, and on comments received from the public and agencies on the Draft *2024 MIMP Update* and Draft EIS, an additional EIS Alternative (Alternative 3) has been identified for this Final EIS. Alternative 3 provides updated building height overlays (a reduction in height in the north portion of the campus) and perimeter building setback areas (an increase to 40-foot building setback where the campus abuts residential properties to the east and west, and where the campus abuts the N 120th Street right-of-way to the north), and is considered the Preferred Alternative. Refer to Chapters 2 and 3 of this Final EIS for detail on Alternative 3.
3. Comment noted. Please see response to comment 2 of this letter.

From: [Lilla O'Grady](mailto:Lilla_O'Grady@uw.edu)
To: NorthwestMIMP@uw.edu
Subject: Feedback and comments on DEIS documents
Date: Monday, September 25, 2023 1:14:55 PM

I am a resident of Stendall Place which is the community bordering the Northwest perimeter of UWMC- Northwest. I have reviewed the proposals for development in the DEIS and have concerns that I hope will be addressed in changes made in the final Environmental Impact Statement. They are as follows:

1. I oppose the proposed additional access road to N. 120 th Street because this street is too narrow and burdened by traffic to safely accommodate additional access. | 1

2. Regarding the proposed setbacks, please consider 40-50 feet setbacks along the upper one-half of the Northwest property line and east side of the property. These homes have small backyards abutting the property border and would be greatly impacted both visually and in terms of light and shadow effects from taller buildings. | 2

3. I ask that the requested height limitations of 65 and 175 feet be confined to the lower one half of the western property edge adjacent to the cemetery and centrally and along the N. 115 th Street corridor. | 3

Thank you for these considerations as they are very important to us, your ongoing property neighbors who have been good supporters of your endeavors and hope to remain so.

Sincerely,
Dr. Lilla O'Grady
11808 Stendall Dr. N.

Sent from my iPad

RESPONSE TO LETTER 38

O'Grady, Lilla

1. The 2024 *MIMP Update* and Final EIS Alternative 3 (Preferred Alternative) identifies N 115th Street as the preferred location for a third driveway. Please refer to Chapters 2 and 3 of this Final EIS for discussion on Alternative 3.
2. Based on analysis conducted for the Draft EIS, and on comments received from the public and agencies on the Draft 2024 *MIMP Update* and Draft EIS, an additional EIS Alternative (Alternative 3) has been identified for this Final EIS. Alternative 3 provides updated building height overlays (a reduction in height in the north portion of the campus) and perimeter building setback areas (an increase to 40-foot building setback where the campus abuts residential properties to the east and west, and where the campus abuts the N 120th Street right-of-way to the north), and is considered the Preferred Alternative. Refer to Chapters 2 and 3 of this Final EIS for detail on Alternative 3.
3. Comment noted. Please see response to comment 2 of this letter.



Lilla O'Grady

123-456-7890 no_reply@example.com 1234 Main Street Anytown, State ZIP

September 25, 2023

Julie Blakeslee
University of Washington
Box 352205
Seattle, WA 98195-2205

Re: DEIS Documents, UW Medical Center-Northwest

Dear Julie Blakeslee,

I reside at Stendall Place which is the community bordering the Northwest border of UW Medical Center- Northwest. I have the following concerns after reviewing the proposed alternatives in the DEIS which I hope will be addressed before the Final EIS .

1. I am opposed to an additional access road on N.120th Street. 120th Street is too narrow and burdened by traffic to safely accommodate additional access. | 1
2. I favor 40-50 foot setbacks especially adjacent to the residential properties along the northwest property line and along the eastern side of the Medical Center property. | 2
3. I ask that the requested height changes be confined to the lower one half of the western property edge , the center of the property, and along the N. 115th Street corridor. The proposed height increase to 175 feet would greatly impact adjacent properties visually as well as adversely affect light and shadow quality for these properties. | 3

Sincerely yours,

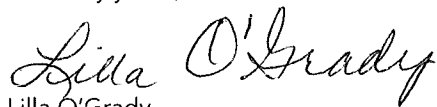
Lilla O'Grady

11808 Stendall Dr. N.

Seattle, WA 98133

RESPONSE TO LETTER 39

O'Grady, Lilla

1. Please refer to Response to Letter 38 (O'Grady, Lilla) comment 1.
2. Please refer to Response to Letter 38 (O'Grady, Lilla) comment 2.
3. Please refer to Response to Letter 38 (O'Grady, Lilla) comment 3.

From: [poyer.belanger](#)
To: northwestmimp@uw.edu
Subject: Comment on UWMC Northwest Hospital masterplan.
Date: Sunday, September 24, 2023 5:22:33 AM

I am opposed to the hospital opening an entrance on N 120th St. This is a closed loop neighborhood. The city has deemed this a safe zone for students to walk through to get to both the high school and elementary school. The streets in this neighborhood are not set up for more traffic. The corner at 120th and Ashworth is a tight turn with no room for more than one car at a time.

Thank you.
Doug Poyer

Get [Outlook for Android](#)

RESPONSE TO LETTER 40

Poyer, Doug

1. The comments regarding N 120th Street are noted. The *2024 MIMP Update* and Final EIS Alternative 3 (Preferred Alternative) identifies N 115th Street as the preferred location for a third driveway. Please refer to Chapters 2 and 3 of this Final EIS for discussion on Alternative 3.

From: [Tanya Roesijadi](#)
To: NorthwestMIMP@uw.edu
Subject: UWMC – Northwest Major Institution Master Plan pedestrian & bicycle safety
Date: Tuesday, October 3, 2023 9:46:46 PM

Hi,

I live near UW Northwest in Licton Springs & ride my bike through campus often to stay on calmer streets while traveling east of Aurora. I also bike or walk to my medical appointments at UW Northwest. Can the new plan for the hospital campus include safe walking & biking onfrast for the community who goes to campus and travels through this area?

1

N 110th street that borders the Licton Aurora Urban Village has high speed traffic that is faster than posted speed limits. It can feel dangerous crossing that street to get to UW Northwest. Can the master plan address safe crossing of N 110th street bordering UW Northwest campus?

2

Thank you,
Tanya Roesijadi

RESPONSE TO LETTER 41

Roesijadi, Tanya

1. Comments regarding bike and pedestrian access through campus noted. The UWMC is committed to improving campus circulation for all modes of transportation, including safe walking and biking, as projects are developed. UWMC will continue to be a supporting community member for safe streets.
2. Only the UWMC-Northwest campus, bordered by N 115th Street and N 120th Street, is included in this master plan. The Final EIS identifies a potential traffic signal added to N 115th Street when development in the MIMP timeframe occurs, which would include pedestrian crosswalks.

UWMC-Northwest
Major Institution Master Plan Update

Draft EIS Comment Form

UWMC invites your comments on the Draft Major Institution Master Plan Update and Draft Environmental Impact Statement. Written comments may be mailed to Julie Blakeslee, Univ. of Washington, Box 352205, Seattle, WA 98195-2205 or emailed to NorthwestMIMP@uw.edu.

Contact Information

Please Print

Name: PAULLA ROSS Affiliation, if any: _____

Address: 11712 STENDALL DR. N

City: SEATTLE, State: WA Zip: 98133

E-mail address: PROSS569@GMAIL.COM

Completing this form will automatically add you to the mailing list. If you prefer not to be on the mailing list, please check the box to the right. I do not wish to be on the project mailing list.

Please print your comment below:

I LIVE NEXT DOOR AT STENDALL PLACE - 67 TOWNHOUSES
IN A BEAUTIFUL P.U.D. I SINCERELY WISH YOUR
DESIGN COMMITTEE WOULD COME VISIT OUR
CAMPUS TO UNDERSTAND WHY WE ARE SO CONCERNE
ABOUT THIS UMMC PROJECT. I WOULD BE HAPPY
TO SHOW YOU AROUND AS WOULD CAROL WHITFIELD
& JOAN HANSON. OUR QUALITY OF LIFE HAS ALREADY
BEEN IMPACTED BY HOMELESS CAMPS ON 120TH &
STONE AVE.

SET BACKS & HEIGHT LEVELS ARE OF EXTREME
IMPORTANCE TO PROTECT OUR PRIVACY & ENJOYMENT
OF OUR HOMES. MANY OF US SELECTED OUR
HOMES BECAUSE OF THE BEAUTY, PRIVACY & SAFETY.
THEY COULD ALL BE SERIOUSLY DAMAGED BY
THIS LARGE COMMUNITY DEVELOPMENT.

I SINCERELY HOPE THAT YOU & THE CITY COUNCIL

Comments must be received or postmarked by October 5, 2023

WILL CONSIDER OUR CONCERNS - FULLY NOTED IN
OUR COMMITTEE'S RECOMMENDATIONS DATE AUGUST 7,
2023. NOT JUST CHECK THE BOX FOR COMMUNITY

1

2

3

RESPONSE TO LETTER 42

Ross, Paula

1. Comments noted. The comment regarding opposition to potential building heights and setbacks under the *2024 MIMP Update* is noted. Section 3.4 (Aesthetics/Light & Glare/Shadows) includes a comprehensive analysis of potential view conditions under the proposed *2024 MIMP Update*. The analysis includes visual massing simulations prepared for Alternatives 1 and 2 based on photographs of the campus from selected viewpoints and simulations of potential development from these viewpoints. The identification of viewpoints for the visual analysis was based on the availability of views to potential development on campus from publicly accessible areas in the vicinity. Seven viewpoints were selected as being most representative of area views and/or were determined to have the greatest potential for development under the *2024 MIMP Update* to change the character of the view
2. Comments noted. Based on analysis conducted for the Draft EIS, and on comments received from the public and agencies on the Draft *2024 MIMP Update* and Draft EIS, an additional EIS Alternative (Alternative 3) has been identified for this Final EIS. Alternative 3 provides updated building height overlays (a reduction in height in the north portion of the campus) and perimeter building setback areas (an increase to 40-foot building setback where the campus abuts residential properties to the east and west, and where the campus abuts the N 120th Street right-of-way to the north), and is considered the Preferred Alternative. Refer to Chapters 2 and 3 of this Final EIS for detail on Alternative 3.
3. The comment regarding neighborhood concerns is noted and all comments received on the DEIS are included and responded to in this FEIS.

From: [Cliff Rosson](#)
To: NorthwestMIMP@uw.edu
Subject: Feedback on Master Plan
Date: Thursday, October 5, 2023 9:18:16 PM

Hi Team,

I am a resident of 121st st and have some concerns on the two MIMP plans alternative 1 and 2.

First I believe alternative 2 fails at its goal. Attempting to lower building height along the north edge allowing for a smaller setback. However at 65' height, 20' isn't nearly adequate enough and in the winter all that 120th gets between the trees comes from the south, through the hospital property. A 65' structure at 20' setback will further make the added 120th greenspace/walkpath additions challenging and dark.

Alternative 1 is a bit better with a bigger setback but with expectations of building height up to 175', now you have a tower right outside people's doors.

I would consider exploring the Alternative 1 option but preferring taller buildings to the south end, adjacent to 115th and the cemetery.

For 120th access I think limiting access to employees might be feasible assuming it doesn't add considerable traffic to 120th. The road is not meant for considerable traffic and really acts more like a dead end for residents. It is a backend residential street, not a through street. It would be best if traffic continued to enter via 115th side with restricted and limited access on the 120th side.

Please consider the residents of 120th. Currently both MIPS alternatives are not ideal for the community.

I do however look forward to the new pathway/greenspace. Thank you for taking my feedback.

--
- Cliff Rosson

1

2

3

RESPONSE TO LETTER 43

Rosson, Cliff

1. Based on analysis conducted for the Draft EIS, and on comments received from the public and agencies on the Draft *2024 MIMP Update* and Draft EIS, an additional EIS Alternative (Alternative 3) has been identified for this Final EIS. Alternative 3 provides updated building height overlays (a reduction in height in the north portion of the campus) and perimeter building setback areas (an increase to 40-foot building setback where the campus abuts residential properties to the east and west, and where the campus abuts the N 120th Street right-of-way to the north), and is considered the Preferred Alternative. Refer to Chapters 2 and 3 of this Final EIS for detail on Alternative 3.
2. The *2024 MIMP Update* and Final EIS Alternative 3 (Preferred Alternative) identifies N 115th Street as the preferred location for a third driveway. Please refer to Chapters 2 and 3 of this Final EIS for detail on Alternative 3.
3. The comment regarding the new pathway/greenspace is noted.

From: [Steve S](#)
To: northwestmimp@uw.edu
Subject: NW Hospital Master Plan
Date: Thursday, October 5, 2023 5:09:35 PM

Hello DAC,

I would like to comment on the NW Hospital Master Plan. Overall, I think it was a bad idea to begin with. UW should have used the OPMC site on Meridian Ave North for the new tower if that location is owned by UW. This new site will cause major traffic issues and degrade the quality of the neighborhood adjacent to the hospital. I would like to oppose a new access road on N. 122nd St.

1

I feel you should stay with the existing height limits 37, 50 and 105 feet. Setbacks for the north side, the north half of the east and west side should be 50 or more feet. Thank you.

2

Respectfully,
Steven Saunders

RESPONSE TO LETTER 44

Saunders, Steven

1. Comment noted. Additional patient care space is needed on campus to meet health care demands in the area. The *2024 MIMP Update* does not include the OPMC site.
2. Comments noted. The needed program space of 1.6 million square feet cannot be developed within the existing height limits.

Based on analysis conducted for the Draft EIS, and on comments received from the public and agencies on the Draft *2024 MIMP Update* and Draft EIS, an additional EIS Alternative (Alternative 3) has been identified for this Final EIS. Alternative 3 provides updated building height overlays (a reduction in height in the north portion of the campus) and perimeter building setback areas (an increase to 40-foot building setback where the campus abuts residential properties to the east and west, and where the campus abuts the N 120th Street right-of-way to the north), and is considered the Preferred Alternative. Refer to Chapters 2 and 3 of this Final EIS for detail on Alternative 3.

From: [Jeanne Schollmeyer](mailto:Jeanne.Schollmeyer@uw.edu)
To: NorthwestMIMP@uw.edu
Subject: NW Hospital Master Plan
Date: Thursday, October 5, 2023 3:17:55 PM

To whom it may concern,

I am gravely concerned over the two alternatives in the Major Institution Master Plan for Northwest Hospital. Being a long time resident of 28th years on North 121st, I find the two plans lacking consideration for the residents of the neighborhood directly in the shadows of the hospital. Being that we have 15 plus the busy Meridian Ave to the east and Aurora Avenue to the west we deal with heavy traffic and it's noise. We must have around 100 people who walk in our sidewalk-less looped neighborhood everyday, it is one of the few places people have to walk that is away from the heavy traffic and it's noise. I plead with you not to open an exit/entrance to the hospital on 120th, which would increase our neighborhood traffic and noise while decreasing our safety. Just last week having to walk on the street on Ashworth Ave North, just north (behind) the hospital my small dog and I were narrowly missed by a speeding car. That these plans want to add to that hazard is to put it mildly, upsetting.

1

2

It is obvious that when the hospital was first built, consideration was given to residents by having given a 120 feet setback at it's northern border. To consider a 20 or 30 feet setback with a looming 17 story building is simply outrageous.

3

I understand that you are considering the public's future healthcare needs but to do so on the backs of the people who reside here is unfortunate. I ask that you consider setting the 175 foot and 65 foot buildings in the southern 2/3rds of the property and provide at least a 40ft setback at the hospital's borders on the east, north and west sides.

4

We are a neighborhood of small children who learn to ride their bikes on these streets, mannies, parents and grandparents stroll babies here, people with and without dogs walk here, even the hospital staff use our dead ends and looped streets for walking during their breaks. Our neighborhood is an island of respite that would be changed for the worse if Alternative Plans 1 or 2 are fully adopted. I plead that more thought be put into the quality of life for the hospital's neighbors.

5

Sincerely,
Jeanne Schollmeyer
1322 North 121st Street
Seattle, WA. 98133

Sent from my iPad

RESPONSE TO LETTER 45

Schollmeyer, Jeanne

1. Comment noted.
2. At the time of writing, construction of curb, gutter, and sidewalk along N 120th Street adjacent to the medical center property was underway. The *2024 MIMP Update* and Final EIS Alternative 3 (Preferred Alternative) identifies N 115th Street as the preferred location for a third driveway. Please refer to Chapters 2 and 3 of this Final EIS for detail on Alternative 3.
3. Comment noted. Additional height is needed to accommodate the total building development and phasing requirements to meet health care demands.

Based on analysis conducted for the Draft EIS, and on comments received from the public and agencies on the Draft *2024 MIMP Update* and Draft EIS, an additional EIS Alternative (Alternative 3) has been identified for this Final EIS. Alternative 3 provides updated building height overlays (a reduction in height in the north portion of the campus) and perimeter building setback areas (an increase to 40-foot building setback where the campus abuts residential properties to the east and west, and where the campus abuts the N 120th Street right-of-way to the north), and is considered the Preferred Alternative. Refer to Chapters 2 and 3 of this Final EIS for detail on Alternative 3. Also note that Alternative 3 includes increased setbacks and step-down heights where possible. For information purposes, the proposed 175-foot height overlay would allow a hospital building of 10-12 stories due to floor-to-floor heights.

4. Please see response to comment 3 of this letter.
5. The comment regarding the existing neighborhood character is noted.

UWMC-Northwest
Major Institution Master Plan Update

Draft EIS Comment Form

UWMC invites your comments on the Draft Major Institution Master Plan Update and Draft Environmental Impact Statement. Written comments may be mailed to Julie Blakeslee, Univ. of Washington, Box 352205, Seattle, WA 98195-2205 or emailed to NorthwestMIMP@uw.edu.

Contact Information

Please Print

Name: Nancy Scholten Affiliation, if any: _____

Address: 11709 Stendall Pl. N.
Seattle, WA 98133-8343

City: _____ State: _____ Zip: _____

E-mail address: mscholten@comcast.net

Completing this form will automatically add you to the mailing list. If you prefer not to be on the mailing list, please check the box to the right. I do not wish to be on the project mailing list.

Please print your comment below:

_____	Recommendations for MIMP: _____

_____	<u>PRIMARY CONCERNS:</u>
_____	<u>Impact on Neighborhood - Stendall Place Residential Property</u>
_____	_____ 1
_____	Recommend NO road along Stendall Place property border.
_____	Traffic concerns. Parking overload on adjacent neighborhood streets.
_____	_____ 2
_____	Height of Building - visual impact of building on neighborhood.
_____	Noise Factor - Construction activities. _____ 3
_____	_____

Nancy Scholten 9/30/23

Resident at Stendall Place

Comments must be received or postmarked by October 5, 2023

RESPONSE TO LETTER 46

Scholten, Nancy

1. The comment regarding opposition to a loop road is noted. Refer to Response to Letter 5 (Stendall Place Homeowner's), comments 4, 13 and 14.
2. The comment regarding building height is noted. Refer to Response to Letter 5a (DAC), comment 60.
3. The comment regarding construction noise is noted. Refer to Response to Letter 5a (DAC), comment 50.

From: Max Severeid <mountainmaximus@yahoo.com>
Sent: Wednesday, October 4, 2023 8:02:08 PM
To: NorthwestMIMP@uw.edu <northwestmimp@uw.edu>
Cc: nelson.pesigan@seattle.gov <nelson.pesigan@seattle.gov>
Subject: UWMC DEIS Comments

Hello UWMC-Northwest Master Planning Committee,

I am a North Seattle resident writing to provide input on the UEMC DEIS campus improvement and master plan development. I also am a member of the Aurora Reimagined Coalition, a non-profit community coalition promoting a more equitable, more pedestrian and bike friendly Aurora corridor for non-motorized travelers (<https://www.got99problems.org/>).

One neat option I hope you might consider including in the MIMP not in there already is constructing a north/south pedestrian, bicycle, and wheelchair accessible pathway, completely separated from vehicle traffic, along the western side of your campus. There is natural, tree-lined corridor already present here, from the Southwest corner at N 115th St and the Bikur Cholim Cemetery fence line, all the way up along the fence line against the cemetery and Stendall Place N community, and up through the locked gate at N 120th St. I've attached some maps below showing the area, with a yellow line indicating the location where such a cool, straight path might be created. In your online plan, this would exist where the image of a person is shown in Figure 3.9 Section A including setback at the west campus edge.

1

This new path would help fulfill a number of MIMP stated goals:

- general access and circulation:
 - provision of connected sidewalks and amenities for navigating not only to and from adjacent campus uses, but across the campus and for community members;
 - expand bike and pedestrian networks to encourage decreased reliance on single occupancy vehicle access to campus and through the campus.
- maintain accessible open space throughout the campus in support of creating a healing environment under the stated landscape intent

I am encouraged your development and infrastructure plan includes non-motorized travel options...but it could do more. Please consider expanding consideration of neighboring community members utilizing this western side of your campus as a great amenity offered not only to patients, but as a community asset and a pass-through connecting residential areas, greenways, and pedestrian routes.

2

I toured your campus on my bike recently with a few members of the Aurora Reimagined Coalition and we noticed that this natural place on the west side of the campus would be great for a path. As we were there, we even saw patients attached to intravenous/IV devices, standing with family members in the middle of the parking lot at the Northwest Pulmonary Function Lab. While trying to get fresh air and talk, sadly they were only able to stand on asphalt and avoid car traffic. Imagine them, instead, walking and visiting along a walking path, separated from cars!

Please reach out if you have any questions or would like more information.

Thank you,

Max Severeid
6415 Woodlawn Avenue N
Seattle, WA 98103
206.919.2194

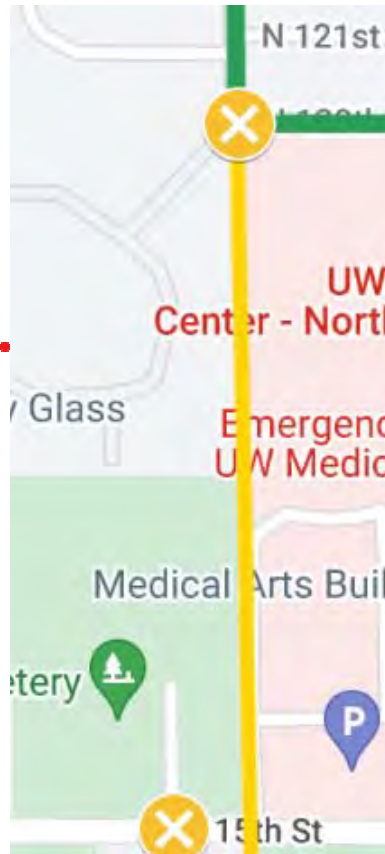

RESPONSE TO LETTER 47

Sevareid, Max

1. Comments regarding bike and pedestrian access through campus noted. The UWMC is committed to improving campus circulation for all modes as projects are developed incrementally. The exact location of development and a loop road and their design are not yet determined. The assessment of pedestrian facilities was updated in the FEIS to include the character and nature of the routes in the vicinity of the campus.
2. Comment noted. As stated in the proposed *2024 MIMP Update* Design Guidance and Development Standards, UWMC is committed to a more pedestrian-oriented campus, with safe options for all modes of travel, as projects are developed incrementally. The incremental demolition and new buildings must take into account safe travel for all. UWMC is not supportive of a pathway at this time as the E-Wing along the western boundary has rooms and clinics at the ground level. In addition, we have heard from neighbors that there is no interest for access on N 120th Street. All competing interests will have to be taken into account for campus access and pathways. It will take some time to bring the medical center infrastructure and campus to the full vision.

From: Jeff Silverman <jeffsilverm@gmail.com>
Sent: Wednesday, October 4, 2023 6:56 PM
To: Northwestmimp@uw.edu
Subject: Comments on the Northwest Hospital Major Institution Master plan

People,

I got a handbill from somebody today with recommenda. ons for neighborhood discussion with the Northwest Hospital MIMP. I'm sure you got them although I do not know from whom.

The handbill recommends against an access road from the north. I disagree. Access to the hospital from N 115 is already a bottleneck.

As the hospital increases in size, the bottleneck will get worse.

Access from the north will also make the hospital more resilient against any disruption from the south.

1

As the number of employees increases and as the price of land in Seattle continues to rise, I would like to make sure that there is provision for more employee parking. I would also like more provision for patient and visitor parking, including more covered walkways, preferably with walls to protect against wind blown rain and snow.

2

Finally, I would like to see you devote some land to caring for homeless people. The homeless are not going to go away, they are merely going someplace else.

3

Sincerely yours,

Jeff

--

Jeff Silverman 🙄💻

to five three for phive niner too tree won ate jeffsilverm 4t gmail.c0m <http://jeffsilverman.ddns.net> See my portfolio of writings and talks

70 micrograms in the arm, or 70 Kilograms in the grave. Choose wisely.

RESPONSE TO LETTER 48

Silverman, Jeff

1. Access Option 1 assuming the addition of a third access via N 115th Street assumes the third access is signalized. Table 3.6-7 of the DEIS shows the third access proposed under either access option (as either a traffic signal via N 115th Street or two-way stop controlled via N 120th Street) is forecast to operate at LOS A with limited queueing. The two remaining access points (the existing driveways along N 115th Street) are forecast to operate with less overall delay and queueing with Option 1 (via N 115th Street) compared to Option 2 (via N 120th Street) as the traffic signal is able to accommodate additional demand and is generally located where more users are naturally inclined to utilize (consistent with distribution patterns).
2. The *2024 MIMP Update* does increase allowed parking supply for all campus users. Parking forecasts accommodate the peak parking demands including employees, patients, visitors, etc.
3. Comment noted. UWMC provides quality healthcare and is currently adding 150 behavioral beds to treat the needs of our community. The campus cannot dedicate its already limited space for homeless encampments or residential uses and meet the regional healthcare demands.

From: [Nina Simonds](#)
To: NorthwestMIMP@uw.edu; jblakesl@us.edu
Subject: Comment on Draft EIS
Date: Wednesday, October 4, 2023 11:35:23 AM

Hello Julie and UWMC-Northwest Master Planning Committee,

I am a Greenwood resident who is writing to request and validate that bike routes to and through the new campus are an important element of the improvements and master plan that has been developed.

I believe any new developments and infrastructure plans should include a plan for mobility so residents can walk and bike more easily in North Seattle. I toured your campus on my bike with a few members of Aurora Reimagined Coalition and we noticed that there is a natural place to put a bike path on the West side of the campus - especially if there is access into the Northwest parking lot for bikes and pedestrians.

1

I hope you will continue to be a good neighbor by creating a safe and accessible path for bikers, walkers and other non-motorized transportation through campus.

2

Please reach out if you have any questions or need more information.

Thank you,

Nina Simonds
9531 Evanston Ave N, Seattle, WA 98103
206.402.6486

RESPONSE TO LETTER 49

Simonds, Nina

1. Comments regarding bike and pedestrian access through campus noted. The UWMC is committed to improving campus circulation for all modes of transportation as projects are developed incrementally, including a loop road. The assessment of pedestrian facilities was updated in the Final EIS to include the character and nature of the routes in the vicinity of the campus. See Chapter 3 (Updates Subsequent to Issuance of the Draft EIS) for detail.
2. Comment noted. See response to comment 1 of this letter.

From: [Catherine Smith](#)
To: northwestmimp@uw.edu
Subject: MIMP comment
Date: Thursday, October 5, 2023 5:03:49 PM

Hi Julie,

I am a local resident of haller lake area and live just north of the proposed project site. I reviewed the draft MIMP and wanted to comment in favor of the alternative #2 for the height and setback plan. Having tall buildings just near the property line would completely change the landscape of our quiet, dead end neighborhood. I support a model where the taller buildings are set back a little farther from 120th st, and the closest buildings are not quite as tall. I fully support the expansion of the hospital to meet the needs of our community, and also would like to preserve the small community feel of my neighborhood as much as possible.

1

2

Thank you for your time.

Sincerely,
Catherine Smith
On Ashworth Ave

RESPONSE TO LETTER 50

Smith, Catherine

1. Support for Alternative 2 is noted. Based on analysis conducted for the Draft EIS, and on comments received from the public and agencies on the Draft *2024 MIMP Update* and Draft EIS, an additional EIS Alternative (Alternative 3) has been identified for this Final EIS. Alternative 3 provides updated building height overlays (a reduction in height in the north portion of the campus) and perimeter building setback areas (an increase to 40-foot building setback where the campus abuts residential properties to the east and west, and where the campus abuts the N 120th Street right-of-way to the north), and is considered the Preferred Alternative. Refer to Chapter 2 and 3 of this Final EIS for detail on Alternative 3. Note that the *2024 MIMP Update* reflects the plan presented in Final EIS Alternative 3.
2. The comment regarding support for expansion of the hospital and preservation of the neighborhood community is noted.

From: [Tricia Williams](#)
To: NorthwestMIMP@uw.edu
Subject: Community Feedback on the UWMC – Northwest Major Institution Master Plan
Date: Friday, September 29, 2023 11:23:52 AM

Good afternoon,

I am a resident and member of the Haller Lake Community and wanted to share some feedback on the development plans for the UWMC campus. Thank you for the opportunity to provide feedback. I understand that the demand for healthcare services continues to grow and as such, some development is good and necessary for the community. And, I can definitely appreciate that it's difficult to expand services within the existing property lines – while preserving the character of the largely residential community UWMC calls home.

1

The biggest concern in my opinion is increased traffic in the neighborhood and not seeing adequate plans to increase capacity on the surface streets of N 115th Street or Meridian Ave N (between 115th and 105th Streets). What are the plans to accommodate more traffic on these streets? There is currently only a 4-way stop at this intersection and no turn lanes on either of these streets or at the UWMC main entrance.

2

The next biggest concern/risk to the integrity of the neighborhood is a proposed new entrance on N 120th Street. Who would use this entrance (over the main one) and more importantly what streets would they come in from other than N 115th or Meridian Ave N? I do not support this idea at all because it would bring even more traffic into the area but on residential streets, including the intersection of First Ave NE and N 117th Street where the new elementary school is located. All of these are residential streets with roundabouts, no sidewalks, etc. making the neighborhood even less safe for residents, school children, and activities like walking your dog.

3

Lastly, I would like to speak to building height limits and setbacks on the North side of the campus bordering N 120th Street. The plans state that an increase to the existing height limits and a reduction in the existing setbacks is required to meet growth projections. Is it possible to see the underlying research done to back up these projections? I don't mean to question the assumptions that have gone into it and have to trust that this plan represents the best thinking of a team of experts. However, I do feel strongly about persevering the character and neighborhood feel of our community in a city where this has become a daily struggle.

4

I am available to speak to someone directly if any additional clarity is needed – and again, the opportunity to share my feedback is greatly appreciated.

Kind regards,

Tricia Williams
triciawilliams@outlook.com
206.853.2652

RESPONSE TO LETTER 51

Williams, Tricia

1. Comments noted.
2. The traffic study prepared for this EIS showed that under all alternatives, mitigation will be necessary at the N 115th St/Meridian Avenue N intersection. The mitigation has been identified as a traffic signal at this location. Additionally, the Final EIS Alternative 3 (Preferred Alternative) has identified a third access via N 115th Street which would be a signalized access and add an eastbound left-turn lane into campus.
3. The *2024 MIMP Update* and Final EIS identifies N 115th Street as the preferred location for a third driveway in Alternative 3.
4. Comments noted. Additional height is needed to accommodate the total building development and phasing requirements to meet health care demands. Please review an added alternative (Alternative 3) that includes increased setbacks and step-down heights where possible.

From: William Woodruff <william@chloewine.com>
Sent: Thursday, September 21, 2023 9:51 AM
To: NorthwestMIMP@uw.edu; Debora Juarez
Subject: Julie: Objection to new ingress for UW Medicine on North 120th North

Julie and Distinguished Seattle City Council Member Deborah Juarez,

Good morning. I live at 1521 North 121st and am a parent of two children whom cycle to school at James Baldwin Elementary School.

1

I object on the grounds of my children's safety as well as the increased traffic flow of our neighborhood.

Please acknowledge receipt of this objection.

--
yours sincerely,

William Woodruff
Chloewine.com
Executive MBA, UW 2008
(206) 284-8159 tel

RESPONSE TO LETTER 52

Woodruff, William

1. The comment regarding objections to the *2024 MIMP Update* due to increased traffic and children's safety is noted. Section 3.6 of the Draft EIS provided a comprehensive analysis of transportation conditions for the 2024 MIMP Update, including an analysis of traffic volumes, traffic operations and traffic safety.

From: [Robert Yates](#)
To: NorthwestMIMP@uw.edu
Cc: [Robert Yates](#)
Subject: Feedback on NW Master Plan
Date: Tuesday, September 26, 2023 5:13:50 PM

Hello and thank you for the opportunity to provide feedback on this plan.

My comments are specific to mitigating the ongoing negative environmental impact of medical centers and delivery of healthcare. Currently 10% of US greenhouse gas emissions result from healthcare delivery, and a unbelievable amount of solid waste results from the US healthcare system.

1

As you plan to expand the volume of clinical care delivered on the NW campus, I would expect that UW medicine will consider all the ways that it can mitigate it's negative impact on the environment and implement all reasonable strategies to demonstrate it's active leadership in stewardship for our environment.

Several ideas include:

- Electric vehicle charging stations for staff, patients, and visitors
- Waterless urinals in the bathrooms
- More efficient HVAC systems
- More efficient water systems in the OR and other clinical areas
- Elimination of paper towels in the public bathrooms and installation of air dryers for handwashing
- Elimination of straws (or conversion to compostable straws)
- Implementation of clinical recycling program for clean high-quality plastic and cardboard products
- Consider eliminating (or greatly reducing) disposable plastic eye protection in favor of requiring reusable eye protection (one time purchase of such products for staff could easily be covered by the cost savings of disposable eye protection elimination)
- Encourage the use of re-usable scrub caps to reduce disposable scrub cap use
- Use of motion activated lights in non-clinical and other areas of the medical center that are not in use after hours

2

I am greatly anticipating the improvements that are proposed in the plans that are available for review online. And I am eager to see the ways that you demonstrate commitment to environmental sustainability as you further develop the NW campus.

Robert Yates
General Surgeon
UWMC Montlake and Northwest

RESPONSE TO LETTER 53

Yates, Robert

1. Thank you for your email regarding the UWMC NW campus expansion. UW Medicine is committed to improving the health of the public which includes protecting the environment and minimizing adverse environmental impacts. UW Medicine has a long history of green initiatives and sustainability efforts and is a leading partner with “Practice Greenhealth”, an international healthcare sustainability organization of over 1,400 hospitals and health systems, whose mission is to “is to transform health care worldwide so that it reduces its environmental footprint and becomes an anchor for sustainability and a leader in the global movement for environmental health and justice.”
2. Over the last 7 years, UW Medicine facilities have been recognized 45 times for Practice Greenhealth’s top honors including HMC and UWMC consistently being awarded their highest award of “Top 25 Environmental Excellence” for hospitals that “are leading the industry in all-around sustainability performance, demonstrating comprehensive programs, and illustrating how sustainability is entrenched in their organizational culture.”

UW Medicine has many active initiatives including purchasing “greener” cleaning supplies that have low VOC (cleaner air), use less water, and have less packaging; reducing instrument packaging and blue wrap; expanding the use of reprocessed medical; purchasing EnergyStar labeled equipment; and decreasing the amount of meat and poultry served on-site to reduce associated greenhouse gas emissions. UWMC participates in two facilities energy savings programs: the Seattle Building Tune-Up and the UW Sustainability Action Plan.

As we grow on the Northwest campus, we are committed to taking a sustainable approach to environmental stewardship. UW Medicine recently launched an enterprise-wide Sustainability Coordinating Committee which is charged with developing a health system sustainability strategy, coordinating, and aligning sustainability initiatives, and accelerating UW Medicine's journey to be a leader in the healthcare sustainability field.

We also understand from Louise Simpson, Associate Vice President of Clinical Integration, that you will participate in an upcoming Vizient Go Green Collaborative and serve as a Department of Surgery champion for sustainability initiatives in the operating room.

From: bigswf1@gmail.com
To: northwestmimp@uw.edu
Subject: 120th St traffic
Date: Saturday, September 23, 2023 2:37:46 PM

Hello:

I am writing to you because my concern about what will happen to a quiet street if you open an entrance on North 120th Street. First off, we have no sidewalks available to use. Everyday, there are dog walkers, bike riders, joggers and walkers that get their exercise and/or recreation on this street. If you open this up to more traffic, it will put all who use it at risk. This is a quiet street. When traffic has to be diverted off of Meridian for any reason, it flows down this street, even the buses. There are many families around here and this would put their children at risk. I know that this could be said of anywhere, but when a family buys a home in a quiet, low traffic neighborhood for a safer place for kids to play, it should remain that way.

Thank you for your consideration.

Sent from [Mail](#) for Windows

RESPONSE TO LETTER 54

Anonymous

1. The *2024 MIMP Update* and Final EIS Alternative 3 (Preferred Alternative) identifies N 115th Street as the preferred location for a third driveway.

CHAPTER 5

REFERENCES

- City of Seattle. *City of Seattle Climate Action Plan*:
<https://www.seattle.gov/environment/climate-change/climate-planning/climate-action-plan>. Accessed June 2023.
- City of Seattle. *City of Seattle Comprehensive Plan*. Accessed May 2023.
- City of Seattle. *City of Seattle Department of Neighborhoods Landmarks Website and Map*:
<https://www.seattle.gov/neighborhoods/programs-and-services/historic-preservation/landmarks>. Accessed May 2023.
- City of Seattle. *City of Seattle GIS website*: <http://web1.seattle.gov/dpd/maps/dpdgis.aspx>. Accessed May 2023.
- City of Seattle. *City of Seattle Municipal Code website*:
https://library.municode.com/wa/seattle/codes/municipal_code. Accessed April 2023.
- Northwest Hospital. *Northwest Hospital Major Institution Master Plan*. 1991.
- Northwest Vernacular. *Northwest Hospital Reconnaissance Level Survey*. January 2022.
- The Transpo Group. *UWMC-Northwest MIMP Update Transportation Discipline Report*. August 2023.
- Tree Solutions, Inc. *UWMC-Northwest Tree Survey and Table of Trees*. 2023.
- University of Washington. *UW 2023 Sustainability Action Plan Update*. 2023.
- University of Washington. *Environmental Health and Safety Department Biohazardous Waste Management Plan*. June 2022.
- Washington State Department of Archaeology and Historic Preservation. *Washington Information System for Architectural and Archaeological Records Data*. Accessed May 2023.
- Washington State Department of Ecology. *Washington Air Quality Standards Areas*:
<https://ecology.wa.gov/Regulations-Permits/Plans-policies/Areas-meeting-and-not-meeting-air-standards>. Accessed June 2023.

DISTRIBUTION LIST

Appendix A

UWMC-Northwest MIMP Final EIS Distribution List

Publications

Daily Journal of Commerce
Seattle Times
UW Today

Agencies

Muckleshoot Tribe
Seattle Department of Construction and Inspections
Seattle Department of Neighborhoods
Seattle Department of Transportation
Seattle Fire Department
Seattle City Light
Seattle Public Utilities
Washington Department of Ecology SEPA Center

Community Organizations

UWMC-Northwest Development Advisory Committee (10 member committee representing surrounding neighborhoods)

Libraries

Seattle Libraries – Northgate and Broadview Branches

University of Washington

UW Facilities, Asset Management
UW Facilities, Real Estate
UW Medical Center

All Property Owners within 300 feet of the campus boundary.

All individuals that commented on the Draft EIS.

TRANSPORTATION DISCIPLINE REPORT

FINAL Transportation Discipline Report

UWMC – NORTHWEST MAJOR INSTITUTION MASTER PLAN

Prepared for:
UWMC - Northwest

March 2024

Prepared by:



12131 113th Avenue NE Suite 203
Kirkland, WA 98034-7120
Phone: 425-821-3665
Fax: 425-825-8434
www.transpogroup.com

1.22083.00

© 2024 Transpo Group

Table of Contents

INTRODUCTION.....	1
Alternatives Evaluated	1
Study Approach and Area.....	7
AFFECTED ENVIRONMENT.....	8
Trip Generation	8
Street System	10
Transit Service	10
Non-Motorized Transportation	12
Traffic Volumes	14
Traffic Operations	16
Traffic Safety	17
Loading	18
IMPACTS OF THE NO ACTION ALTERNATIVE	19
Trip Generation	19
Street System	20
Non-Motorized Transportation	21
Transit Service	21
Traffic Volumes	22
Traffic Operations	23
Traffic Safety	28
Loading	28
IMPACTS OF ACTION ALTERNATIVE 1	29
Trip Generation	29
Street System	31
Non-Motorized Transportation	31
Transit	31
Traffic Volumes	33
Traffic Operations	38
Site Access Review	41
Traffic Safety	46
Loading	46
Construction Traffic.....	46
IMPACTS OF ACTION ALTERNATIVE 2	48
IMPACTS OF ACTION ALTERNATIVE 3	49
MITIGATION	50
Intersection Improvements	50
Construction Management Plan (CMP).....	51
SECONDARY AND CUMULATIVE IMPACTS	46
SIGNIFICANT AND UNAVOIDABLE ADVERSE IMPACTS.....	47
NON-MOTORIZED CONNECTIVITY IMPROVEMENTS	48

Appendix

Appendix A Traffic Volumes	Appendix G Signal Warrants
Appendix B Detailed Trip Generation	Appendix H Access Analysis
Appendix C Pipeline Projects	Appendix I Staff Zipcode Maps
Appendix D LOS Definitions	Appendix J Meridian Avenue N/N 115th Street Intersection Vehicle Maneuvers
Appendix E LOS Worksheets	
Appendix F Transit Analysis	

Figures

Figure 1.	No Action Site Plan.....	3
Figure 2.	Alternative 1 Site Plan	4
Figure 3.	Alternative 2 Site Plan	5
Figure 4.	Alternative 3 Site Plan	6
Figure 5.	Site Vicinity & Study Intersections.....	7
Figure 6.	Existing CTR for the Campus	9
Figure 7.	Transit Routes Evaluated and Stop Locations	11
Figure 8.	Existing Pedestrian Facilities.....	13
Figure 9.	Existing Bike Facilities.....	14
Figure 10.	Existing Weekday Peak Hour Traffic Volumes.....	15
Figure 11.	Trip Distribution	24
Figure 12.	No Action Alternative (2030) Weekday Peak Hour Traffic Volumes	25
Figure 13.	No Action Alternative (2040) Weekday Peak Hour Traffic Volumes	26
Figure 14.	Alternative 1 2030 – Interim Buildout Peak Hour Trip Assignment	34
Figure 15.	Alternative 1 2040 – Full Buildout of the MIMP Peak Hour Trip Assignment.....	35
Figure 16.	Alternative 1 2030 – Interim Buildout Weekday Peak Hour Traffic Volumes	36
Figure 17.	Alternative 1 2040 – Full Buildout of the MIMP Weekday Peak Hour Traffic Volumes.....	37
Figure 18.	Alternative 1 2040 Full Buildout of MIMP Access Review Traffic Volumes	44

Tables

Table 1.	Detailed Summary of Development – EIS Alternatives.....	2
Table 2.	Existing Vehicular Trip Generation.....	8
Table 3.	Existing Person Trip Generation (per 2019 CTR)	9
Table 4.	Existing Street Network Summary.....	10
Table 5.	Transit Routes Summary.....	10
Table 6.	Existing Transit Capacity Analysis	12
Table 7.	Existing Peak Hour Level of Service Summary.....	16
Table 8.	Three-Year Collision Summary – 2019 to 2021	17
Table 9.	Loading Berth Survey Building Attributes and Observation Periods	18
Table 10.	Loading Berth Weekday Activity Summary	18
Table 11.	No Action Weekday Vehicle Trip Generation	19
Table 12.	No Action Person Trip Generation	20
Table 13.	No Action (2040) Transit Capacity Analysis	22
Table 14.	Existing and No Action (2030 and 2040) Weekday Peak Hour LOS Summary.....	27
Table 15.	UWMC – Northwest Loading Berth Utilization Study (MIMP)	28
Table 16.	Right Sized Vehicular Trip Generation Rate	29
Table 17.	Alternative 1 Weekday Vehicle Trip Generation	30
Table 18.	Total Alternative 1 Person Trip Generation	30
Table 19.	Alternative 1 Transit Capacity Analysis	31
Table 20.	Alternative 1 Person Trip Generation – Sensitivity.....	32
Table 21.	Alternative 1 Transit Capacity Analysis – Sensitivity.....	33
Table 22.	Alternative 1 (2030) Weekday Peak Hour Off-Site Study Intersections LOS Summary	38
Table 23.	Alternative 1 (2040) Weekday Peak Hour Off-Site Study Intersections LOS Summary	40
Table 24.	Alternative 1 2040 Weekday Peak Hour Site Access LOS Access Summary (Option 1: 3rd access via N 115th St)	42
Table 25.	Alternative 1 2040 Weekday Peak Hour Site Access LOS Access Summary (Option 2: 3rd access via N 120th St)	42
Table 26.	UW Medical Center – Northwest Loading Berth Utilization Study (MIMP).....	46
Table 27.	Meridian Ave N/N 115th St Weekday Peak Hour Mitigation LOS Summary	50

Introduction

This report summarizes the results of the transportation impact analysis conducted evaluating the transportation impacts of the proposed UWMC – Northwest Major Institution Master Plan (MIMP). This report is organized into the following sections:

Introduction – This section outlines project alternatives, the overall approach and scope, and provides the methodology of the transportation analysis completed for the project.

Affected Environment – This section documents the existing transportation conditions within the study area defined for this analysis.

Impacts of No Action Alternative – This section describes the No Action transportation conditions within the study area defined for this analysis.

Impacts of Action Alternative 1– This section describes the impacts of Action Alternative 1. Transportation impacts are identified through a comparison of Alternative 1 to the No Action Alternative.

Impacts of Action Alternative 2– This section describes the impacts of Action Alternative 2 on the transportation elements noted above. Transportation impacts are identified through a comparison of Alternative 2 to the No Action Alternative.

Impacts of Action Alternative 3– This section describes the impacts of Action Alternative 3 on the transportation elements noted above. Transportation impacts are identified through a comparison of Alternative 3 to the No Action Alternative.

Mitigation – This section describes the potential transportation mitigation measures to mitigate Alternative-related impacts.

Secondary and Cumulative Impacts – This section describes secondary and cumulative impacts that could occur with development of the project.

Significant and Unavoidable Adverse Impacts – This section documents adverse transportation-related impacts that could not be fully mitigated with the Alternatives.

Non-Motorized Connectivity Improvements – This section describes planned non-motorized connectivity.

Alternatives Evaluated

Three alternatives are evaluated in this DRAFT Environmental Impact Statement (DEIS), including one (1) No Action Alternative and two (2) development alternatives. The Alternatives include:

- **No Action Alternative** – Includes the development to date including the existing 549,697 gross square feet (gsf) medical center as well as the Behavior Health Training Facility (BHTF) which will construct an additional 188,846 gsf (3035557-LU/6757676-CN). An additional 26,000 gsf of development was assumed as the remaining balance of development under the current MIMP. This results in a total No Action size of 764,543 gsf. Parking for the No Action condition includes the existing 1,605 on-site parking stalls as well as the net increase of 28 stalls associated with the BHTF project for a total of 1,633 on-site parking stalls. No increase in parking was assumed as part of the 26,000 gsf of reminding development in the MIMP. The two (2) existing access points that exist along N 115th Street will be maintained under the No Action Alternative.
- **Action Alternative 1** – Assumes a campus total of up to 1,600,000 gsf, equating to development of up to 835,457 gsf. For purposes of the traffic analysis, a total of 800,000 gsf was assumed to be developed by 2030, with the remaining completed by 2040. The campus parking supply for Alternative 1 will be provided per the MIMP development standards which identifies a maximum supply estimated to be up to 3,300 stalls assuming the campus's current SOV goal of 65 percent for employees. Two options for an additional campus access point were evaluated under the MIMP. Access options evaluated for Alternative 1 include maintaining the two (2) existing access

points along N 115th Street and providing a third access point via either N 115th Street or N 120th Street. Additionally, as the location of the on-site parking supply has not been fully defined within the MIMP as it is dependent on where development on the campus occurs, the distribution of parking is evaluated for each access option considering a scenario that has parking (a) equally distributed or (b) concentrated to the west side of the campus.

- **Action Alternative 2** – The development size, timing, site access, and parking for Alternative 2 are consistent with Alternative 1 with changes limited to building heights, massing, etc. Since there are no changes in the overall development plan or potential access point locations, no additional analysis for this alternative was conducted.
- **Action Alternative 3 (Preferred)** – The development size, timing, and parking for Alternative 3 are consistent with Alternatives 1 and 2. Compared to Alternatives 1 and 2, Alternative 3 provides updated building height overlays (a reduction in height in the north portion of the campus) and wider perimeter building setback areas. Additionally, Alternative 3 identifies the third access drive as being from N 115th Street only and does not include an option of a third access from N 120th Street as was assumed under Alternatives 1 and 2.

The summary of development for the Alternatives is summarized in Table 1. The site plans for the No Action and Action Alternatives are included in Tables 1 through 3.

Table 1. Detailed Summary of Development – EIS Alternatives

Condition	No Action	Alternatives 1, 2, & 3
Existing	549,697 gsf	549,697 gsf
Behavior Health Training Facility (BHTF)	188,846 gsf	188,846 gsf
Additional Development under the current MIMP	26,000 gsf	26,000 gsf
Additional Development Area with MIMP (2030 & 2040)		835,457 gsf
		<i>By 2030</i>
		<i>800,000 gsf</i>
		<i>Additional by 2040</i>
		<i>35,457 gsf</i>
Total Development Size of Alternative	764,543 gsf	1,600,000 gsf

Notes: gsf = gross square feet. Shading shows potential timing of development of the additional development area with MIMP.

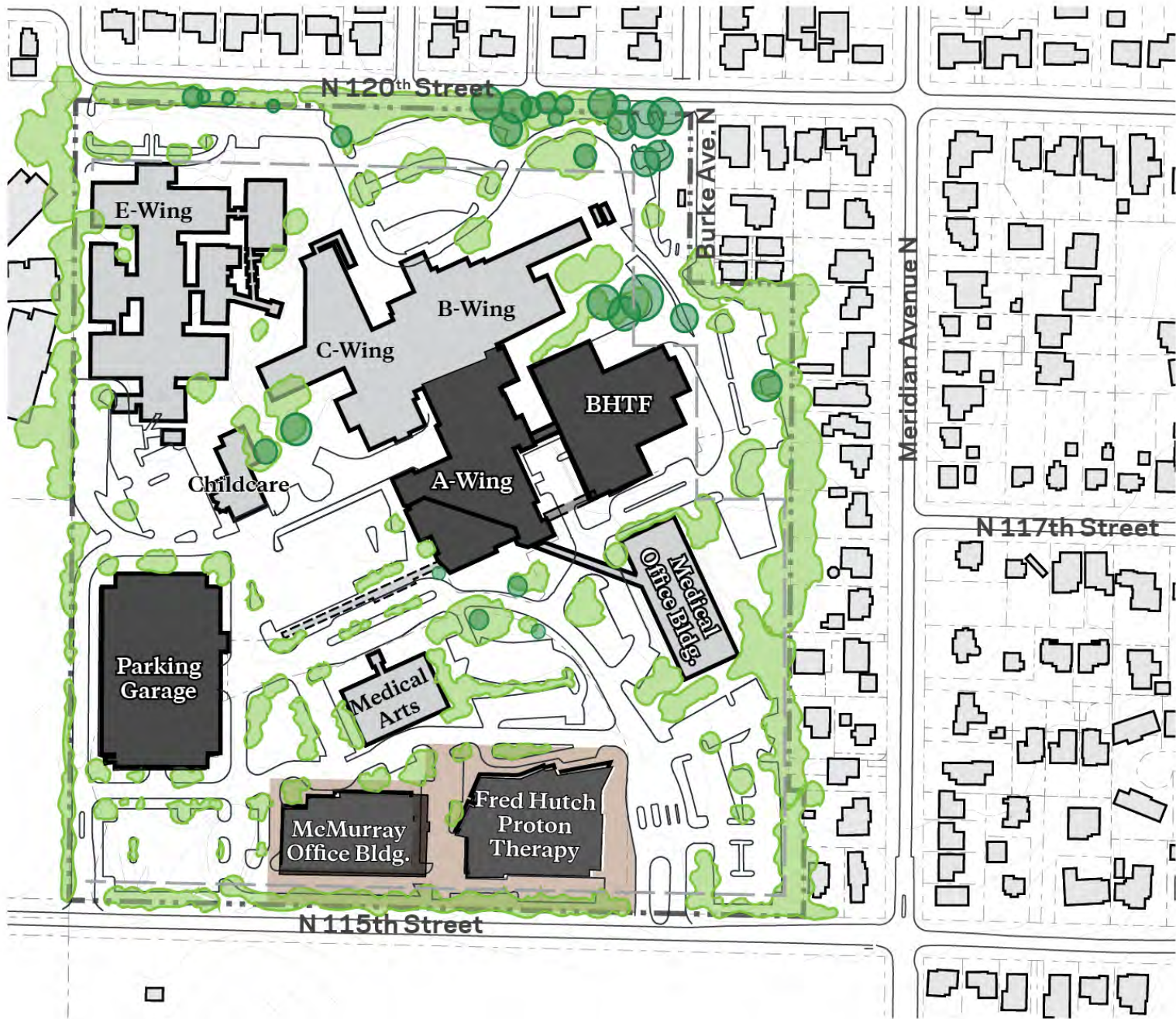

No Action Site Plan

UWMC NW TDR

FIGURE

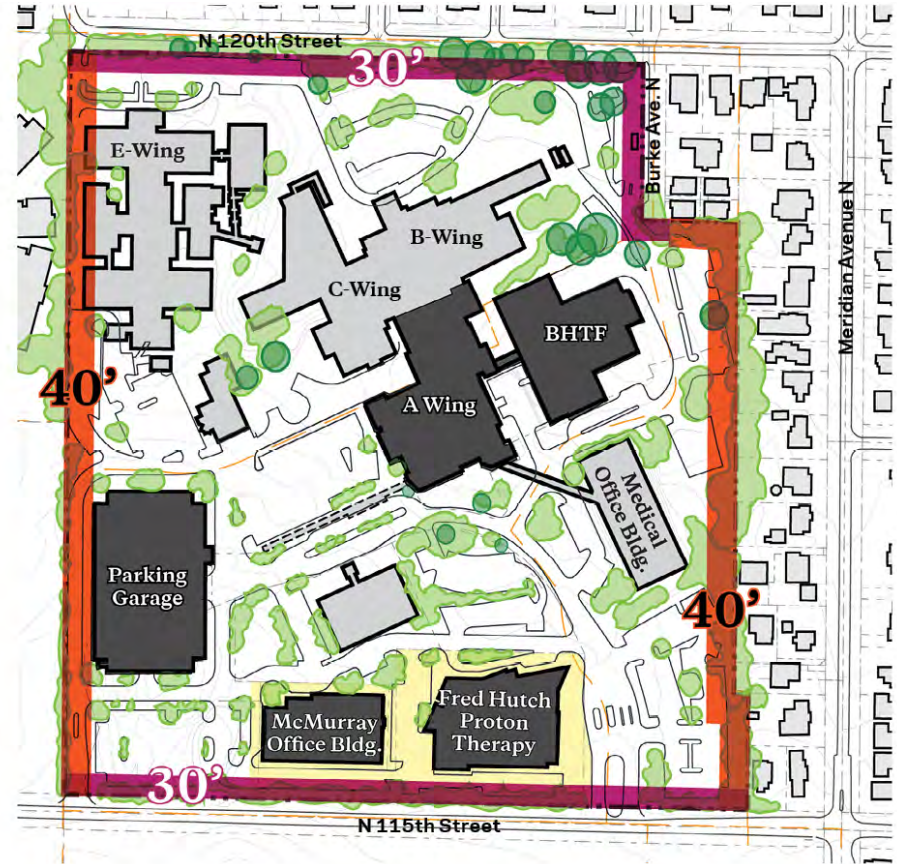
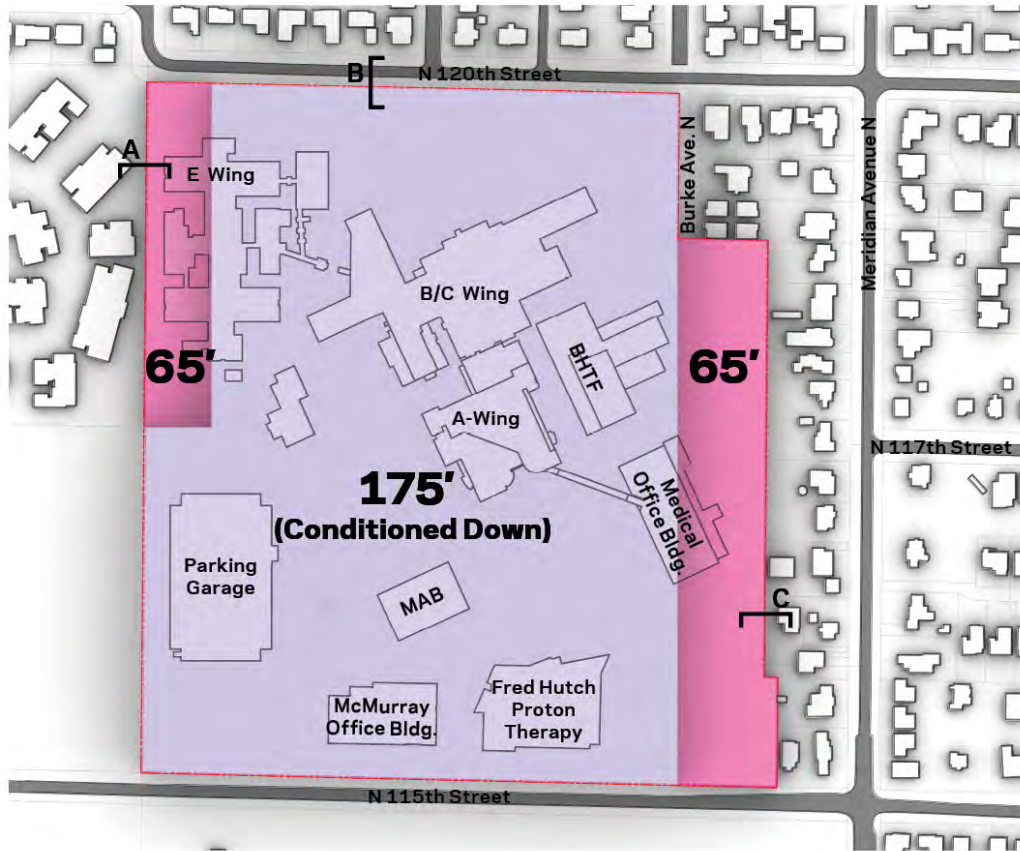

Alternative 1 Site Plan

UWMC NW TDR

FIGURE

2

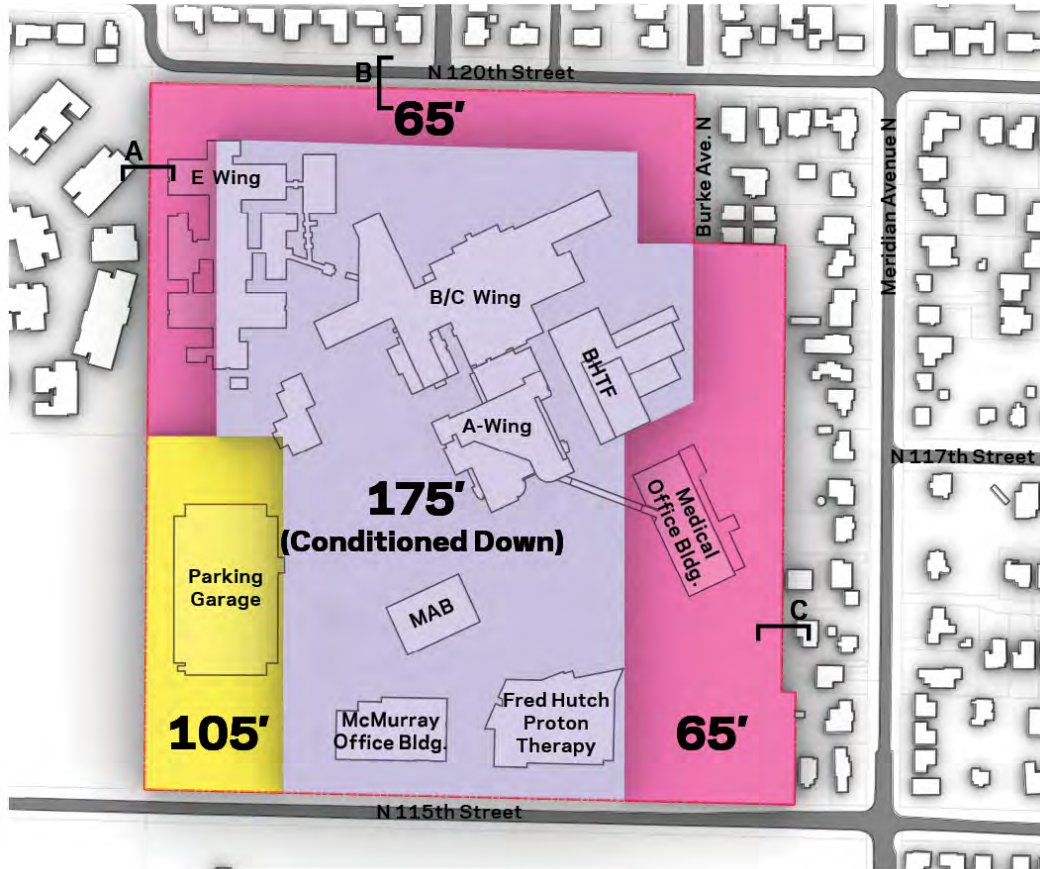

Alternative 2 Site Plan

UWMC NW TDR

FIGURE

3



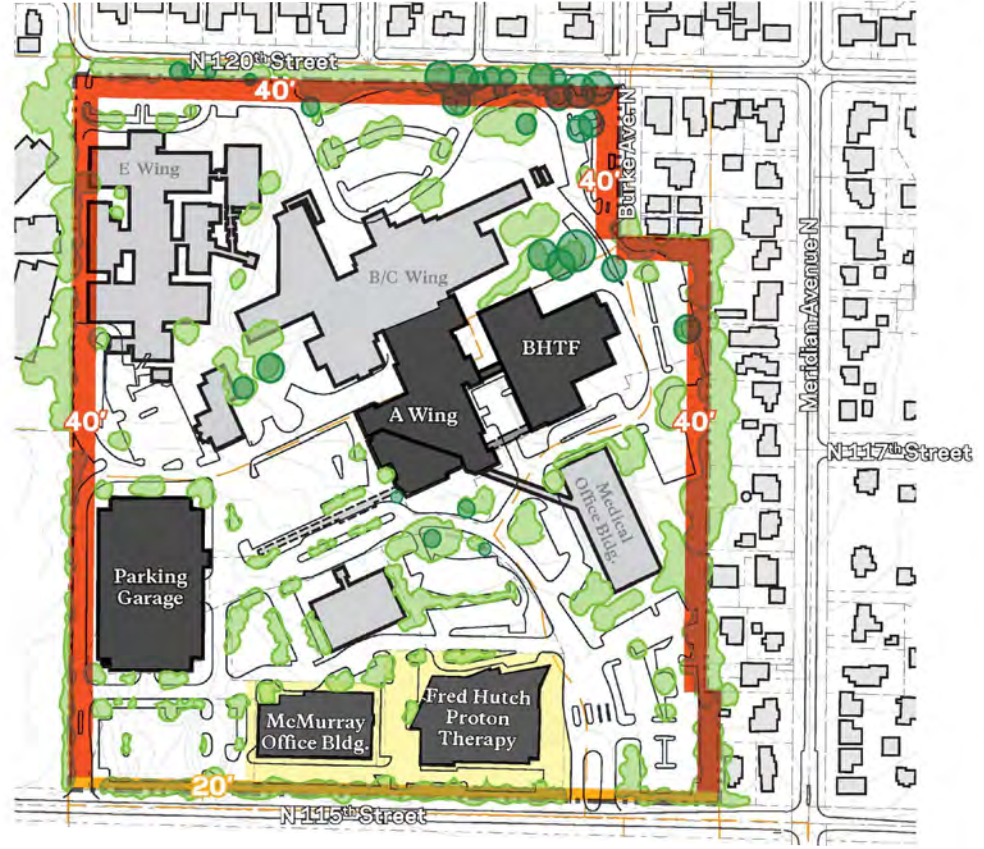

Alternative 3 Site Plan

UWMC NW TDR

FIGURE

4



Study Approach and Area

The scope of the transportation analysis conducted for the DEIS was coordinated with staff from the Seattle Department of Construction and Inspections (SDCI) and the Seattle Department of Transportation (SDOT). The following transportation elements were evaluated, and results are summarized in this report:

- **Trip Generation** – The basis of the existing, No Action, and Alternatives trip generation for UWMC is existing traffic counts conducted for the existing campus during the weekday AM and PM peak periods with the exception of the trip generation of the BHTF which is assumed consistent with the previous study completed for that development. Adjustments to the trip generation rates for the Action Alternatives accounting for right-sizing the hospital spaces was included in the analysis.
- **Street System** – The existing and future planned street system are identified. Alternative impacts to the street system are evaluated based on potential changes to the nearby street network connectivity.
- **Non-Motorized Transportation** – The existing and future pedestrian and bicycle system surrounding the site is evaluated. The number of non-motorized trips are estimated for the Alternatives and any impacts associated with those trips are reviewed.
- **Transit Service** – The transit service of transit near the campus is reviewed including frequency, service area, proximity, and capacity. Future investments in the local transit system have been identified. Alternative impacts to the transit capacity are evaluated based on the estimated number of transit trips.
- **Traffic Volumes** – Existing traffic volumes were collected at the study intersections in January 2023 and July 2023 during both the weekday AM (7-9 a.m.) and PM (4-6 p.m.) peak periods. Future (2030 and 2040) forecast traffic volumes for the No Action conditions are comprised of the existing traffic volumes, background traffic growth, traffic generated from the planned “pipeline” developments, and the trips associated with the No Action allowable development (see Table 1). Action Alternatives traffic volumes were then estimated by adding the trip generation for the Action Alternatives to the No Action volumes.
- **Traffic Operations** – The traffic operations are evaluated at the study intersections based on level of service (LOS) relative to the existing and forecast traffic volumes of each Alternative.
- **Traffic Safety** - Recent collision records are reviewed within the study area to identify existing traffic safety issues at the study intersections. Future traffic impacts are reviewed relative to existing collision history patterns and forecast growth of movements.
- **Site Loading** – The capacity of the loading docks are evaluated based on the planned number of loading docks and overall demand associated with the 1.6 M gsf identified in the MIMP.

The transportation analysis included an evaluation of two future horizon years: 2030 and 2040. Based on the net new trip generation estimated for the Action Alternatives, trip distribution assumptions, and coordination with SDCI and SDOT staff, 12 off-site study intersections were identified to be evaluated during the weekday AM and PM peak hours.

- | | |
|--|---|
| 1. Aurora Ave N/N 130th St | 7. I-5 SB Ramps/Corliss Ave N/N Northgate Way |
| 2. 1st Avenue NE/N 130th St | 8. I-5 NB Ramp/1st Avenue NE/N Northgate Way |
| 3. Aurora Avenue N/N 115th St | 9. 1st Ave NE/I-5 Northbound Ramp/NE 107th St |
| 4. Meridian Avenue N/N 115th St | 10. Meridian Ave N/N 120th St |
| 5. Aurora Ave N/N 105th St/N Northgate Way | 11. 1st Avenue NE/N 117th St |
| 6. Meridian Ave N/Northgate Way | 12. Aurora Avenue N/N 125th St |

The study intersections are shown on Figure 5. Note that in addition to the off-site study intersections, the existing and future access points were evaluated as well.

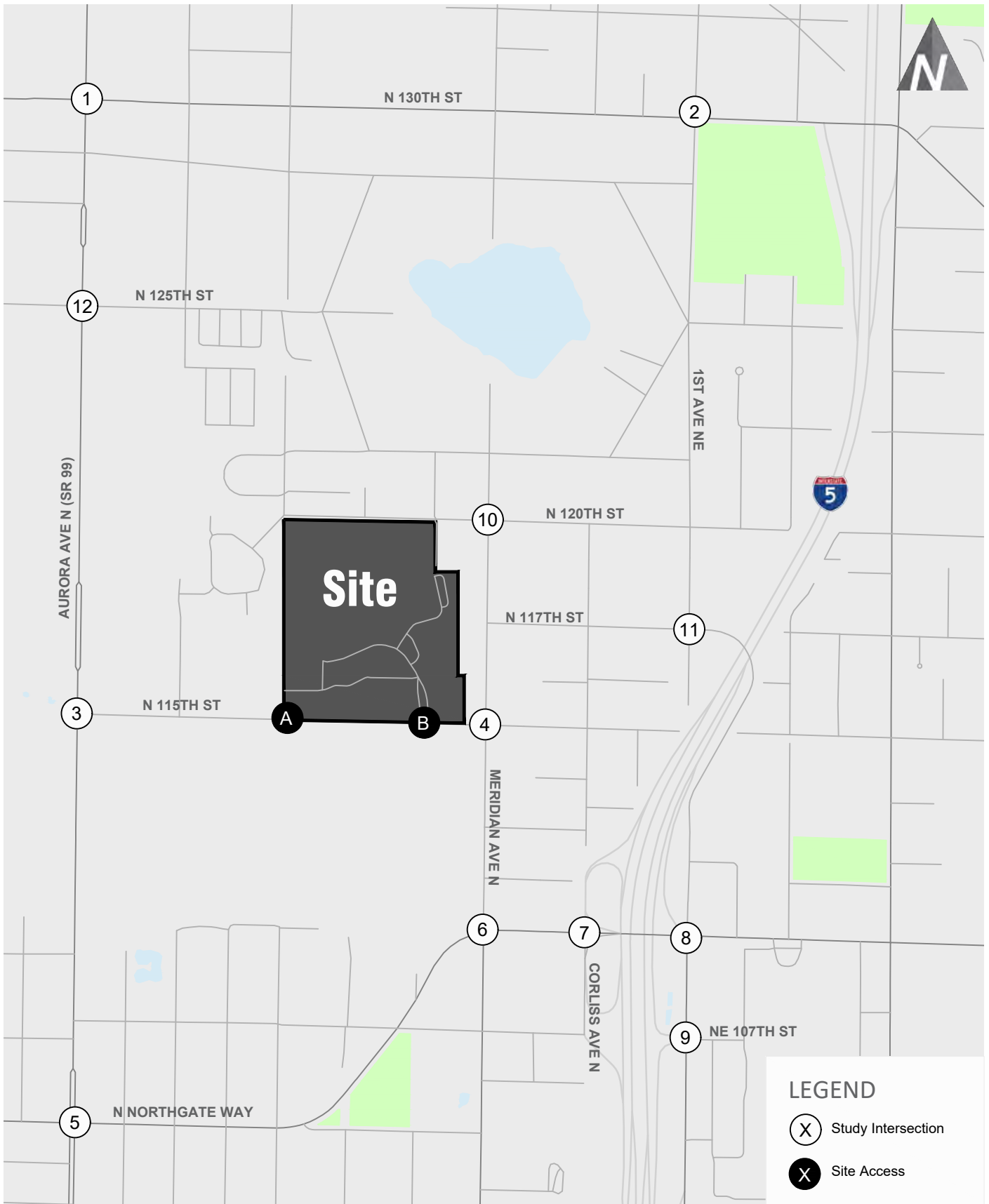

Site Vicinity and Study Intersections

FIGURE

UWMC NW TDR



5

Affected Environment

This section provides an overview of the existing conditions within the defined study area. The existing transportation system including trip generation, street system, transit service, non-motorized transportation, traffic volumes, traffic operations, traffic safety and loading are described below.

Trip Generation

Weekday AM and PM peak hour trip generation for the campus was estimated based on traffic volumes collected for two (2) midweek-days in May 2022 during the weekday AM (7-9 a.m.) and PM (4-6 p.m.) peak periods at the access points as well as observations of on-street parking along the campus N 115th Street frontage. The existing trip generation¹ of the site as observed during the counts is 606 and 516 during the AM and PM peak hours, respectively. The detailed counts are provided in Appendix A.

Table 2. Existing Vehicular Trip Generation

	Existing Size	Weekday Daily	Weekday AM Peak Hour			Weekday PM Peak Hour		
			In	Out	Total	In	Out	Total
<i>Tuesday, May 10, 2022</i>			389	189	578	92	354	446
<i>Wednesday, May 11, 2022</i>			365	178	543	74	327	401
Average Existing Access Point Trips ¹	549,697 gsf		377	184	561	83	341	424
Trips along N 115th Street			30	15	45	30	62	92
Total Existing Trips		7,300⁴	407	199	606	113	403	516
Existing Rate (Trips/1,000 gsf)		13.20⁴			1.10			0.94
ITE Rate (Trips/1,000 gsf)²								
<i>Hospital (610)</i>		<i>10.77</i>			<i>0.82</i>			<i>0.86</i>
<i>Medical-Dental near Hospital (720)</i>		<i>31.86</i>			<i>2.68</i>			<i>2.84</i>
ITE Weighted average³		18.15			1.47			1.55

Note: sf = square feet

- Counts conducted from 7-9 a.m. and 4-6 p.m. for the 2 midweek days.
- Rates per Institute of Transportation Engineers (ITE) *Trip Generation Manual* (11th Edition, 2021).
- Weighted average assumes the existing allocation of hospital and medical office of approximately 65 percent and 35 percent, respectively.
- Existing daily trip generation rate and trips estimated by comparing the ITE rates in the AM peak hour to the daily for the hospital, medical-dental, and weighted average rates. The comparison showed the daily was approximately 12 times the AM peak hour which was assumed for the campus. AM was assumed as the observations showed that was the greater trip generator for the campus of the 2 peak periods.

The existing site trip generation rate was calculated by dividing the average weekday AM and PM peak hour access point trips by the existing site development area of 549,697 gsf. The resulting weekday AM and PM peak rates are 1.10 and 0.94 trips per 1,000 square feet, respectively. The summary of the existing counts and resulting rates is provided in Table 2. The detailed trip generation calculations are provided in Appendix B.

The observed vehicular trip generation for the campus were also compared to standard rates provided in the Institute of Transportation Engineers (ITE) *Trip Generation Manual* (11th Edition, 2021) for the two existing uses on campus including Hospital (LU 610) and Medical-Dental on Hospital campus (LU 720). These rates are summarized in Table 2 for comparison along with a weighted average rate based on the current split of uses. Comparing the observed rates to the weighted average ITE rate for the campus, the AM and PM peak hour observed trip generation rates are approximately 25 percent and 40 percent less than of the ITE rates, respectively. Although the existing data collected is less than ITE, ITE recommends the use of existing data when available, thus the local data was utilized. Additionally, the ITE rates were used to estimate the weekday daily trips for the campus, which were estimated to be approximately 7,300 trips.

Trip generation reflected in the counts represent a combination of UWMC – Northwest staff, visitors and patients to the campus, clinic staff and patients, and service vehicles and deliveries to the campus. Based

¹ Represented by the average of the two-day counts.

on data collection means and methods, it is not feasible to separate out the individual user groups in the existing data. The Commute Trip Reduction (CTR) survey conducted for campus staff identifies mode-split information including the number of trips associated with vehicles, non-motorized, transit, etc. The CTR data indicates a high vehicle SOV mode share. Although the CTR is specific to employees of the campus and trip generation encompasses all trips, the CTR is applied to the entire campus population. Given the nature of the visitors to campus and users of the medical care provided, it is unlikely that much of that population accesses the campus via means not related to a vehicle trip.

The most recent CTR study completed for the campus (2019)² showed 75 percent of the employee trips to/from the site were single occupancy vehicle (SOV) with an additional 14 percent associated with carpool and vanpool trips resulting in an average vehicle occupancy (AVO) of 1.1 (see Figure 6). Additionally, transit trips accounted for approximately 7 percent of the trips to/from the campus with the remaining 4 percent of trips associated with non-motorized trips (i.e. walking, biking, telework, other). The mode share distribution per the existing CTR corresponds with the staff residences, which are dispersed throughout the region (see Appendix I showing staff zip code data).

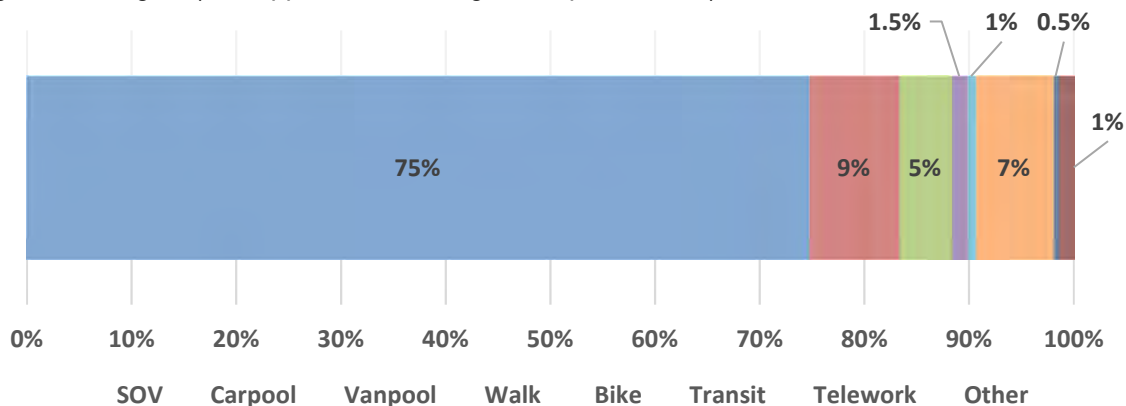

Figure 6. Existing CTR for the Campus

The total person trip generation for the campus was estimated for the peak hours including the estimation of transit and non-motorized trips based on applying the existing CTR trip type distribution and AVO estimates to the vehicular trip generation. The estimated existing person trip generation is summarized in Table 3.

Table 3. Existing Person Trip Generation (per 2019 CTR)

Trip Generation	Mode Split	Weekday AM Peak Hour			Weekday PM Peak Hour		
		In	Out	Total	In	Out	Total
Existing Vehicle Trips (75% SOV)¹		407	199	606	113	403	516
Person Trips							
Walk and Bike Trips	2.5%	13	6	19	4	13	16
Transit Trips	7%	35	17	53	10	35	45
Other	1.5%	8	4	11	1	8	10
Person Trips by Vehicle ¹	<u>89%</u>	<u>451</u>	<u>220</u>	<u>671</u>	<u>125</u>	<u>446</u>	<u>571</u>
Total Person Trips	100%	507	247	754	140	502	642

1. The 89 percent person trips by vehicle includes approximately 75 percent SOV and 14 percent associated with carpool and vanpool trips, resulting in a AVO of 1.1. The AVO of 1.1 was multiplied by the vehicles trips to determine the number of person trips by vehicle. The person trip distribution per the CTR was then applied to determine the total person trips.

As shown in Table 3, there are estimated to be 53 and 45 transit trips in the AM and PM peak hours, respectively and 19 and 16 non-motorized trips (walk, bike) in the AM and PM peak hours, respectively.

² The 2019 data is the most recent completed CTR survey for the campus.

Street System

The campus is bounded to the south by N 115th Street, (a collector arterial) and to the north by N 120th Street (a non-arterial roadway). North/south connectivity near the site is provided by Meridian Avenue N (a collector arterial) located in close proximity east of the site as well as further to the west of the site via Aurora Avenue N (a principal arterial). Additional characteristics of the existing street network in the proposed project vicinity are shown in Table 4.

Table 4. Existing Street Network Summary

Roadway	Arterial Classification ¹	Posted Speed Limit	Number of Travel Lanes	Parking?	Sidewalks?	Bicycle Facilities?
Aurora Avenue N	Principal Arterial	40 mph ²	6-7	No	Intermittent	No
N Northgate Way	Principal Arterial	30 mph	4	No	Yes	No
Meridian Avenue N	Collector Arterial	25 mph	2	Yes ³	Yes	Yes ⁴
N 115th Street	Collector Arterial	25 mph	2	Yes	Yes ⁵	No
N 117th Street	Non-Arterial	25 mph	2	Yes	No	No
N 120th Street	Non-Arterial	25 mph	2	Yes	Yes ⁶	No
N 125th Street	Collector Arterial	25 mph	2	No	Yes	Yes
N 130th Street	Principal Arterial	30 mph	4	No	Yes	No
1st Avenue NE	Collector Arterial	30 mph	2 - 4 ⁷	Yes ⁸	Yes ⁹	Yes ¹⁰

1. Based on the Seattle Arterial Classification Map.
2. Posted speed limit of 40 mph north of N 115th Street and 35 mph south of N 115th Street.
3. Time restricted parking is only available on the west side between N 122nd Street and N 115th Street.
4. Provided only south of N Northgate Way.
5. Provided only on the north side between Aurora Avenue N and Meridian Avenue N.
6. Provided only on the south side between 1st Avenue NE and Corliss Ave N.
7. Two travel lanes present north of I-5.
8. Provided only on the east side between NE Northgate Way and NE 112th St, and intermittent north of N 117th St.
9. Provided on the east side only south of N 117th St, and west side only north of N 117th St.
10. Provided only north of NE 115th St and south of NE 103rd St.

Transit Service

Transit service in the study area is provided by King County Metro. The nearest bus stop to the campus is located on campus, north of the eastern site access. Outside of the medical center, the nearest bus stops are located approximately 350 feet east of the site entrance at the Meridian Avenue N/N 115th Street intersection. Local transit routes with stops within the vicinity of the project site are shown in Figure 7.

A summary of the routes, headways, and hours of operation are summarized in Table 5.

Table 5. Transit Routes Summary

Route	Days of Operation	Hours of Operation		Headway ¹
		Weekdays	Weekends	
40 – Northgate TC to Crown Hill to Ballard to Downtown Seattle	Mon-Sun	5:00 a.m. – 2:00 a.m.	6:00 a.m. – 1:50 a.m.	15-30
345 – Shoreline Community College to Northgate TC to Downtown Seattle	Mon-Sun	6:30 a.m.-11:30 p.m.	Sat: 7:30 a.m.-9:00 p.m. Sun: 6:00 a.m.-11:00 p.m.	25-30
346 (with 41) – Aurora Village TC to Northgate TC to Downtown Seattle	Mon-Sun	5:30 a.m.-11:15 p.m.	Sat: 6:15 a.m.-11:15 p.m. Sun: 6:45 a.m.-11:45 p.m.	30
RapidRide E-Line – Aurora Village to Downtown Seattle	Mon-Sun	4:30 a.m.-3:45 a.m.	Sat: 4:50 a.m.-3:45 a.m. Sun: 4:50 a.m.-3:45 a.m.	5-10

Source: King County Metro (March 2023)

1. Headways in minutes during weekday AM and PM Peak periods.



Figure 7. Transit Routes Evaluated and Stop Locations

Further from the site, Sound Transit’s Northgate Link Light Rail Station is located approximately 1 mile southeast from the site between NE 103rd Street and NE 100th Street. The Light Rail provides service to Downtown Seattle, Capitol Hill, the University of Washington, and SeaTac Airport. Note that Routes 345 and 346 with stops in close proximity to the campus provide service to the Northgate Station.

Existing transit demand is estimated based on the average weekday AM and PM peak periods ridership Fall 2022 data provided by King County Metro.³ As summarized in Table 3 above, there are estimated to be 49 and 37 transit trips in the AM and PM peak hours, respectively, which would be captured in the Fall 2022 ridership data provided. The typical vehicle type for each route and capacity of the vehicle was also provided in the Fall 2022 data.

Four routes were analyzed around the campus to assess how weekday transit capacity compares to transit demand. Each route is evaluated by direction for the weekday AM and PM peak hour. Using the vehicle capacity identified in the Fall 2022 data for each route and applying the frequency of service (trips per peak period) for the weekday AM and PM peak periods, transit capacities per peak period were defined for each route.

The total available capacity and ridership for each route is summarized in Table 6 for the weekday peak periods. The detailed calculations are included in Appendix F. As shown in the table, the utilization on the buses surrounding campus range between 8 and 31 percent, such that all of the routes serving the campus have remaining capacity to accommodate additional riders during the weekday peak periods.

³ The peak periods for the transit analysis are assumed to be 5-9 a.m. and 3-7 p.m.

Table 6. Existing Transit Capacity Analysis

Route # / Nearest Stop Location	Direction of Travel	AM Peak Period			PM Peak Period		
		Capacity ¹	Ridership ¹	Utilization	Capacity ¹	Ridership ¹	Utilization
345 On Campus, north of eastern access point	S	296	45	15%	444	84	19%
	N	296	54	18%	407	101	25%
346 At the Meridian Avenue N/N 115th Street Intersection	S	370	77	21%	407	102	25%
	N	333	77	23%	370	114	31%
40 At the SR 99/N 115th Street Intersection	S	1,520	116	8%	1,672	255	15%
	N	988	126	13%	1,672	202	12%
E Line At the SR 99/N 115th Street Intersection	N	1,404	355	25%	2,808	727	26%
	S	2,496	550	22%	2,028	546	27%

1. Based on bus frequencies, ridership, and typical capacity data provided by King County Metro for Fall 2022.

Non-Motorized Transportation

All arterial streets in the project vicinity provide sidewalks on one or both sides of the roadway. Marked crosswalks and curb ramps exist at the adjacent Meridian Avenue N/N 115th Street all-way stop controlled intersection as well as at all signalized study intersections. The existing pedestrian facilities include complete connections to all transit routes located within the vicinity of the site as described in the transit section above and shown in Figure 8. The connections to each route include:

- **Route 345** – The nearest stop is located on-campus accessed via the eastern access point. There are sidewalks and crosswalks provided throughout campus connecting to the transit stop.
- **Route 346** – The nearest stops are located along Meridian Avenue N, north and south of N 115th Street. Sidewalks are provided along the north side of N 115th Street, connecting to the crosswalk at the Meridian Avenue N all way stop controlled intersection with sidewalk along Meridian Avenue N connecting to both directional stops.
- **Route 40** – The nearest stops are located along N Northgate Way, west of Meridian Avenue N. Sidewalks are provided along the north side of N 115th Street, connecting to the crosswalk at the Meridian Avenue N all way stop controlled intersection. Sidewalks are provided along Meridian Avenue N and N Northgate Way connecting to both directional stops with a signalized crossing provided at the Meridian Avenue N/N Northgate Way intersection.
- **E Line** – The nearest stops are located along Aurora Avenue N, north and south of N 115th Street. Sidewalks are provided along the north side of N 115th Street, connecting to the signalized crossing at the Aurora Avenue N intersection with sidewalk along Aurora Avenue N connecting to both directional stops.
- **Link Light Rail Station** – Although further from the site (greater than 1 mile walking), there are continuous sidewalk connections from the site along Meridian Avenue N then connecting to the south via the John Lewis Memorial Bridge.

Bicycle facilities within the vicinity of the project include a signed bike route along Meridian Avenue N, located east of the site which connects to sharrows to the north along N 125th Street and a protected bike lane south of N Northgate Way (see Figure 9).

Additionally, the Interurban Trail is located west of Aurora Avenue N which is a 24-mile multipurpose trail running from Seattle to Everett.

As reported in the campus’s most recent (2019) CTR study, pedestrian and bicycle percentages of approximately 2 percent and 1 percent of employee trips. Given the site being a hospital and discussed above, it is assumed that most patients would similarly have lower non-motorized percentage. These percentages are estimated to equate to approximately 17 and 13 non-motorized trips during the weekday AM and PM peak hours, respectively.

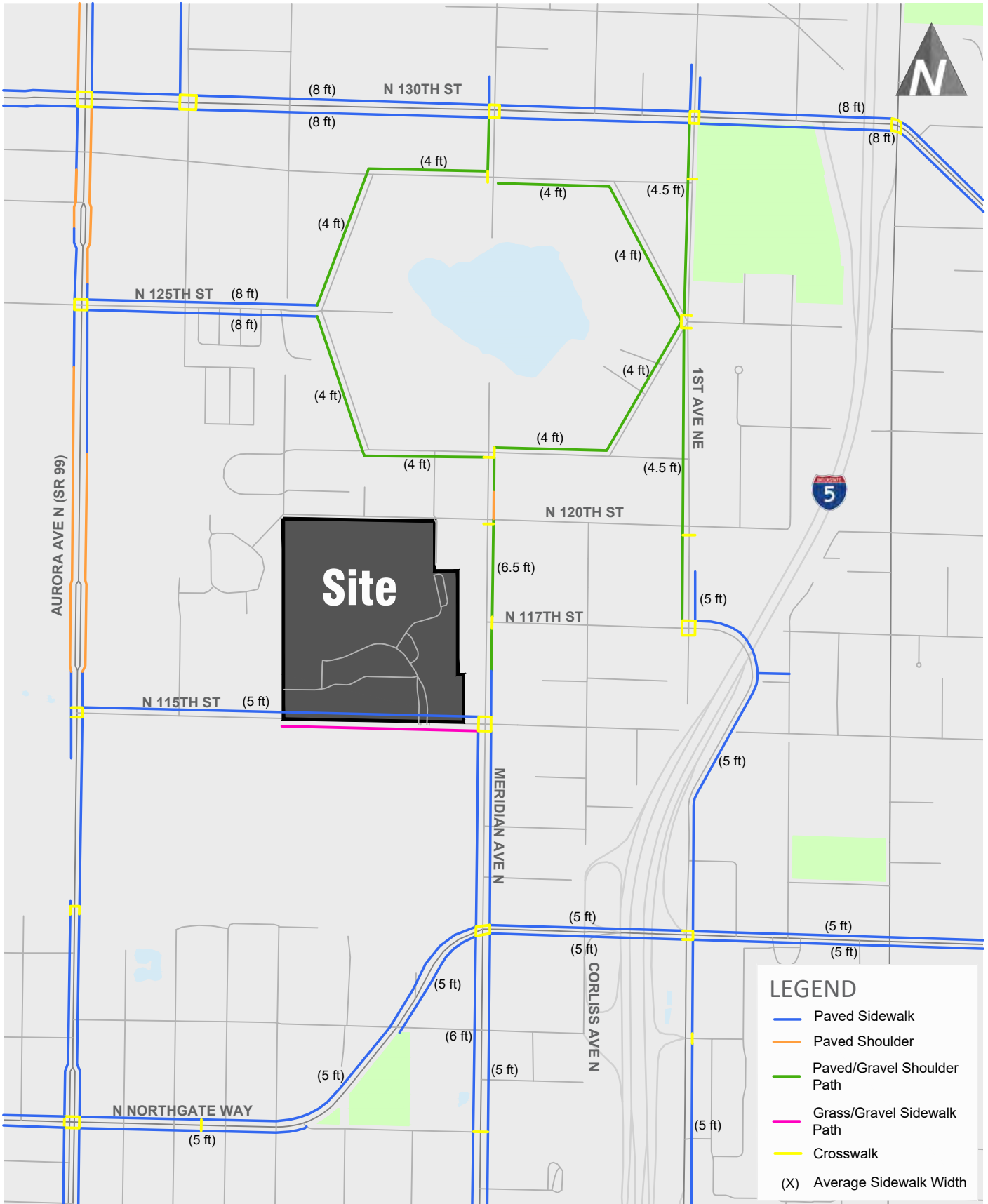

Existing Pedestrian Facilities

UWMC NW EIS



FIGURE 8

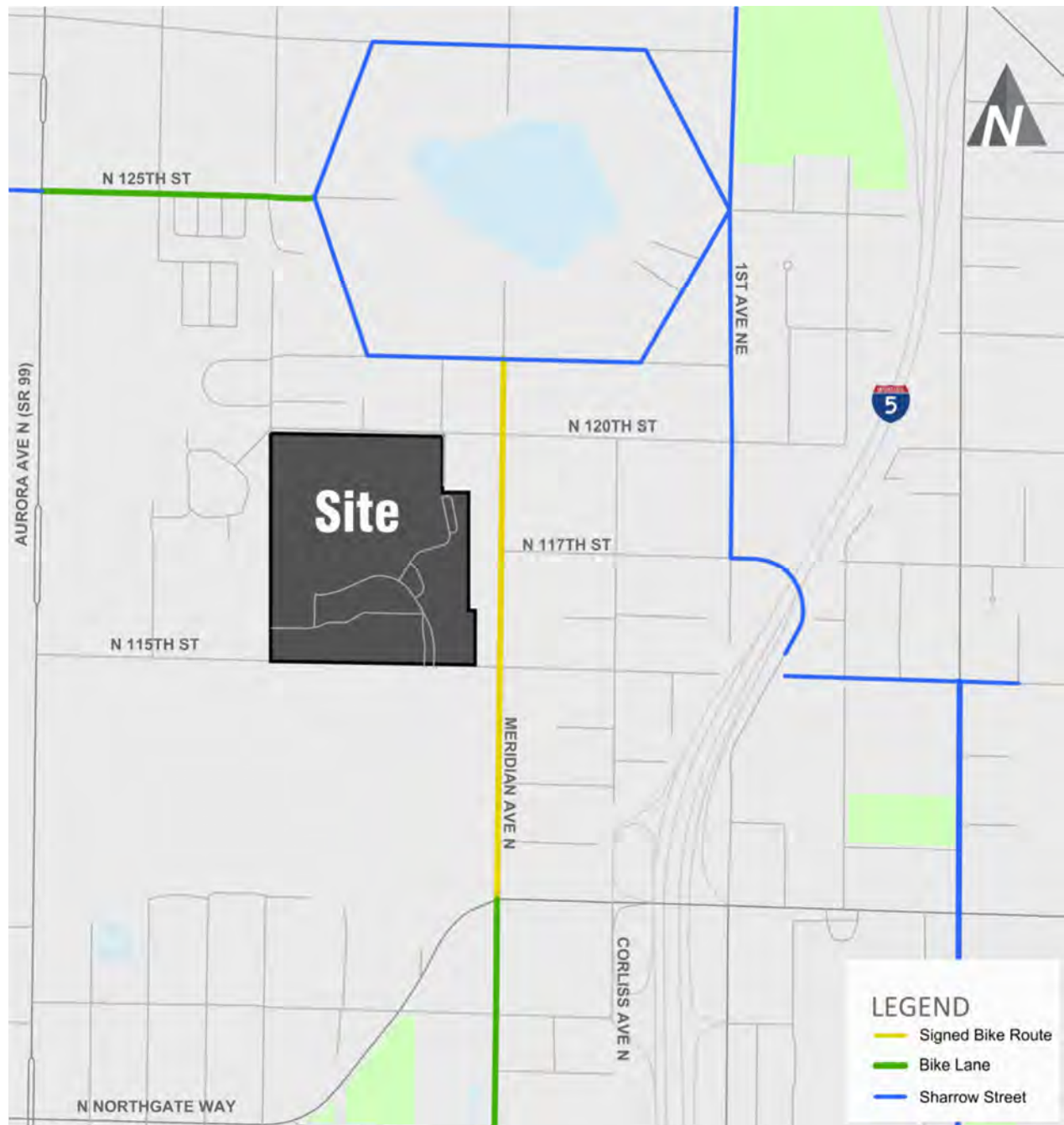
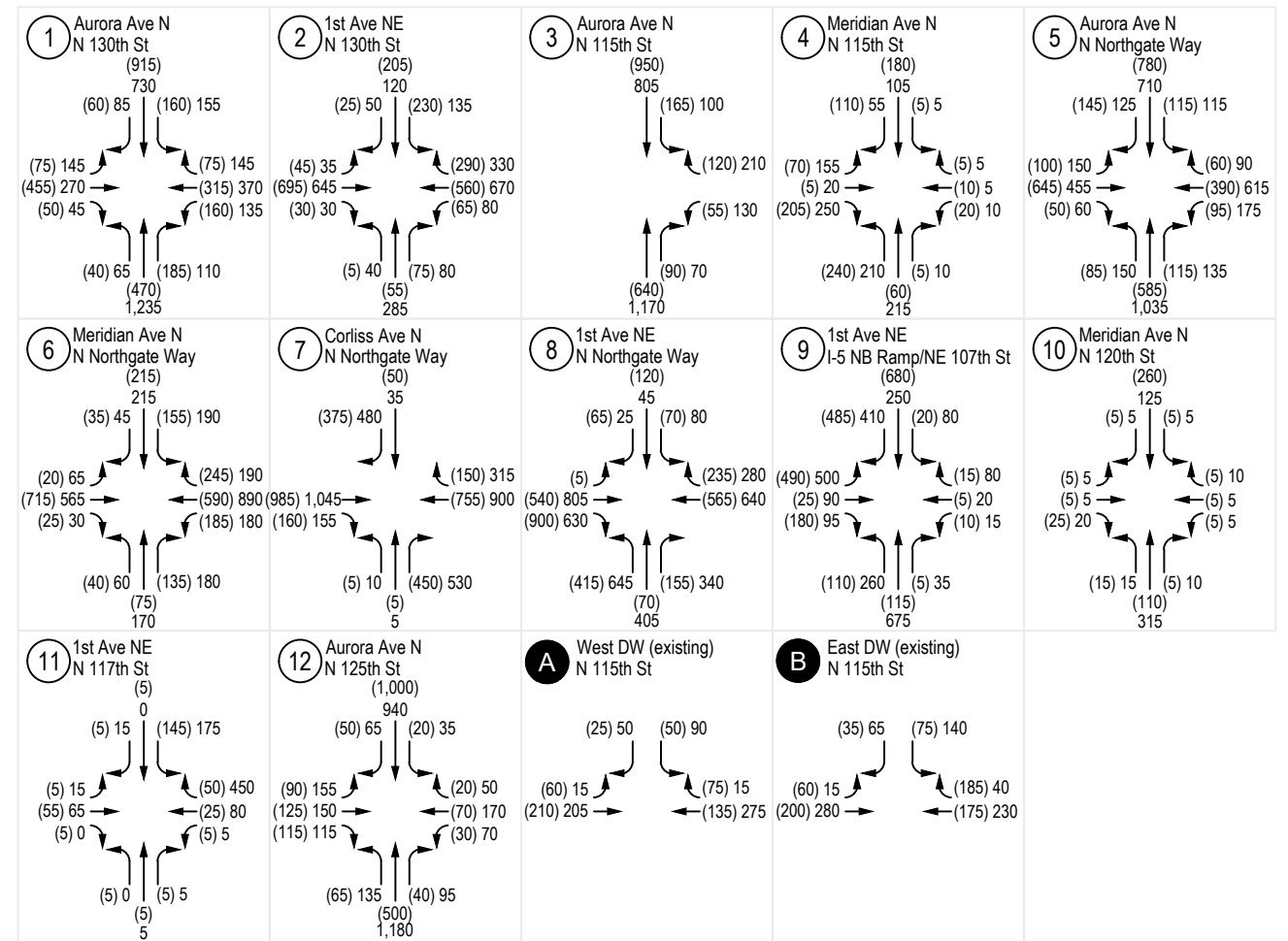
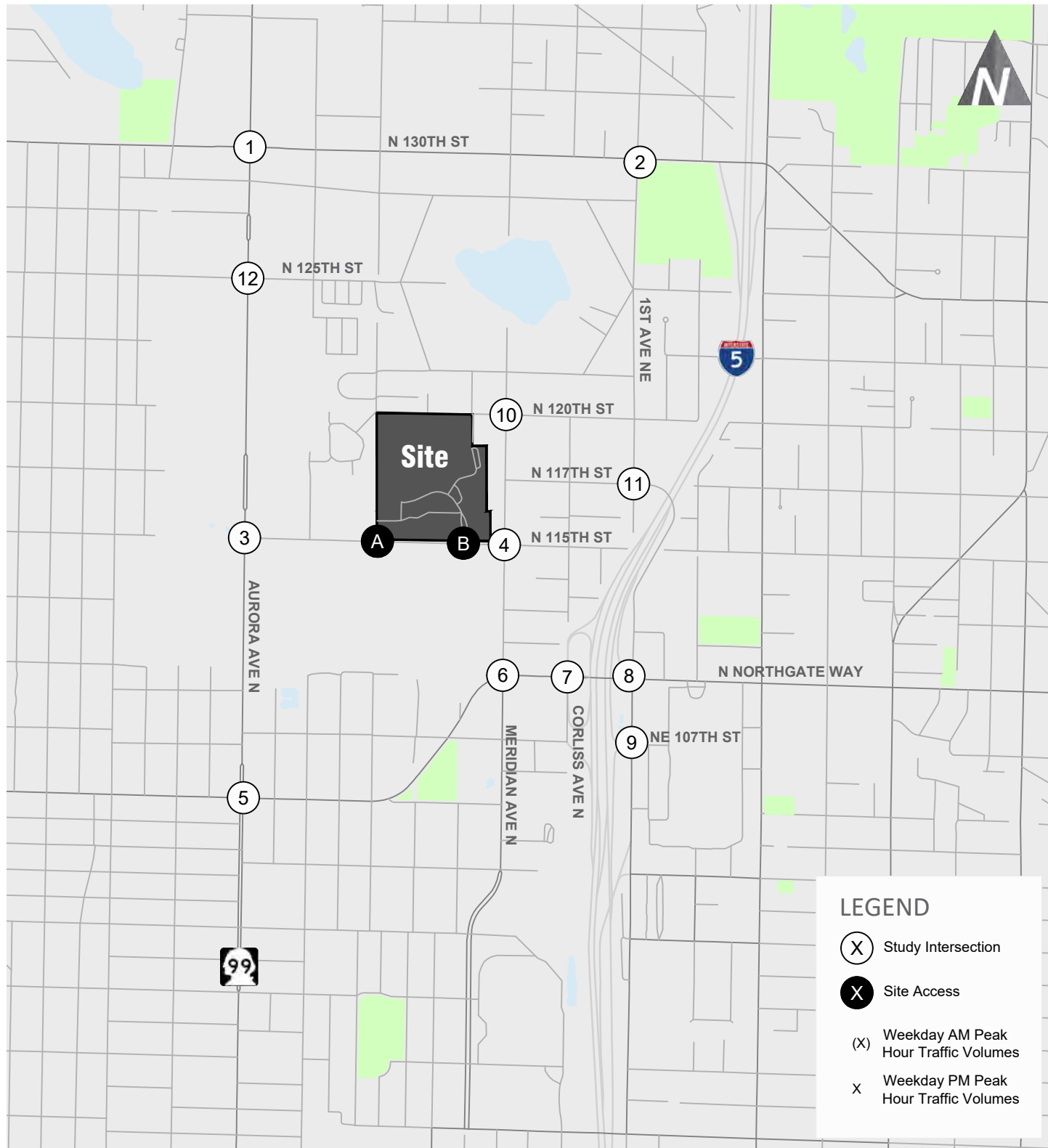

Figure 9. Existing Bike Facilities

Traffic Volumes

Existing traffic volumes at the off-site study intersections were based on traffic counts collected in January 2023 and July 2023 with the existing campus counted in May 2022. The estimated existing weekday AM and PM peak hour traffic volumes are shown on Figure 10. The traffic volumes are rounded to the nearest five vehicles to account for daily fluctuations in traffic. The detailed weekday peak period traffic counts are included in Appendix A.



Existing Weekday Peak Hour Traffic Volumes

UWMC NW TDR

FIGURE

10

Traffic Operations

Weekday peak hour traffic operations for existing conditions are evaluated at the study intersections. The operational characteristics of an intersection are determined by calculating the intersection level of service (LOS). At signalized and all-way stop controlled intersections, LOS is measured in average control delay per vehicle and is typically reported using the intersection delay. At side-street stop-controlled intersections, LOS is measured in average delay per vehicle and is reported for the worst operating movement of the intersection. Traffic operations and average vehicle delay for an intersection can be described qualitatively with a range of levels of service (LOS A through LOS F), with LOS A indicating free-flowing traffic and LOS F indicating extreme congestion and long vehicle delays. Appendix D contains a detailed explanation of LOS criteria and definitions.

Signal timing and phasing information is obtained from the Seattle Department of Transportation (SDOT). Weekday AM and PM peak hour traffic operations are evaluated based on the procedures identified in the *Highway Capacity Manual, 6th Edition* (HCM 6) as available and HCM 2000 for the signalized intersections that are unable to be evaluated in 6th edition due to the limitations of the methodology. *Synchro 11* was used for the analysis which is a software program that uses HCM methodology to evaluate intersection LOS and average vehicle delay. The worst movement is reported for the unsignalized intersections.

The City of Seattle’s Comprehensive Plan does not define a LOS standard for individual intersections; however, the City generally recognizes LOS E and F as poor operations for signalized locations and LOS F for unsignalized locations. Results for the existing operations analyses are summarized in Table 7. Detailed LOS worksheets for each intersection analysis are included in Appendix E. As noted in the Analysis Methods section, the City generally recognizes LOS E and F as poor operations for signalized locations and LOS F for unsignalized locations.

Table 7. Existing Peak Hour Level of Service Summary

Intersection	Traffic Control	Weekday AM Peak Hour			Weekday PM Peak Hour		
		LOS ¹	Delay ²	WM ³	LOS	Delay	WM or v/c
1. Aurora Ave N/N 130th St	Signal	D	44	-	D	42	-
2. 1st Ave NE/N 130th St	Signal	C	29	-	D	35	-
3. Aurora Ave N/N 115th St	Signal	A	9	-	B	14	-
4. Meridian Ave N/N 115th St	AWSC	B	15	-	C	17	-
5. Aurora Ave N/N Northgate Way	Signal	D	46	-	D	49	-
6. Meridian Ave N/N Northgate Way	Signal	D	44	-	D	48	-
7. Corliss Ave N/N Northgate Way	Signal	C	23	-	C	23	-
8. 1st Ave NE/N Northgate Way	Signal	C	24	-	D	37	-
9. 1st Ave NE/I-5 NB Ramp/NE 107th St	Signal	C	32	-	E	65	-
10. Meridian Ave N/N 120th St	TWSC	B	12	WB	B	12	WB
11. 1st Ave NE/N 117th St	AWSC	A	8	-	B	13	-
12. Aurora Ave N/N 125th St	Signal	C	27	-	D	36	-
A. Existing Western Site Access/N 115th St	TWSC	C	15	SBL	C	16	SBL
B. Existing Eastern Site Access/N 115th St	TWSC	C	18	SBL	C	19	SBL

Note: TWSC = Two-Way Stop Controlled, AWSC = All-Way Stop=Controlled. **Bold** text indicates operating at LOS E or F if signalized or LOS F for stop controlled.

1. Level of Service (A – F) as defined by the Highway Capacity Manual (TRB, 6th Edition).
2. Average delay per vehicle in seconds
3. Worst movement reported for TWSC intersections. WB = westbound, SBL = southbound left-turn.

Table 7 shows the study intersections currently operate acceptably at LOS D or better during the weekday AM and PM peak hours, with the exception of the 1st Avenue NE/I-5 NB Ramp/NE 107th Street intersection. The intersection is shown to currently operate at LOS C during the AM peak hour and LOS E during the weekday PM peak hour.

Traffic Safety

Recent collision records were reviewed within the study area to identify existing traffic safety issues at the study intersections and along the project site frontage. The most recent three-year summary of accident data from the Seattle Department of Transportation (SDOT) is for the period between January 1, 2019 and December 31, 2021. This information is summarized in Table 8.

Table 8. Three-Year Collision Summary – 2019 to 2021

Location	Traffic Control	Number of Collisions			Total	Annual Average	Collisions involving a pedestrian or bicyclist over the previous 3 Years
		2019	2020	2021			
<u>Intersections</u>							
1. Aurora Ave N/N 130th St	Signal	5	6	8	19	6.33	0
2. 1st Ave NE/N 130th St	Signal	2	2	0	4	1.33	0
3. Aurora Ave N/N 115th St	Signal	4	0	5	9	3.00	4
4. Meridian Ave N/N 115th St	AWSC	0	0	1	1	0.33	1
5. Aurora Ave N/N Northgate Way	Signal	8	8	9	25	8.33	3
6. Meridian Ave N/N Northgate Way	Signal	3	9	3	15	5.00	1
7. Corliss Ave N/N Northgate Way	Signal	2	7	3	12	4.00	1
8. 1st Ave NE/N Northgate Way	Signal	2	7	4	13	4.33	1
9. 1st Ave NE/I-5 NB Ramp/NE 107th St	Signal	0	1	0	1	0.33	0
10. Meridian Ave N/N 120th St	TWSC	1	0	0	1	0.33	0
11. 1st Ave NE/N 117th St	AWSC	1	0	0	1	0.33	0
12. Aurora Ave N/N 125th St	Signal	1	7	7	15	5.00	3
A. Existing Western Site Access/N 115th St	TWSC	0	0	0	0	0.00	0
B. Existing Eastern Site Access/N 115th St	TWSC	1	0	1	2	0.67	1
<u>Roadway Segment</u>							
Site Frontage/N 115th Street	-	0	2	4	6	2.00	0
Site Frontage/N 120th Street	-	0	0	0	0	0.00	0

Source: SDOT, 2023.

Note: TWSC = Two-Way Stop Controlled, AWSC = All-Way Stop=Controlled.

SDOT defines High Collision Locations (HCL) as signalized intersections with an average of 10 or more collisions, unsignalized intersections with an average 5 or more collisions, mid-block locations with an average of 10 or more collisions, and locations with 5 or more pedestrian or bicycle collisions in the previous 3 years. Intersections designated as high accident locations are targeted for future safety improvements in an effort to reduce the occurrence of accidents. As shown in Table 8, there are no intersections during the review period that meet the HCL criteria as defined by the City of Seattle .

The study intersections had an annual average of approximately 8 collisions or fewer reported per year. Note that the majority of collisions resulted in property damage throughout the study area and there were was one reported fatality. Additionally, there were 1 to 4 reported collisions involving a pedestrian or bicyclist that occurred at 8 of the study intersections including Meridian Avenue N, Corliss Avenue N and 1st Avenue N along N Northgate Way and at Aurora Avenue N and Meridian Avenue N along N 115th Street as well as the eastern site access. The existing safety concerns along Aurora Avenue N are known and there are planned improvements along the Aurora Avenue North corridor to address safety and mobility issues, which are described in the No Action section.

At the existing campus access points, there was an average of less than 1 collision reported per year which resulted in property damage only. Along the campus frontages, there were no reported collisions to the north along N 120th Street and an average of 2 collisions reported per year to the south along N 115th Street. The collisions along N 115th Street were predominately associated with on-street parking with the majority resulting in property damage only. No fatalities nor collisions involving a pedestrian or bicyclist were reported adjacent to the campus during the review period.

Loading

The UWMC – Northwest campus functions primarily with a single loading dock that contains five loading berths, of which three are actively used. The other two berths accommodate compactors for garbage and recycling. The existing loading dock acts as a centralized location for all hospital deliveries.

Observations were completed in 2023 at the existing loading dock in order to identify the current campus demands and to establish rates to be used in identifying the future needs of the campus. Observations were conducted for a two-day period between the hours of 5:00 a.m. and 9:00 p.m. Quiet hours of the campus result in very limited deliveries outside this time period; however, the dock remains open for deliveries. All parcel deliveries were recorded that utilized the loading dock area. Other vehicle classes that accessed the loading docks were passenger cars, panel vans, larger box-trucks, maintenance vehicles, and/or smaller tractor trailers. All vehicle classes were included in the calculations to estimate a conservative rate inclusive of all vehicles accessing the loading dock. A summary of the existing site attributes and an overview of the observations is included in Table 9.

Table 9. Loading Berth Survey Building Attributes and Observation Periods

Building	Date of Observations	Number of Observation Days	Campus Development Area (gsf)	Number of Berths
UWMC - Northwest	April 2023	2	549,697 sf	3 active loading berths, with 2 separate berths for garbage and recycling

A summary of the average delivery activity during the study period at the existing UWMC-Northwest facility is provided in Table 10. As this information will be used to identify the overall loading dock requirements for the MIMP, an overall demand rate was calculated based on the total occupancy of each loading dock, during the observation periods and the total development area of the campus.

Table 10. Loading Berth Weekday Activity Summary

	Day 1 (4/26/2023)	Day 2 (4/27/2023)	Average
Activity			
Deliveries per Day (all vehicles)	27	31	29
Duration			
Average Duration (min)	18.1	23.8	21.1
Total Delivery Time (min)	489	736	621
Delivery Time (min) per 1,000 sf	0.89	1.34	1.13
Notes: sf = square-feet Source: Transpo Group, April 2023			

As shown in Table 10, the weighted average delivery demand for the existing campus equates to 1.13 minutes per 1,000 square feet.

Impacts of the No Action Alternative

This chapter describes the transportation conditions for the future (2030 and 2040) No Action Alternative. The No Action Alternative is the metric by which the Action Alternatives impacts are measured against to identify the transportation impacts of the proposal.

The No Action Alternative assumes the development to date including the existing 549,697 gsf medical center, the Behavior Health Training Facility (BHTF) which will construct an additional 188,846 gsf, and the additional 26,000 gsf of development assumed as the remaining balance of development under the current MIMP. The No Action total is estimated to be 764,543 gsf. The two (2) existing access points that exist along N 115th Street will be maintained under the No Action Alternative.

Trip Generation

The two No Action developments include the BHTF as well as the remaining balance of development under the current MIMP (an additional 26,000 gsf). The weekday AM and PM peak hour trip generation for each component of the No Action condition is described below.

BHTF - Assumed consistent with the previous traffic analysis completed for that specific development.

Additional Development under the current MIMP – The additional 26,000 gsf of hospital space was estimated based on the existing campus trip generation rates as shown in Table 2.

Table 11 summarizes the trip generation for the No Action Alternative.

Land Use	Size	Weekday Daily Trips	AM Peak Hour Trips			PM Peak Hour Trips		
			In	Out	Total	In	Out	Total
Existing¹	549,697 gsf	7,300	407	199	606	113	403	516
No Action								
Additional Development under the current MIMP ¹	26,000 gsf	1,400	19	10	29	5	19	24
<u>BHTF²</u>	<u>188,846 gsf</u>	350	<u>76</u>	<u>44</u>	<u>120</u>	<u>-6</u>	<u>79</u>	<u>73</u>
<i>Subtotal</i>	<i>214,846 gsf</i>	<i>1,750</i>	<i>95</i>	<i>54</i>	<i>149</i>	<i>-1</i>	<i>98</i>	<i>97</i>
No Action Total	764,543 gsf	9,050	502	253	755	112	501	613

1. Vehicle peak hour trip rates calculated based on the existing campus observed peak hour trips relative to the existing size (549,697 gsf). Daily trip rate estimated based on similar ITE uses.
 2. Behavioral Health Teaching Facility

As shown in the table, under the No Action Alternative the campus is forecast to generate 755 trips occurring during the weekday AM peak hour and 613 trips during the weekday PM peak hour. This represents an increase of 149 trips during the weekday AM peak hour and 97 trips during the weekday PM peak hour.

The total person trip generation for the campus was estimated for the peak hours based on the same methodology as assumed for the affected environment with no changes assumed to the mode splits or AVO. The estimated No Action person trip generation is summarized in Table 12.

Table 12. No Action Person Trip Generation

Trip Generation	Mode Split	Existing			Net New No Action			No Action Total		
		In	Out	Total	In	Out	Total	In	Out	Total
Weekday AM Peak Hour										
Vehicle Trips¹		407	199	606	95	54	149	502	253	755
Person Trips										
Walk and Bike Trips	2.5%	13	6	19	3	2	5	16	8	24
Transit Trips	7%	35	17	53	8	5	13	43	22	66
Other	1.5%	8	4	11	2	0	2	10	4	13
<u>Person Trips by Vehicle¹</u>	<u>89%</u>	<u>451</u>	<u>220</u>	<u>671</u>	<u>105</u>	<u>60</u>	<u>165</u>	556	280	836
Total	100%	507	247	754	118	67	185	625	314	939
Weekday PM Peak Hour										
Vehicle Trips¹		113	403	516	-1	98	97	112	501	613
Person Trips										
Walk and Bike Trips	2.5%	4	13	16	0	3	3	4	16	19
Transit Trips	7%	10	35	45	0	8	8	10	43	53
Other	1.5%	1	8	10	0	1	2	1	9	12
<u>Person Trips by Vehicle¹</u>	<u>89%</u>	<u>125</u>	<u>446</u>	<u>571</u>	<u>-1</u>	<u>109</u>	<u>107</u>	124	555	678
Total	100%	140	502	642	-1	121	120	139	623	762

1. The 89 percent person trips by vehicle includes approximately 75 percent SOV and 14 percent associated with carpool and vanpool trips, resulting in a AVO of 1.1. The AVO of 1.1 was multiplied by the vehicles trips to determine the number of person trips by vehicle. The person trip distribution per the CTR was then applied to determine the total person trips.

As shown in Table 12, with the No Action, there are estimated to be a total of 66 and 53 transit trips in the AM and PM peak hours, respectively and 24 and 19 non-motorized trips (walk, bike, other) in the AM and PM peak hours, respectively.

Street System

The No Action Alternative assumes no change in UWMC-Northwest vehicle access and circulation. The existing access including two primary access points along N 115th Street will be maintained with the No Action Alternative. A review of local and regional capital improvement programs and long-range transportation plans was conducted to identify planned funded and unfunded transportation projects that would impact the off-site study area within the study period. The City of Seattle 2023 – 2028 *Proposed Capital Improvement Program* (CIP) and Comprehensive Plan was reviewed and two projects were identified: (1) Aurora Avenue North Safety Improvements project and (2) N 130th Street Vision Zero Safety Corridor. Both projects are described below.

Aurora Avenue North Safety Improvements project - This project will improve safety and mobility along Aurora Avenue N. The project includes design and construction of new sidewalks, transit improvements, medians/access management, lighting, signalized crossings, and potential roadway channelization changes. This project is fully funded and anticipated to be completed by 2037. The specific locations along the corridor have not yet been identified.

N 130th Street Vision Zero Safety Corridor - The cross section at N 130th Street currently has four driving lanes with a sidewalk on each side of the road and will be modified into two through-lanes between Stone Avenue N and 1st Avenue NE with bike lanes and a center two-way left turn lane. Speed limits will also be reduced to 25 mph along the corridor as well as restricting right-turns on red (RTOR). Future extension of the channelization modifications are also a potential which could extend between Linden Avenue N and 5th Avenue NE. The channelization modifications, bike lanes, and speed limit reductions between Stone Avenue N and 1st Avenue NE along N 130th Street are planned to be completed in 2023 and are funded as part of the Vision Zero program. This project results in assumed channelization modifications to the west leg of the 1st Avenue NE/N 130th Street intersection included in the No Action analyses.

Seattle Public Utilities (SPU) is also planning improvements along N 117th Street and N 120th Street between Meridian and 1st Avenues. These improvements include reconstruction of the ROW to include improved natural drainage features, defined parallel parking on one side of the street, with a single lane for two-way traffic. This project is intended to improve drainage and water quality for Thornton Creek, improve pedestrian facilities and provide traffic calming features.

Improvements to the south side of N 120th Street, along the campus frontage are also being completed as part of the BHTF project. These improvements include construction of curb, gutter, sidewalk, and a landscaping strip.

Non-Motorized Transportation

Based on a review of the City's CIP⁴ and the 2021-2024 Seattle Bicycle Master Plan four planned improvements have been identified with changes to existing non-motorized system in the vicinity of the campus. These include:

- Safety improvements along Aurora Avenue will construct new non-motorized facilities including new sidewalks and signalized crossings.
- Bike lanes are proposed to be added along both sides of N 130th Street between Stone Avenue N and 1st Avenue NE as part of the Vision Zero Safety Corridor project by 2023.
- The Ashworth Avenue N Neighborhood Greenway is planned to be completed by 2024 and would extend from N 135th Street to N 120th Street connecting to Northgate Elementary School and Ingraham High School. Within the study area at the Meridian Avenue N/N 120th Street intersection, the project would install curb ramps at 4 corners, full concrete curbs at NE and NW corners to connect to the existing bus pads, add a marked crosswalk on the north leg, and paint two curb bulbs at the SE and SW corners.
- Painted bike lanes are proposed to be added along Meridian Avenue between N 117th Street and N 120th Street as noted on SDOT's Planned Bike Facilities map.
- The improvements planned by SPU along N 117th Street and N 120th Street will improve pedestrian connections for those sections. These improvements are anticipated to be completed by 2023.

Non-motorized trips associated with the No Action condition are anticipated to be limited with 5 or fewer non-motorized trips estimates for the AM and PM peak hours for a total No Action non-motorized trips associated with the campus to be 24 and 19 trips during the weekday AM and PM peak hours, respectively.

Transit Service

Transit service changes in the vicinity of the UWMC-Northwest predominantly include the expansion of Sound Transit's Link Light Rail Network. Future planned transit improvements include the Sound Transit Link Light Rail Lynnwood Extension. Sound Transit's Link Light Rail Lynnwood Extension is extending light rail from the Northgate station to Lynnwood and constructing four additional stations: Shoreline South/148th Station, Shoreline North/185th Station, Mountlake Terrace Station, Lynnwood City Center Station. The Lynnwood Extension is due to open by end of 2024. Following the opening of the Lynnwood Extension, the NE 130th St Infill Station is planned to be added for operation along the Lynnwood Extension for service by 2026.

With the planned Sound Transit Link Light Rail Lynnwood Extension, King County Metro has identified preliminary service concepts that would adjust routes to account for the added light rail stations. In the vicinity of UWMC-Northwest, this includes current route and service adjustments to serve the Shoreline South/148th Station (no plans have yet identified service alterations to accommodate the NE 130th St

⁴ 2023-2028 Proposed Capital Improvement Program

Infill Station). Route adjustments would include revising the service areas of 345 and replacing route 346 with a new route, route 365. Both routes would provide service along Meridian Avenue N, east of UWMC-Northwest with Route 345 continuing to have a stop on-campus and both routes now providing service to the Shoreline South/148th Station. Both routes would be local routes, similar to today’s service.

With these proposed service revisions, no service changes to the transit frequency or capacities were assumed for the routes being evaluated; however, Route 346 is shown to be replaced with Route 365.

Future No Action ridership was estimated for the future 2040 horizon year by applying an annual 2.0 percent growth rate (consistent with the overall forecast growth in traffic volume at the study intersections when including both the annual background growth rate and pipeline traffic as discussed in greater detail in a subsequent section) to the existing ridership and adding transit trips for the campus specific to the No Action condition. The peak hour transit trips associated with the No Action condition as summarized in Table 12, are anticipated to be 13 and 8 during the weekday AM and PM peak hours, respectively. Note that the transit trip generation estimates are for the peak hour, whereas the transit analysis is for the peak transit periods (4-hour periods, 5-9 am and 3-7 pm). The peak hour transit trips were converted to the 4-hour transit period by multiplying the trips by 4, which conservatively assumes that peak hour transit trips for the campus occur continuously throughout the 4-hour transit period.

Based on the ridership forecasts, the resulting No Action capacity analysis is summarized in Table 13 for the 2040 future condition during the AM and PM peak periods relative to the existing utilization. The detailed transit capacity analysis is included in Appendix F. As shown in the table, the transit vehicle utilization for the 4 routes serving the campus is approximately 43 percent or less under the No Action condition, with estimated increases in utilization of 12 percent or less relative to existing conditions. This analysis indicates that there would continue to be available capacity to accommodate additional riders during the weekday peak periods under the No Action Alternative.

Table 13. No Action (2040) Transit Capacity Analysis

Route # / Nearest Stop Location	Direction of Travel	AM Peak Period Utilization ¹			PM Peak Period Utilization		
		Existing	No Action	Change	Existing	No Action	Change
345 On Campus, north of eastern access point	S	15%	27%	+ 12%	19%	28%	+ 9%
	N	18%	29%	+ 11%	25%	37%	+ 12%
365 ³ At the Meridian Ave N/ N 115th St Intersection	S	21%	30%	+ 9%	25%	35%	+ 10%
	N	23%	34%	+ 11%	31%	43%	+ 12%
40 At the SR 99/N 115th St Intersection	S	8%	11%	+ 3%	15%	22%	+ 7%
	N	13%	18%	+ 5%	12%	17%	+ 5%
E Line At the SR 99/N 115th St Intersection	N	25%	36%	+ 11%	26%	36%	+ 10%
	S	22%	31%	+ 9%	27%	38%	+ 11%

1. Capacity for each route/stop assumed for the utilization calculation unchanged for No Action relative to existing conditions. Based on bus frequencies, ridership, and typical capacity data provided by King County Metro for Fall 2022. Existing Route 346 to be replaced with new Route 365. Both are local routes such that capacity and existing utilization were assumed to be consistent.

Traffic Volumes

Future (2030 and 2040) forecast traffic volumes for the No Action conditions are comprised of the existing traffic volumes, background traffic growth, and traffic generated from the planned “pipeline” developments. An annual growth rate of 1.0 percent was applied to the existing traffic counts as coordinated with City staff during scoping which is consistent with the growth rate assumed for previously approved for projects throughout Seattle and tends to be conservative with the additional inclusion of growth from pipeline projects. In addition to the background growth rate, which accounts for the general growth in the area, traffic from specific pipeline development projects in the vicinity were added to the forecasts. Pipeline projects included in the analysis were based on information from the SDCI website and confirmed through coordination with City staff. A total of 21 pipeline projects are included. The pipeline projects are listed in Appendix C. The trips associated with the BHTF are included as well as identified above and consistent with the traffic analysis completed for that project. The trips associated

with the remaining MIMP development size (26,000 gsf) were distributed and assigned to the network based on existing vehicle travel patterns as well as review of where employees are working for the existing campus. The distribution patterns are illustrated in Figure 11.

The resulting No Action weekday peak hour traffic volumes are shown for the future 2030 and 2040 conditions in Figure 12 and Figure 13, respectively.

Traffic Operations

The future 2030 and 2040 No Action operations analysis was conducted using the consistent methodology as described for the existing conditions. Adjustments of analysis parameters between the existing and No Action (2030) conditions included optimization⁵ of signal timing to reflect the continued growth in traffic volumes as well as review any applicable adjustments of peak hour factors (PHF) at the off-site study intersections to reflect the forecast traffic volumes. The PHF adjustment in the interim condition was made consistent with National Cooperative Highway Research Program (NCHRP) Report 599: Default Values for Highway Capacity and Level of Service Analyses.⁶

Additional adjustments for the No Action (2040) conditions included additional optimization of signal timings (similar to 2030 conditions) as well as further refinement of the PHF at the off-site study intersections. The 2040 PHF adjustment was made consistent with *WSDOT Synchro & Simtraffic Protocol – Aug 2018* which identifies assuming a PHF of 1.0 for future analysis conditions, with future analysis typically aligning with a design year condition which is generally an approximately 20-year forecast, consistent with the future 2040 analysis.⁷

⁵ Optimization included adjusting the splits and offsets. The existing cycle lengths were maintained for the coordination along the corridor.

⁶ NCHRP's Report 599 Table 19 provides guidance on the applicable PHF relative to the total entering vehicles of an intersection.

⁷ WSDOT's criteria identifies adjustment for the PHF for design year conditions.

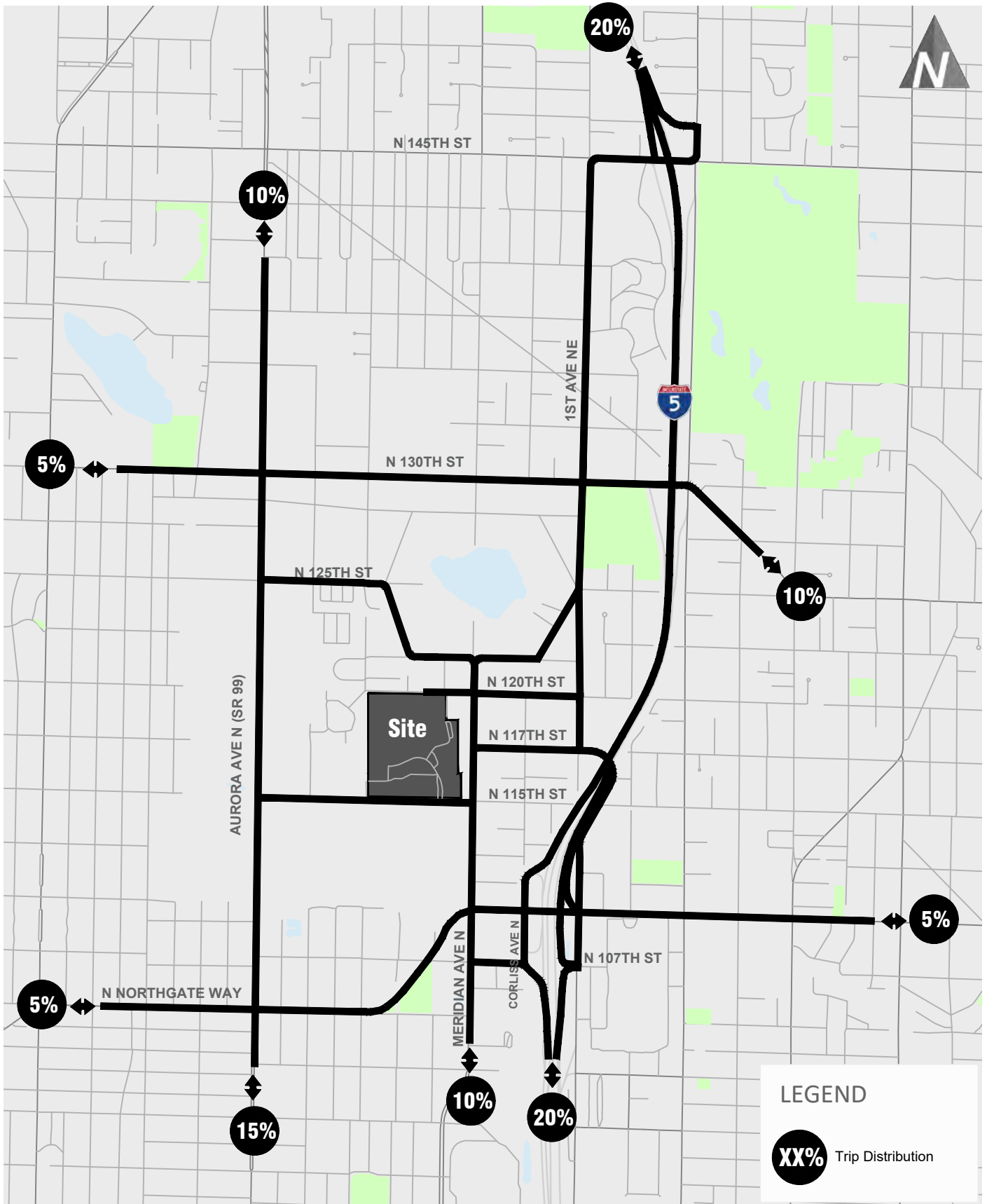

Project Trip Distribution

UWMC NW TDR

FIGURE

11

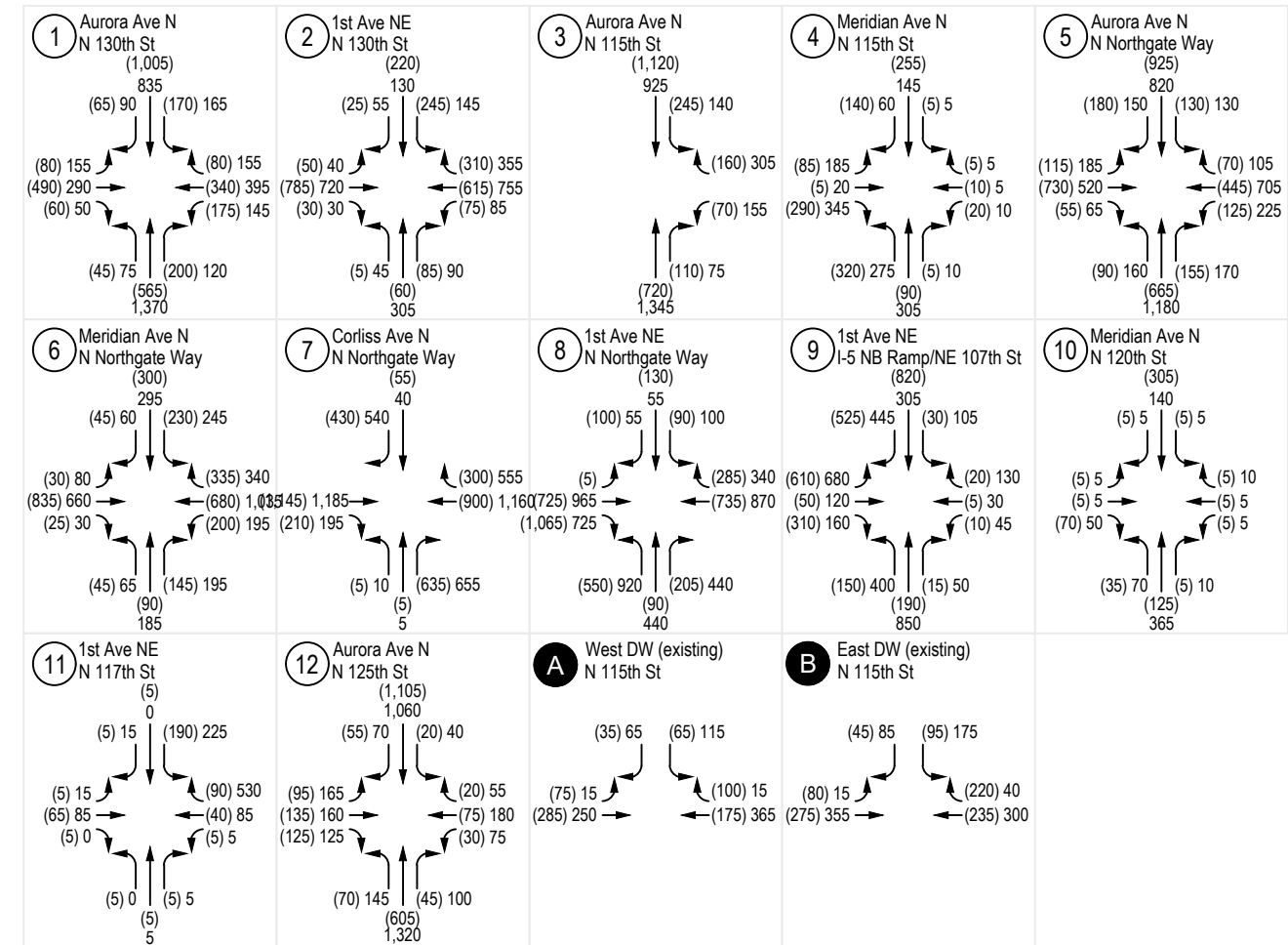
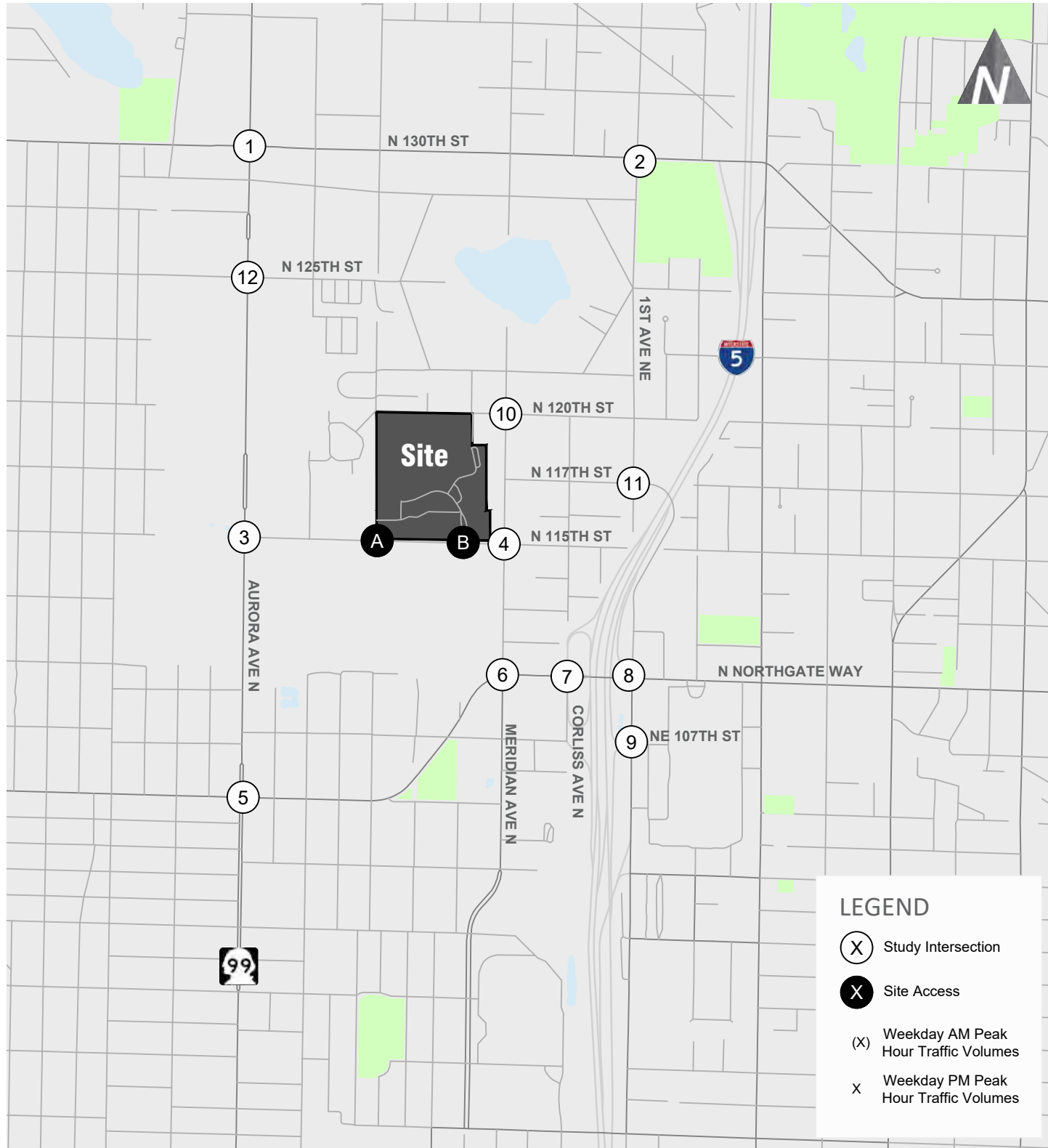

No Action Alternative (2030) Weekday Peak Hour Traffic Volumes

UWMC NW TDR

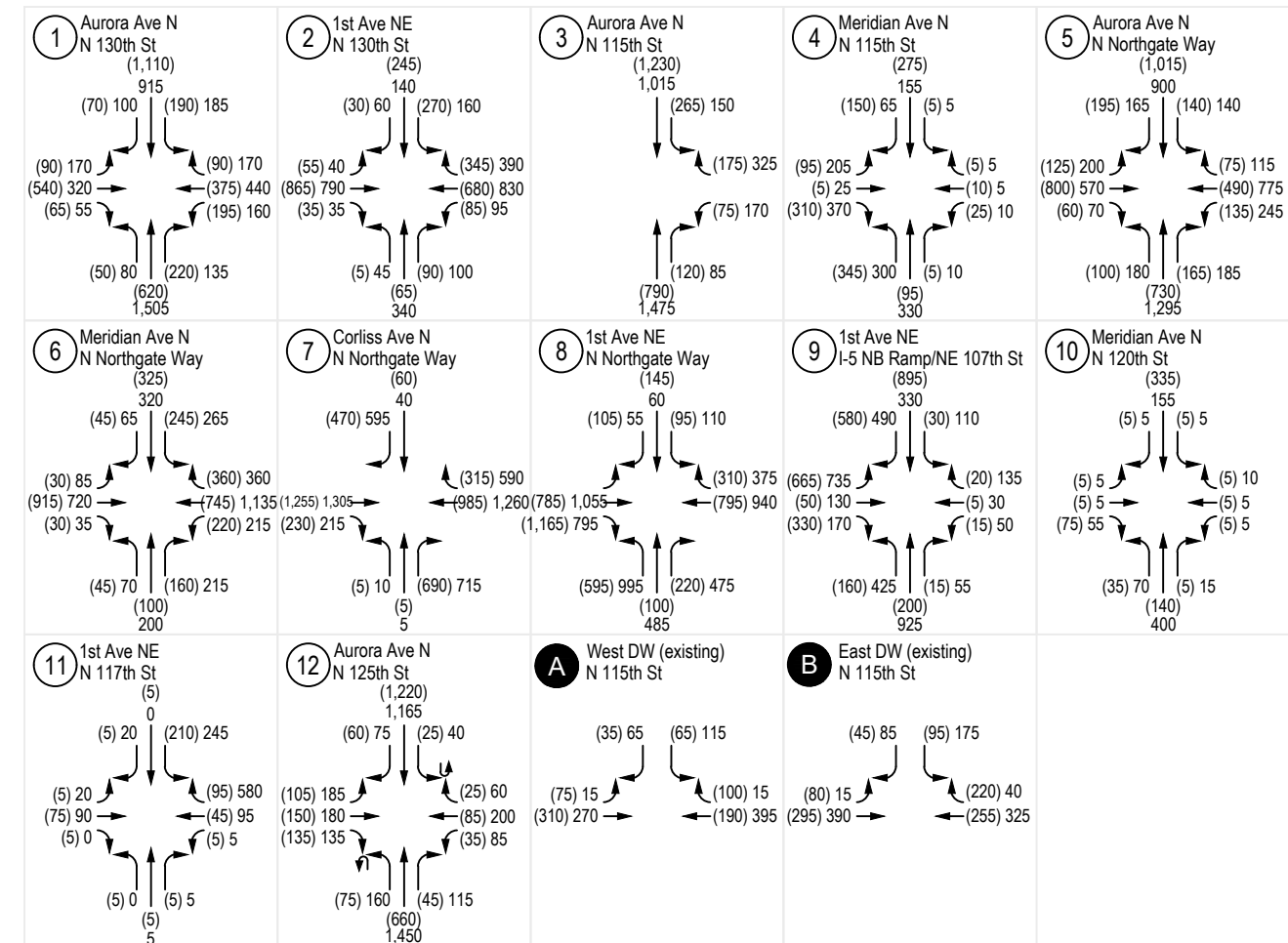
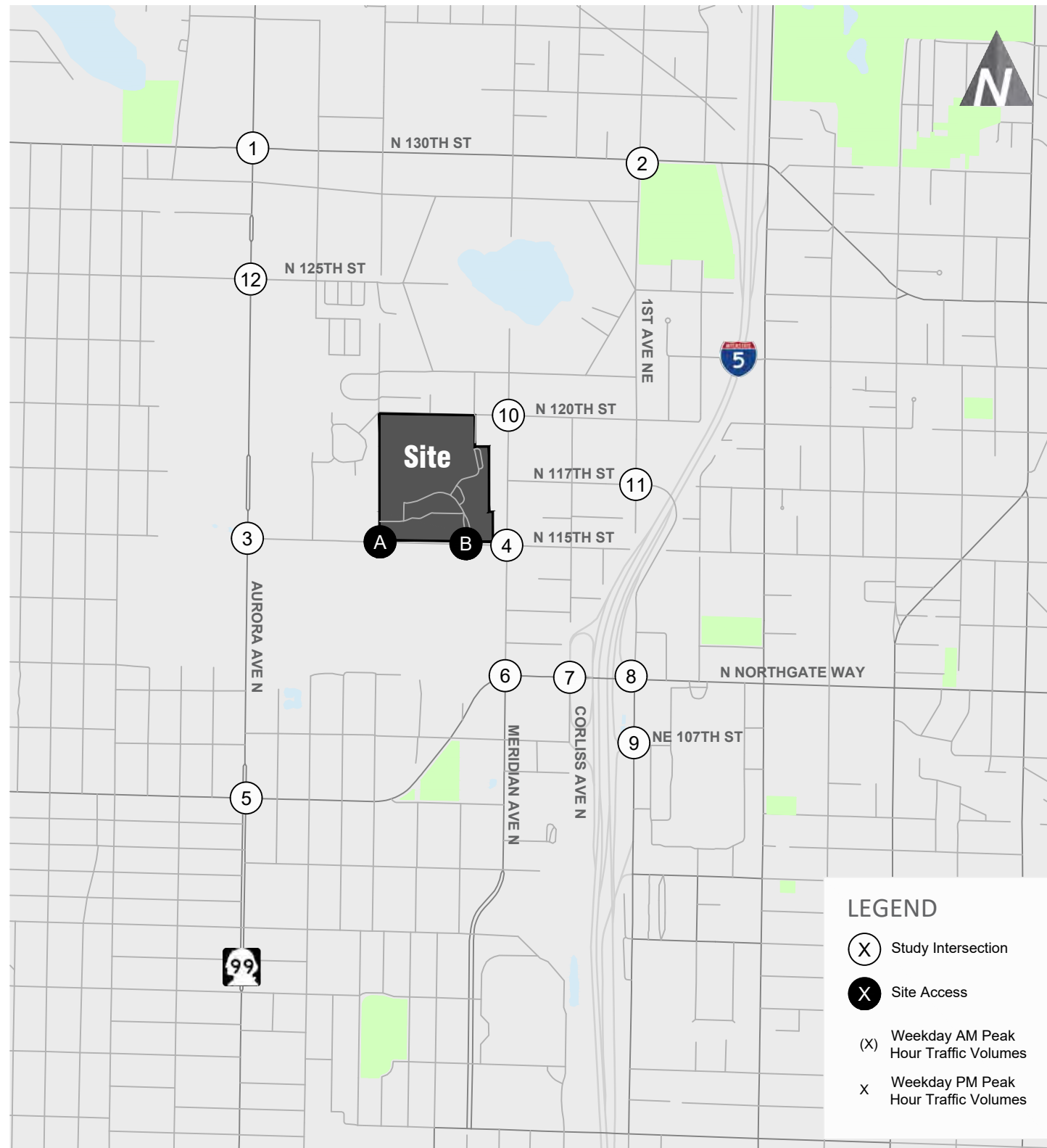

No Action Alternative (2040) Weekday Peak Hour Traffic Volumes

UWMC NW TDR

FIGURE

13



The future 2030 and 2040 No Action weekday peak hour intersection operations are shown in Table 14.

Table 14. Existing and No Action (2030 and 2040) Weekday Peak Hour LOS Summary

Intersection	Traffic Control	Existing			No Action (2030)			No Action (2040)		
		LOS ¹	Delay ²	WM ³	LOS	Delay	WM	LOS	Delay	WM
AM Peak Hour										
1. Aurora Ave N/N 130th St	Signal	D	44	-	D	47	-	D	47	-
2. 1st Ave NE/N 130th St	Signal	C	29	-	D	37	-	D	40	-
3. Aurora Ave N/N 115th St	Signal	A	9	-	B	12	-	B	13	-
4. Meridian Ave N/N 115th St	AWSC	B	15	-	D	26	-	C	24	-
5. Aurora Ave N/N Northgate Way	Signal	D	46	-	D	51	-	D	44	-
6. Meridian Ave N/N Northgate Way	Signal	D	44	-	D	43	-	D	42	-
7. Corliss Ave N/N Northgate Way	Signal	C	23	-	B	10	-	B	13	-
8. 1st Ave NE/N Northgate Way	Signal	C	24	-	C	29	-	C	30	-
9. 1st Ave NE/I-5 NB Ramp/NE 107th St	Signal	C	32	-	E	58	-	E	67	-
10. Meridian Ave N/N 120th St	TWSC	B	12	WB	B	14	WB	B	13	WB
11. 1st Ave NE/N 117th St	AWSC	A	8	-	A	9	-	A	9	-
12. Aurora Ave N/N 125th St	Signal	C	27	-	C	29	-	C	31	-
A. Western Site Access/N 115th St	TWSC	C	15	SBL	C	20	SB	C	17	SBL
B. Eastern Site Access/N 115th St	TWSC	C	18	SBL	D	30	SB	C	23	SBL
PM Peak Hour										
1. Aurora Ave N/N 130th St	Signal	D	42	-	D	44	-	D	49	-
2. 1st Ave NE/N 130th St	Signal	D	35	-	D	46	-	D	53	-
3. Aurora Ave N/N 115th St	Signal	B	14	-	B	18	-	B	18	-
4. Meridian Ave N/N 115th St	AWSC	C	17	-	E	39	-	E	37	-
5. Aurora Ave N/N Northgate Way	Signal	D	49	-	E	56	-	E	60	-
6. Meridian Ave N/N Northgate Way	Signal	D	48	-	C	33	-	D	42	-
7. Corliss Ave N/N Northgate Way	Signal	C	23	-	B	13	-	B	14	-
8. 1st Ave NE/N Northgate Way	Signal	D	37	-	F	97	-	F	103	-
9. 1st Ave NE/I-5 NB Ramp/NE 107th St	Signal	E	65	-	E	57	-	E	62	-
10. Meridian Ave N/N 120th St	TWSC	B	12	WB	B	15	WB	B	14	WB
11. 1st Ave NE/N 117th St	AWSC	B	13	-	C	18	-	C	21	-
12. Aurora Ave N/N 125th St	Signal	D	36	-	D	40	-	D	47	-
A. Western Site Access/N 115th St	TWSC	C	16	SBL	C	21	SB	C	19	SBL
B. Eastern Site Access/N 115th St	TWSC	C	19	SBL	D	30	SB	D	26	SBL

Note: TWSC = Two-Way Stop Controlled, AWSC = All-Way Stop=Controlled. **Bold** text indicates operating at LOS E or F if signalized or LOS F for stop controlled.

1. Level of Service (A – F) as defined by the Highway Capacity Manual (TRB, 6th Edition).
2. Average delay per vehicle in seconds
3. Worst movement reported for TWSC intersections. WB = westbound, SBL = southbound left turn.

As shown in Table 14, with the addition of background traffic growth, pipeline development and the No Action development, 3 of the off-site study intersections are forecast to operate at LOS E or F under the future 2030 and 2040 No Action conditions during either the AM and/or PM peak hours. Additional discussion for the 3 intersections operating at LOS E or F is provided below.

Aurora Avenue N/N Northgate Way – This signalized intersection is forecast to operate at LOS D during the AM peak hour and LOS E in the PM peak hour under both 2030 and 2040 conditions.

1st Avenue NE/N Northgate Way – This signalized intersection is forecast to operate at LOS C during the AM peak hour and LOS F in the PM peak hour under both 2030 and 2040 conditions.

1st Avenue NE/I-5 NB Ramp/NE 107th Street - This signalized intersection is forecast to operate at LOS E during both the weekday AM and PM peak hours under both 2030 and 2040 conditions.

The remaining off-site study intersections and access points are forecast to continue to operate acceptably at LOS D or better. Note that the all-way stop controlled Meridian Avenue N/N 115th Street intersection is forecast to operate at LOS E under future weekday PM peak hour No Action conditions; however, as this is a stop-controlled intersection, it was not identified. Also, note that minor reductions in delay comparing 2040 to 2030 conditions at some off-site study intersections is associated with the change in the PHF to 1.0 as described above, which reflects operations with an even distribution of vehicles throughout the hour consistent with travel patterns as congestion increases.

Traffic Safety

As traffic volumes increase, traffic safety issues could increase proportionally. However, there are no significant safety concerns identified within the study area under existing conditions.

Loading

The No Action condition reflects the construction of the BHTF and infrastructure associated with that construction. Based on current SMC criteria, the BHTF project was required to construct 7 loading berths. 5 of these are expected to be active as two are being used for garbage and recycling compactors. With these additional loading berths, the campus includes a total of 8 active loading berths. Projected demand and utilization of the existing berths is outlined in Table 15. The overall capacity of the loading berths is determined based on the number of berths as well as the period of time that the loading dock is “open”. As this is a medical institution there are core delivery hours, with evening restrictions for quiet hours. Based on the observations, the majority of the activity was observed between 7:00 a.m. and 5:00 p.m. for a total of 10 hours. This was applied for the campus, resulting in a capacity of 600 minutes (10 hours * 60 minutes) per loading berth. This represents a conservative estimate as technically, the loading dock is open 24 hours a day, seven days a week.

Table 15. UWMC – Northwest Loading Berth Utilization Study (MIMP)

Scenario	Size	Demand (minutes) ¹	Number of Loading Berths	Utilization
Existing	549,697 sf	621	3	35%
No Action	764,543 sf	866	8	18%

1. Demand expressed in minutes as identified above.

Based on the 764,543 sf of total development, and considering the existing service rates, there is forecast to be approximately 866 delivery-minutes or 41 deliveries per day in the future.

Assuming the loading berths operate for 10 hours per day similar to the existing data, the total loading berths operational capacity under this scenario is 4,800 minutes (8 berths * 600 minutes per berth). Based on the 866 delivery-minutes, the percent utilization of the loading berths is 18 percent under this scenario. This number shows that the 8 loading berths expected with the completion of the BHTF project are more than adequate to accommodate the projected delivery demands under the No Action condition.

Impacts of Action Alternative 1

This section describes the impacts of the future 2030 and 2040 Action Alternative 1. The impacts of Action Alternative 1 are identified through a comparison to the respective future 2030 and 2040 No Action Alternative.

With Action Alternative 1, the campus development would increase to up to 1,600,000 gsf, reflecting an increase of 835,457 gsf with Alternative 1. For purposes of the traffic analysis, a total of 800,000 gsf was assumed to be developed by 2030, with the remaining balance completed by 2040. The campus parking supply for Alternative 1 will be provided per the MIMP development standards. Two options for an additional campus access point were evaluated under the MIMP. Access options evaluated for Alternative 1 include maintaining the 2 existing access points as well as a third access via either N 115th Street or N 120th Street.

A comparison of the 2030 and 2040 Action Alternative 1 to the respective No Action Alternative is provided in the sections below.

Trip Generation

The trip generation estimates for the additional Alternative 1 development was based on the existing campus trip generation rates but refined to reflect current medical industry standards. Since the existing hospital was constructed, the medical industry has evolved resulting in increased space allocated to each patient. Factors that result in additional area per patient include, eliminating double occupancy rooms, increased medical equipment in each room, and this is a teaching hospital/campus, additional teaching areas will be provided adding to the overall sf per patient calculations. In order to “right-size” the existing hospital space, the hospital area would be expanded by 215,000 gsf provide without additional patients/staff capacity. An adjusted trip generation rate was then calculated by dividing the observed trips by the existing square footage plus the 215,000 gsf to account for right sizing. The existing and right-size adjusted trip generation rate is summarized in Table 16 which reduces the trip rates to 0.79 and 0.67 trips per 1,000 gsf for the AM and PM peak hours, respectively.

Table 16. Right Sized Vehicular Trip Generation Rate

Trip Generation Rate ¹	Effective Area	Weekday Daily	Weekday AM Peak Hour			Weekday PM Peak Hour		
			In	Out	Total	In	Out	Total
<i>Average Existing Trips</i>		7,300	407	199	606	113	403	516
Existing	549,697 gsf	13.2			1.10			0.94
Right Size Adjusted	764,697 ² gsf	9.5			0.79			0.67

Note: gsf = gross square feet

1. Trip Generation Rate = trips per 1,000 gsf.

2. Existing size (549,697 gsf) + right size adjustment (+215,000 gsf).

This adjusted trip generation rate was applied to the expansion area identified under Alternative 1. Note that the current campus is made up of both hospital and medical office uses, which typically have different trip generation rates (with a hospital having a lower trip generation rate than a medical office). The existing allocation of hospital and medical office is approximately 65 percent and 35 percent, respectively. The allocation of hospital and medical office uses for the future development are estimated to be approximately 80 percent and 20 percent, respectively, shifting to have a higher amount of hospital with the future development. With the assumed use of the overall campus size (not allocating per use), the trip generation rates would continue to reflect the current split of hospital and medical office. This provides a conservative estimate of the Action Alternatives trip generation given the anticipated increase in allocation of hospital space which has a lower individual trip generation rate relative to medical office.

The Alternative 1 vehicular trip generation estimates for the weekday AM and PM peak hours for both the future 2030 and 2040 development is summarized in Table 17.

Table 17. Alternative 1 Weekday Vehicle Trip Generation

Land Use	Size	Weekday Daily	AM Peak-Hour Trips			PM Peak-Hour Trips		
			In	Out	Total	In	Out	Total
Existing	549,697 gsf	7,300	407	199	606	113	403	516
No Action Total	764,543 gsf	9,050	502	253	755	112	501	613
Alternative 1 MIMP Addition								
2030 - Interim Buildout	+800,000 gsf	7,600	425	208	633	118	421	539
Alternative 1 Subtotal	1,564,543 gsf	7,950	445	217	662	123	440	563
2040 - Full buildout of the MIMP	+835,457 gsf	16,650	927	461	1,388	230	922	1,152
Alternative 1 Total	1,600,000 gsf	17,000	947	470	1,417	235	941	1,176

1. Vehicle trip rates calculated based on the observed peak hour trips relative to the "right sized" size (764,697gsf).

As shown in the table, the campus with the 2030 interim buildout is forecast to generate 1,388 trips occurring during the weekday AM peak hour and 1,152 trips during the weekday PM peak hour. This represents an increase of 633 trips during the weekday AM peak hour and 539 trips during the weekday PM peak hour relative to the No Action condition.

With the full buildout of the MIMP by 2040, a campus total of up to 1,600,000 gsf, the campus is forecast to generate 1,417 trips occurring during the weekday AM peak hour and 1,176 trips during the weekday PM peak hour. This represents an increase of 662 trips during the weekday AM peak hour and 563 trips during the weekday PM peak hour relative to the No Action condition.

The total person trip generation for the campus assuming the Full buildout of the MIMP was estimated for the peak hours based on the same methodology as assumed for the affected environment and No Action with no changes assumed to the mode splits or AVO (see Table 18).

Table 18. Total Alternative 1 Person Trip Generation

Trip Generation	Mode Split	No Action			2040 - Full buildout of the MIMP			Total Alternative 1 (1,600,000 gsf)		
		In	Out	Total	In	Out	Total	In	Out	Total
Weekday AM Peak Hour										
Vehicle Trips¹		502	253	755	445	217	662	947	470	1,417
Person Trips										
Walk or Bike Trips	2.5%	16	8	24	14	7	21	30	15	45
Transit Trips	7%	43	22	66	39	19	58	82	41	124
Other	1.5%	10	4	13	8	4	12	18	8	25
Person Trips by Vehicle ¹	<u>89%</u>	556	280	836	<u>493</u>	<u>240</u>	<u>734</u>	1,049	520	1,570
Total	100%	625	314	939	554	270	824	1,179	584	1,763
Weekday PM Peak Hour										
Vehicle Trips¹		112	501	613	123	440	563	235	941	1,176
Person Trips										
Walk or Bike Trips	2.5%	4	16	19	4	14	18	8	30	37
Transit Trips	7%	10	43	53	11	38	49	21	81	102
Other	1.5%	1	9	12	2	8	11	3	17	23
Person Trips by Vehicle ¹	<u>89%</u>	124	555	678	<u>136</u>	<u>488</u>	<u>624</u>	260	1,043	1,302
Total	100%	139	623	762	153	548	701	292	1,171	1,463

1. The 89 percent person trips by vehicle includes approximately 75 percent SOV and 14 percent associated with carpool and vanpool trips, resulting in a AVO of 1.1. The AVO of 1.1 was multiplied by the vehicles trips to determine the number of person trips by vehicle. The person trip distribution per the CTR was then applied to determine the total person trips.

As shown in Table 18, with Alternative 1, there are estimated to be a total of 124 and 102 transit trips in the AM and PM peak hours, respectively and 45 and 37 non-motorized trips (walk, bike, other) in the AM and PM peak hours, respectively.

Street System

No changes are proposed to the off-site street network as a result of Action Alternative 1 relative to the No Action condition. The two existing access points along N 115th Street will be maintained with Alternative 1. A third access is proposed to serve the campus which would be provided via either N 115th Street or N 120th Street. Additional review of the access points is provided in the Site Access Review section below.

Non-Motorized Transportation

No frontage improvements are expected to be completed with the proposed MIMP as frontage improvements have all been completed. As noted in the No Action section, improvements to N 120th Street, Burke Avenue N, and N 115th Street are being completed as part of the BHTF project.

Non-motorized trips associated with the Alternative 1 2040 Full buildout of the MIMP are anticipated to be limited with approximately 20 non-motorized trips estimated for the AM and PM peak hours. This equates to a total Alternative 1 non-motorized trips associated with the campus to be 45 and 37 trips during the weekday AM and PM peak hours, respectively, under the future (2040) condition.

Transit

No changes are proposed to transit service as a result of Action Alternative 1, such that transit capacities are consistent with the No Action condition as described above. The total future (2040) Alternative 1 transit trips were estimated by adding the forecast Alternative 1 additional transit trips to the future (2040) No Action transit trips. The peak hour transit trips associated with Alternative 1 2040 Full Buildout of the MIMP condition as summarized in Table 18, are anticipated to be 58 and 49 during the weekday AM and PM peak hours, respectively. As noted above, the peak hour transit trips were converted to the 4-hour transit period by multiplying the trips by 4, which conservatively assumes that peak hour transit trips for the campus occur continuously throughout the 4-hour transit period.

Based on the transit forecasts, the resulting Alternative 1 vehicle capacity analysis is summarized in Table 19 for the 2040 future condition during the AM and PM peak periods relative to the No Action utilization. The detailed transit capacity analysis is included in Appendix F.

Table 19. Alternative 1 Transit Capacity Analysis

Route # / Nearest Stop Location	Direction of Travel	AM Peak Period Utilization ¹			PM Peak Period Utilization		
		No Action	Alternative 1	Change	No Action	Alternative 1	Change
345 On Campus, north of eastern access point	S	27%	50%	23%	28%	42%	14%
	N	29%	48%	19%	37%	49%	12%
346 At the Meridian Ave N/ N 115th St Intersection	S	30%	33%	3%	35%	37%	2%
	N	34%	37%	3%	43%	45%	2%
40 At the SR 99/N 115th St Intersection	S	11%	12%	1%	22%	22%	<1%
	N	18%	19%	1%	17%	18%	1%
E Line At the SR 99/N 115th St Intersection	N	36%	37%	1%	36%	37%	1%
	S	31%	32%	1%	38%	38%	<1%

1. Capacity for each route/stop assumed for the utilization calculation unchanged for Alternative 1 relative to No Action conditions for future (2040) conditions.

As shown in the table, the transit vehicle utilization for the 4 routes serving the campus is approximately 50 percent or lower under the Alternative 1 condition, with estimated increases in utilization of 23 percent or less relative to No Action conditions. It was assumed that a greater percentage of transit trips would be via Route 345 compared to other routes due to its proximity to campus (a stop located on-campus) and connectivity to the Link Light Rail Station. This assumption is reflected in the table, with a forecast 12 to 23 percent increase on Route 345 compared with the other routes of 3 percent or less.

There would continue to be available capacity to accommodate additional riders during the weekday peak periods with Alternative 1 2040 – Full Buildout of the MIMP.

SOV Sensitivity

A sensitivity analysis of reduced SOV mode splits of 65 percent and 50 percent⁸ is provided below for purposes of estimating potential higher transit trips and associated impacts. Note that the estimate of vehicular trips is the highest when assuming the existing 2019 CTR SOV rate of 75 percent as evaluated above. Since this results in a conservative estimate of traffic vehicular operations, no additional vehicular operations analysis was completed with the reduced SOV percentages.

The change in SOV percentage was applied to the overall person trip generation of the campus. The Transportation Management Plan (TMP) which identifies the TMP goals for the campus apply only to staff of the institution and not to patients and visitors. However, as noted above it was assumed that the campus population follows the same general trend as the CTR survey. The following table summarizes the Alternative 1 person trip generation reflecting the SOV sensitivity analysis of both 65 percent and 50 percent compared to the 2019 CTR SOV rate of 75 percent.

Trip Generation	75% SOV ²			65% SOV ³			50% SOV ⁴					
	Mode Split	2040 – Full buildout of the MIMP	Total Alt 1 ¹	Mode Split	2040 – Full buildout of the MIMP	Total Alt 1	Mode Split	2040 – Full buildout of the MIMP	Total Alt 1 ¹			
Weekday AM Peak Hour												
Vehicle Trips		755	662	1,417	689	593	1,282	593	494	1,087		
Person Trips												
Walk or Bike Trips	2.5%	24	21	45	3%	29	25	53	4.5%	42	37	79
Transit Trips	7%	66	58	124	10%	94	82	176	15%	141	124	264
Other	1.5%	13	12	25	3%	29	25	53	3.5%	32	29	61
Person Trips by Vehicle	89%	836	734	1,570	84%	788	691	1,480	77%	723	635	1,358
Total	100%	939	824	1,763	100%	939	824	1,763	100%	939	824	1,763
Weekday PM Peak Hour												
Vehicle Trips		613	563	1,176	558	506	1,064	476	421	897		
Person Trips												
Walk or Bike Trips	2.5%	19	18	37	3%	23	21	44	4.5%	34	32	66
Transit Trips	7%	53	49	102	10%	76	70	146	15%	114	105	219
Other	1.5%	12	11	23	3%	23	21	44	3.5%	26	25	51
Person Trips by Vehicle	89%	678	624	1,302	84%	641	590	1,231	77%	587	541	1,128
Total	100%	762	701	1,463	100%	762	701	1,463	100%	762	701	1,463

Note: SOV = single occupancy vehicle

1. Total Alternative (Alt) 1 = 1,600,000 gsf

2. The 89 percent person trips by vehicle includes approximately 75 percent SOV and 14 percent associated with carpool and vanpool trips, resulting in a AVO of 1.1. The AVO of 1.1 was multiplied by the vehicles trips to determine the number of person trips by vehicle. The person trip distribution per the CTR was then applied to determine the total person trips.

3. The 84 percent person trips by vehicle includes approximately 65 percent SOV and 19 percent associated with carpool and vanpool trips, resulting in a AVO of 1.17. The AVO of 1.17 was multiplied by the vehicles trips to determine the number of person trips by vehicle. The person trip distribution per the CTR was then applied to determine the total person trips.

⁸ 50 percent SOV is consistent with the Major Institution goal identified in SMC 23.54.016 C.

4. The 77 percent person trips by vehicle includes approximately 50 percent SOV and 27 percent associated with carpool and vanpool trips, resulting in a AVO of 1.28. The AVO of 1.28 was multiplied by the vehicles trips to determine the number of person trips by vehicle. The person trip distribution per the CTR was then applied to determine the total person trips.

With the reduced SOV rates from 75 percent to 65 percent or 50 percent, Table 20 shows the transit trips are estimated to increase from 124 to 176 and 264 trips, respectively, in the AM peak hour and increase from 102 to 146 and 219 trips in the PM peak hour. The transit utilization with the higher transit usage for the lower SOV rates is reflected in the table below.

Table 21. Alternative 1 Transit Capacity Analysis – Sensitivity

Route # / Nearest Stop Location	Direction of Travel	Alternative 1 AM Peak Period Utilization ¹			Alternative 1 PM Peak Period Utilization		
		75% SOV	65% SOV	50% SOV	75% SOV	65% SOV	50% SOV
345 On Campus, north of eastern access point	S	50%	63%	83%	42%	48%	59%
	N	48%	59%	77%	49%	55%	66%
346 At the Meridian Ave N/ N 115th St Intersection	S	33%	33%	36%	37%	39%	40%
	N	37%	37%	40%	45%	47%	49%
40 At the SR 99/N 115th St Intersection	S	12%	12%	13%	22%	23%	23%
	N	19%	20%	22%	18%	18%	19%
E Line At the SR 99/N 115th St Intersection	N	37%	37%	38%	37%	37%	37%
	S	32%	32%	32%	38%	39%	39%

Note: SOV = single occupancy vehicle

1. Capacity for each route/stop assumed for the utilization calculation unchanged for Alternative 1 relative to No Action conditions for future (2040) conditions.

As shown in Table 21, the transit vehicle utilization for the 4 routes serving the campus would continue to have available capacity to accommodate additional riders during the weekday peak periods with Alternative 1 2040 – Full Buildout of the MIMP with reduced SOV of 65 and 50 percent.

Traffic Volumes

The Alternative 1 net new 2030 and 2040 vehicular trip generation (see Table 17) was assigned to the transportation network based on the vehicle trip distribution (see Figure 11). The Alternative 1 peak hour trip assignment is shown in Figure 14 and Figure 15 for the 2030 and 2040 conditions, respectively. The resulting Alternative 1 peak hour traffic volumes are shown on Figure 16 and Figure 17 for the 2030 and 2040 conditions, respectively.

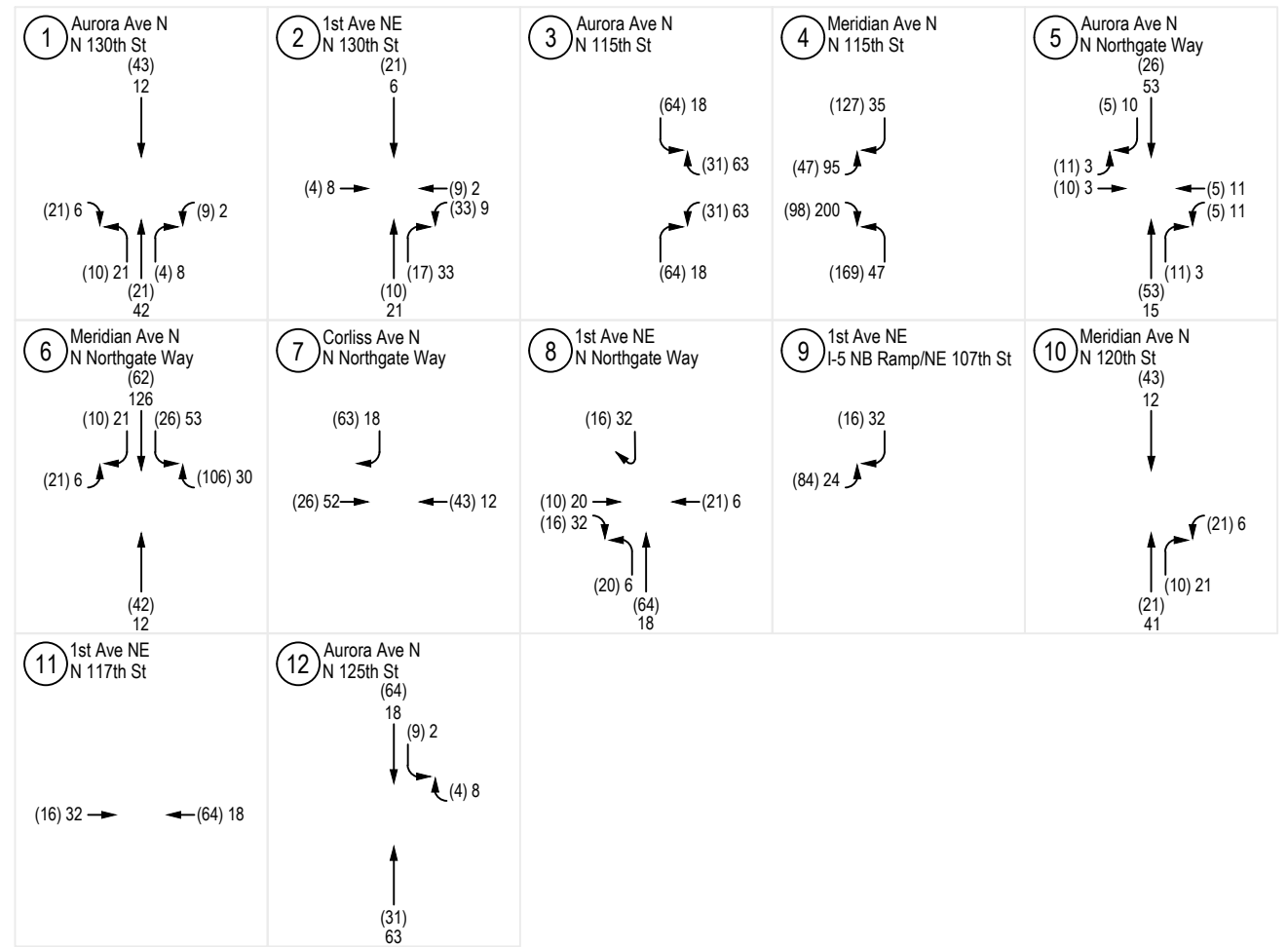
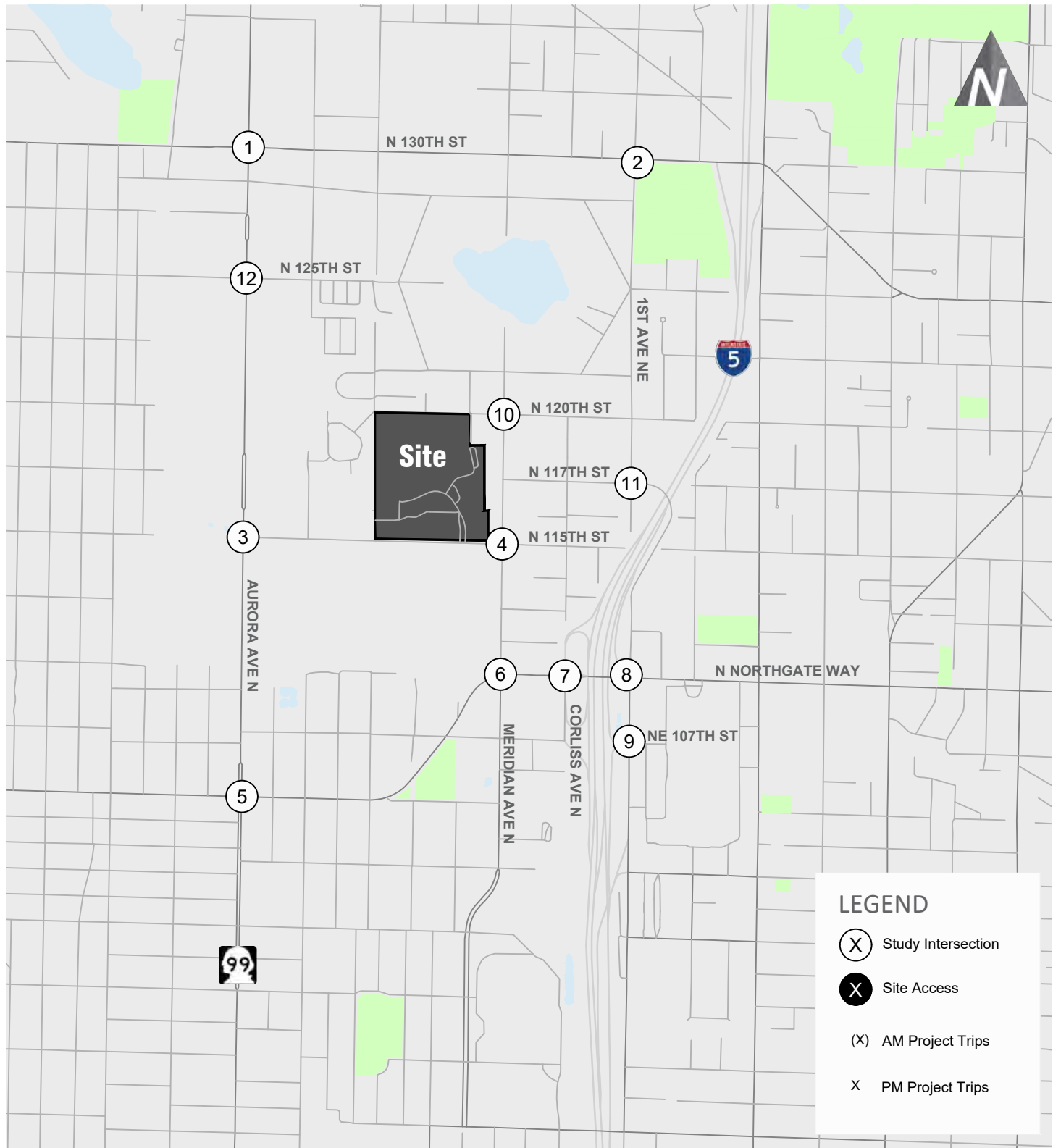

Alternative 1 2030 - Interim Buildout Peak Hour Trip Assignment

UWMC NW TDR

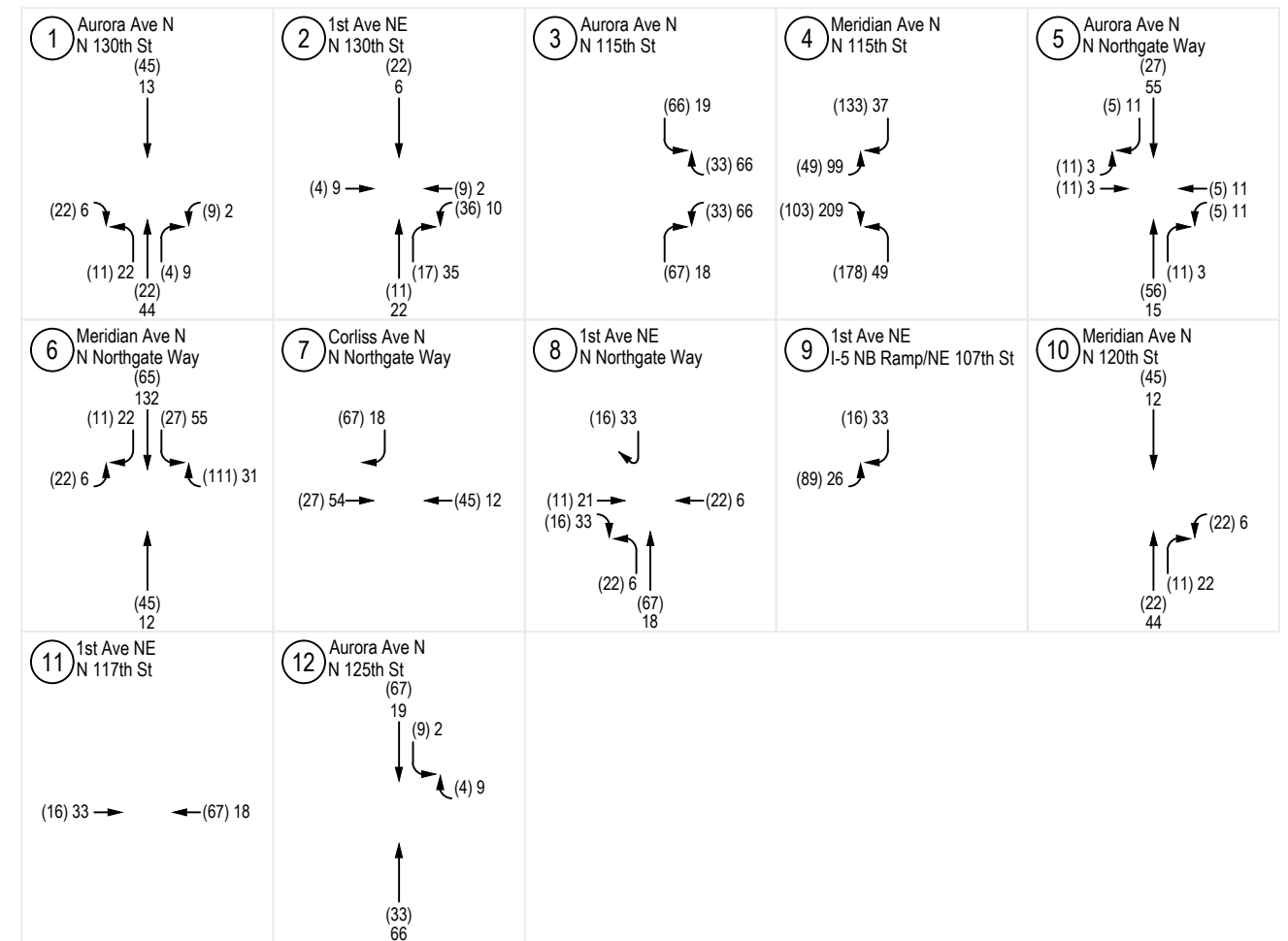
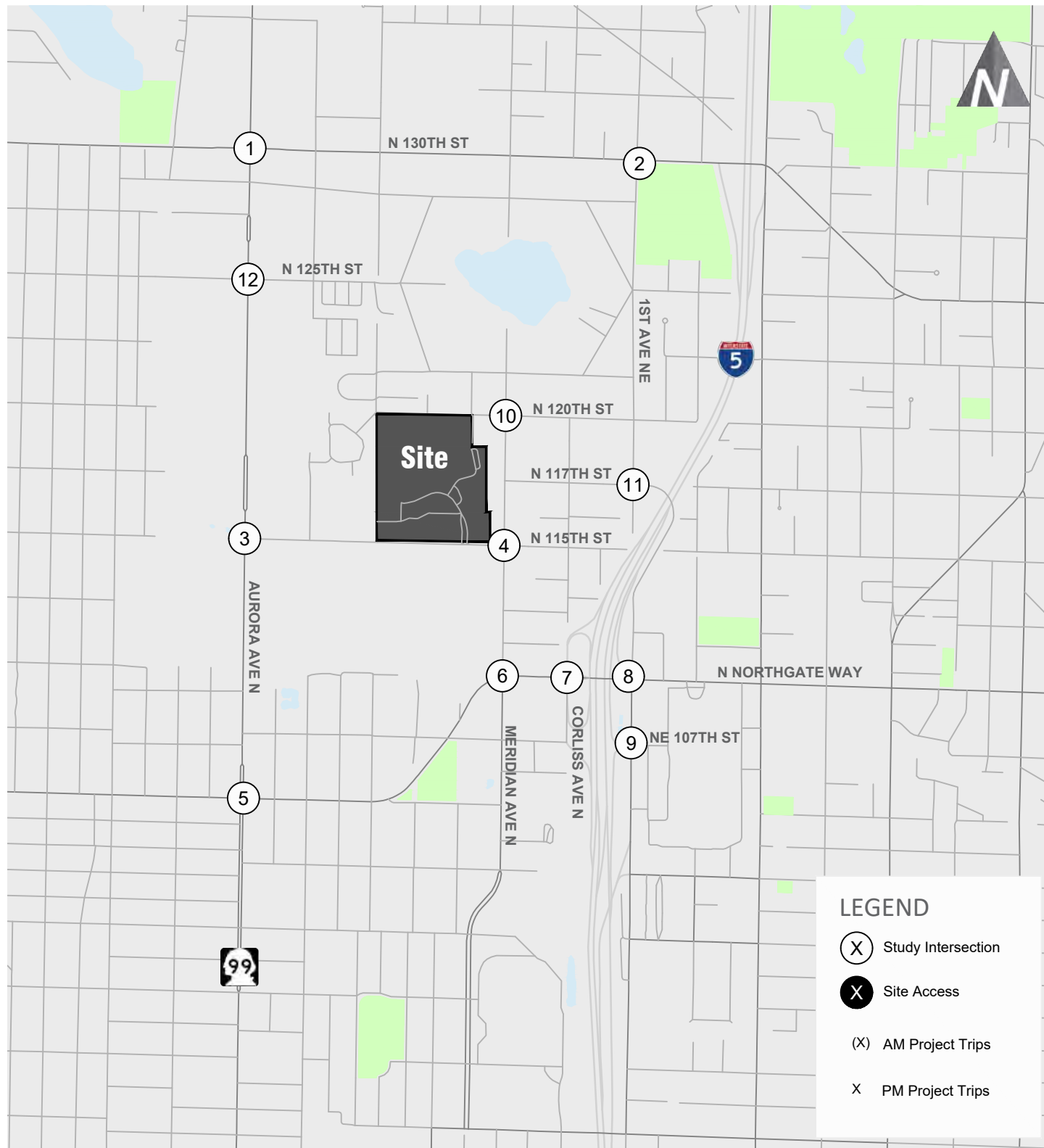

Alternative 1 2040 - Full Buildout of the MIMP Peak Hour Trip Assignment

UWMC NW TDR

FIGURE

15



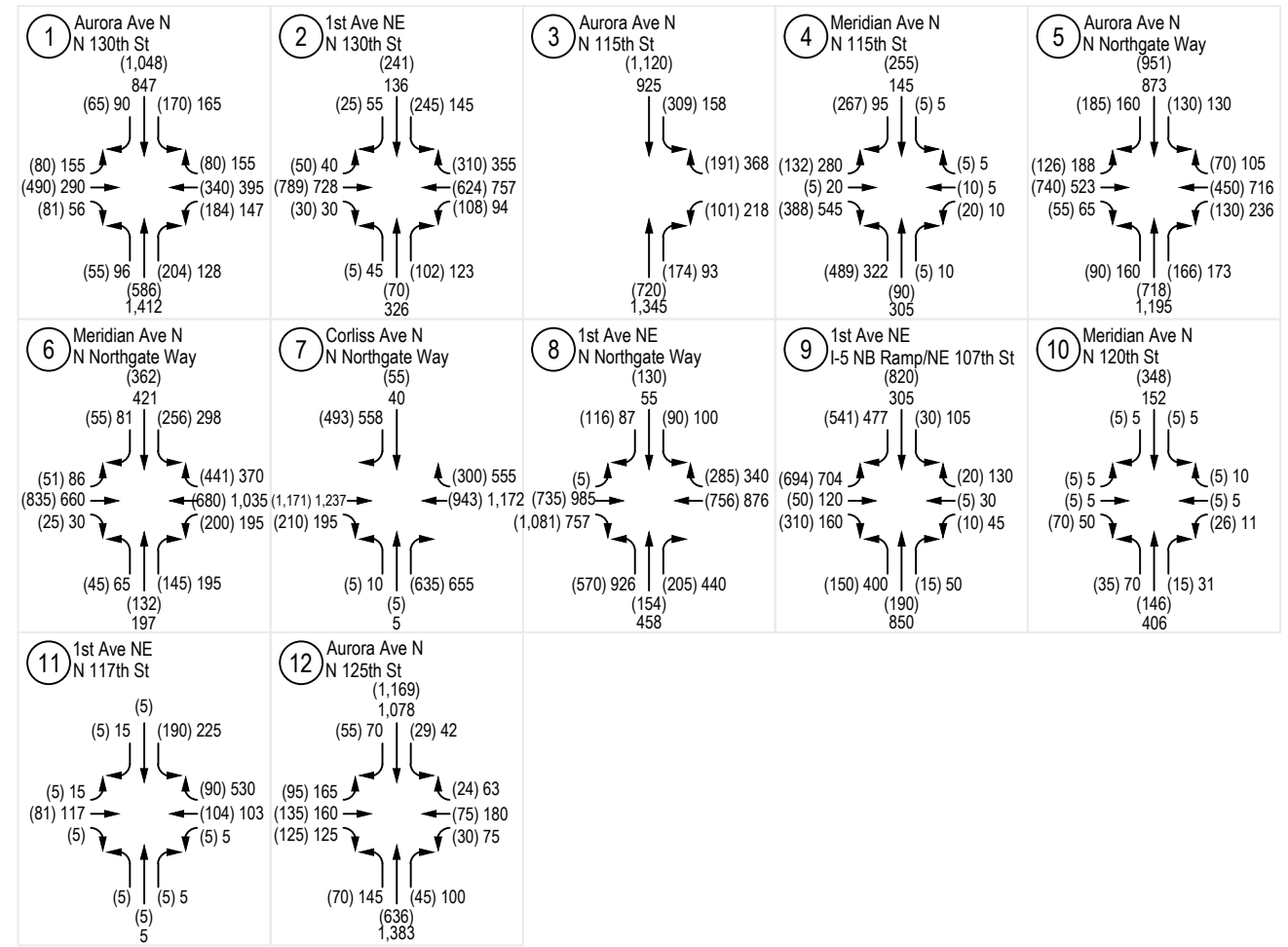
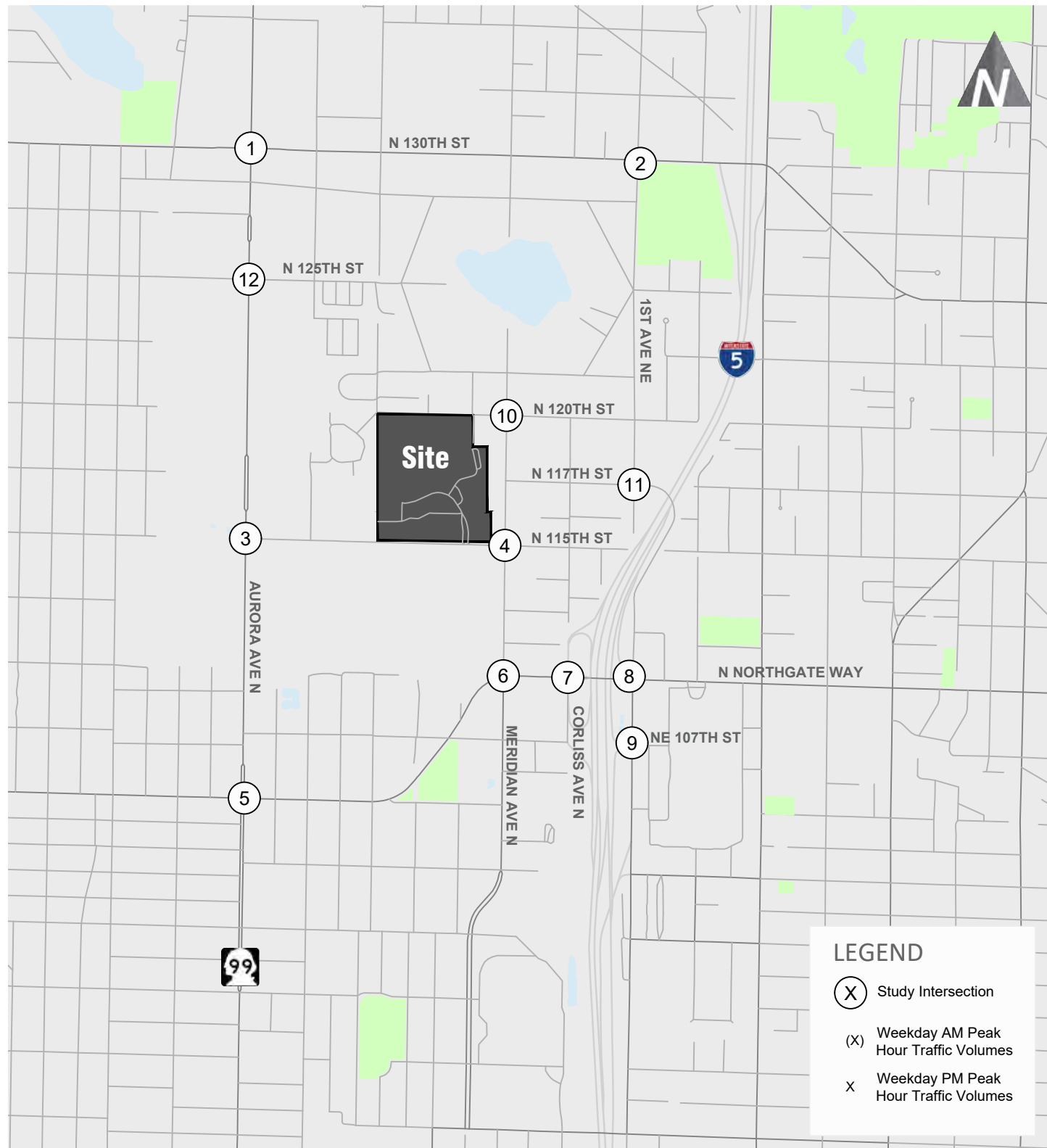

Alternative 1 2030 - Interim Buildout Weekday Peak Hour Traffic Volumes

UWMC NW TDR



FIGURE

16

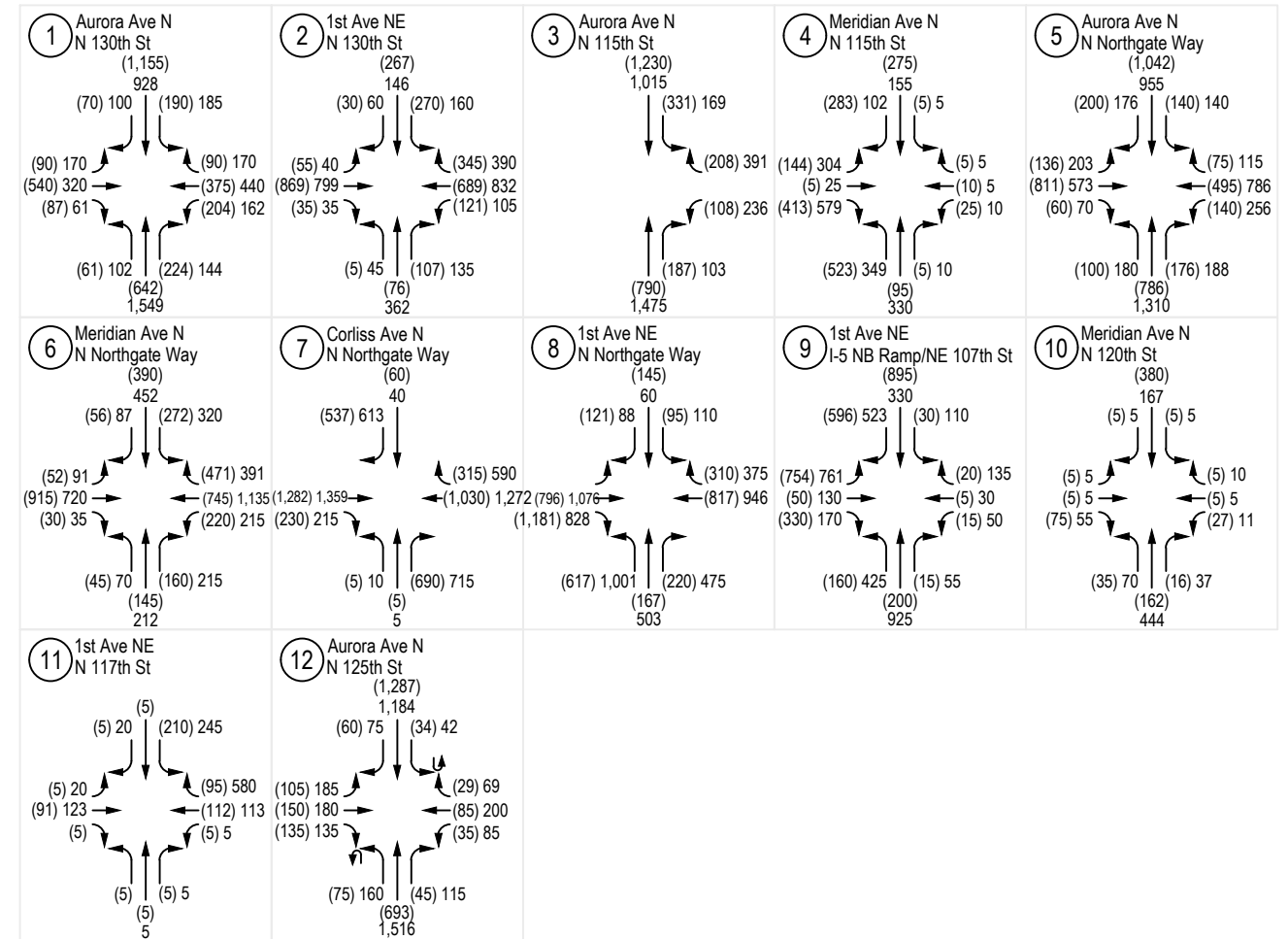
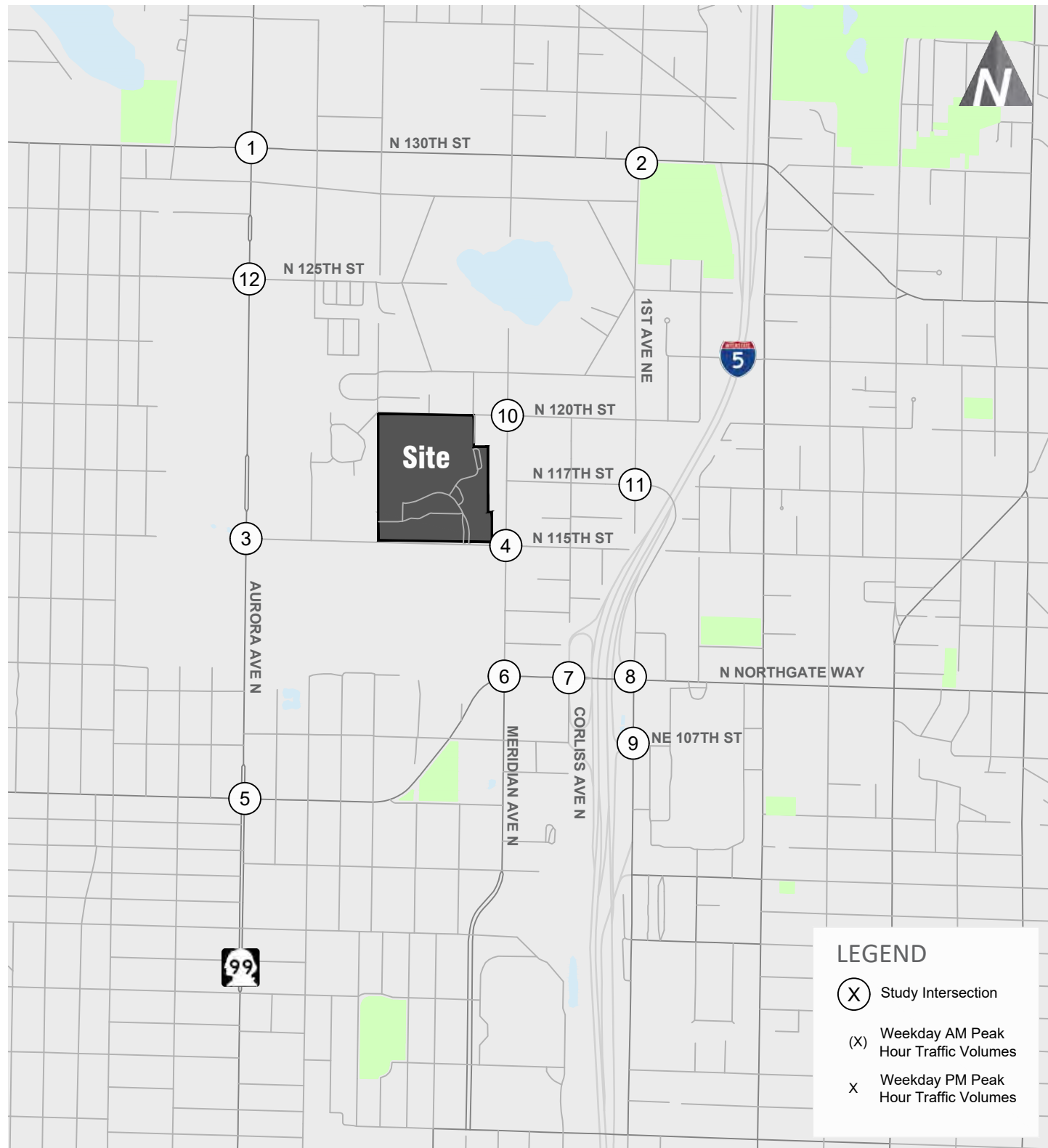

Alternative 1 2040 - Full Buildout of the MIMP Weekday Peak Hour Traffic Volumes

UWMC NW TDR

Traffic Operations

The Alternative 1 LOS analysis utilized the same methodology as the Existing and No Action conditions. All intersection parameters such as channelization, intersection control, and signal timing for the Alternative 1 are consistent with those used in the evaluation of future No Action conditions. A comparison of the No Action and Alternative 1 weekday peak hour operations at the off-site study intersections are summarized in Table 22 and Table 23 for the 2030 and 2040 conditions, respectively. Note that the site access points are reviewed separately given the proposed access additions with Alternative 1.

Table 22. Alternative 1 (2030) Weekday Peak Hour Off-Site Study Intersections LOS Summary

Intersection	Traffic Control	No Action – 2030			Alternative 1 – 2030 Interim Buildout		
		LOS ¹	Delay ²	WM ³	LOS	Delay	WM
AM Peak Hour							
1. Aurora Ave N/N 130th St	Signal	D	47	-	D	50	-
2. 1st Ave NE/N 130th St	Signal	D	37	-	D	43	-
3. Aurora Ave N/N 115th St	Signal	B	12	-	B	16	-
4. Meridian Ave N/N 115th St ⁴	AWSC	D	26	-	F	112	-
5. Aurora Ave N/N Northgate Way	Signal	D	51	-	D	52	-
6. Meridian Ave N/N Northgate Way	Signal	D	43	-	D	50	-
7. Corliss Ave N/N Northgate Way	Signal	B	10	-	B	12	-
8. 1st Ave NE/N Northgate Way	Signal	C	29	-	D	42	-
9. 1st Ave NE/I-5 NB Ramp/NE 107th St	Signal	E	58	-	E	63	-
10. Meridian Ave N/N 120th St ⁴	TWSC	B	14	WB	C	18	WB
11. 1st Ave NE/N 117th St	TWSC	A	9	-	A	10	-
12. Aurora Ave N/N 125th St	Signal	C	29	-	C	29	-
PM Peak Hour							
1. Aurora Ave N/N 130th St	Signal	D	44	-	D	45	-
2. 1st Ave NE/N 130th St	Signal	D	46	-	D	53	-
3. Aurora Ave N/N 115th St	Signal	B	18	-	D	36	-
4. Meridian Ave N/N 115th St ⁴	AWSC	E	39	-	F	150	-
5. Aurora Ave N/N Northgate Way	Signal	E	56	-	E	57	-
6. Meridian Ave N/N Northgate Way	Signal	C	33	-	D	46	-
7. Corliss Ave N/N Northgate Way	Signal	B	13	-	B	13	-
8. 1st Ave NE/N Northgate Way	Signal	F	97	-	F	99	-
9. 1st Ave NE/I-5 NB Ramp/NE 107th St	Signal	E	57	-	E	61	-
10. Meridian Ave N/N 120th St ⁴	TWSC	B	15	WB	C	18	WB
11. 1st Ave NE/N 117th St	TWSC	C	18	-	C	22	-
12. Aurora Ave N/N 125th St	Signal	D	40	-	D	40	-

Note: TWSC = Two-Way Stop Controlled. AWSC = All Way Stop Controlled **Bold** text indicates operating at LOS E or F if signalized or LOS F for stop controlled.

1. Level of Service (A – F) as defined by the *Highway Capacity Manual* (HCM) 6th Edition (TRB, 2016) as available.
2. Average delay per vehicle in seconds.
3. Worst movement reported for TWSC intersections. WB = westbound.
4. The operations assume all access to/from the campus via N 115th Street, consistent with access as it exists today. See additional discussion in the Site Access section below.

As described previously, the City of Seattle’s Comprehensive Plan does not define a LOS standard for individual intersections; however, the City generally recognizes LOS E and F as poor operations for signalized locations and LOS F for unsignalized locations. In addition, the project impacts may be considered significant if the intersection delay at a signalized intersection increases by 5 or more seconds.

As shown in Table 22, with the 2030 Alternative 1 interim buildout, the off-site study intersections are forecast to continue to operate at LOS D or better during the AM and PM peak hours with exception of 4 intersections which are discussed below.

Meridian Ave N/N 115th St – This all-way stop controlled intersection is forecast to degrade from operating at LOS D and E during the AM and PM peak hour No Action 2030 conditions, to operate at LOS F during the AM and PM peak hour Alternative 1 2030 interim buildout condition. This increase in delay at the all-way stop controlled intersection is identified as a significant impact which will require mitigation. Additional review of proposed mitigation and timing of improvements is provided in the Mitigation section.

Aurora Avenue N/N Northgate Way – This signalized intersection is forecast to operate at LOS D during the AM peak hour and LOS E in the PM peak hour under both future (2030) No Action and Alternative 1 2030 interim buildout conditions. The increase in delay is 1 second with Alternative 1 relative to No Action conditions during the PM peak hour when the intersection is forecast to operate at LOS E; therefore, Alternative 1 2030 Interim Buildout does not have a significant adverse impact at the intersection.

1st Avenue NE/N Northgate Way – This signalized intersection is forecast to operate at LOS D or better during the AM peak hour and LOS F in the PM peak hour under both future (2030) No Action and Alternative 1 2030 interim buildout conditions. The increase in delay is 1 second with Alternative 1 relative to No Action conditions during the PM peak hour when the intersection is forecast to operate at LOS F; therefore, Alternative 1 2030 Interim Buildout does not have a significant adverse impact at the intersection.

1st Avenue NE/I-5 NB Ramp/NE 107th Street – This signalized intersection is forecast to operate at LOS E during the AM and PM peak hours under both future (2030) No Action and Alternative 1 2030 interim buildout conditions. The increase in delay is approximately 4 seconds or less with Alternative 1 relative to No Action conditions during both peak hours; therefore, Alternative 1 2030 Interim Buildout does not have a significant adverse impact at the intersection.

Table 23. Alternative 1 (2040) Weekday Peak Hour Off-Site Study Intersections LOS Summary

Intersection	Traffic Control	No Action – 2040			Alternative 1 – 2040 Buildout		
		LOS ¹	Delay ²	WM ³	LOS	Delay	WM
AM Peak Hour							
1. Aurora Ave N/N 130th St	Signal	D	47	-	D	49	-
2. 1st Ave NE/N 130th St	Signal	D	40	-	D	48	-
3. Aurora Ave N/N 115th St	Signal	B	13	-	B	18	-
4. Meridian Ave N/N 115th St ⁴	AWSC	C	24	-	F	107	-
5. Aurora Ave N/N Northgate Way	Signal	D	44	-	D	44	-
6. Meridian Ave N/N Northgate Way	Signal	D	42	-	D	48	-
7. Corliss Ave N/N Northgate Way	Signal	B	13	-	B	16	-
8. 1st Ave NE/N Northgate Way	Signal	C	30	-	D	44	-
9. 1st Ave NE/I-5 NB Ramp/NE 107th St	Signal	E	67	-	E	70	-
10. Meridian Ave N/N 120th St ⁴	TWSC	B	13	WB	C	17	WB
11. 1st Ave NE/N 117th St	TWSC	A	9	-	A	9	-
12. Aurora Ave N/N 125th St	Signal	C	31	-	C	32	-
PM Peak Hour							
1. Aurora Ave N/N 130th St	Signal	D	49	-	D	49	-
2. 1st Ave NE/N 130th St	Signal	D	53	-	E	60	-
3. Aurora Ave N/N 115th St	Signal	B	18	-	C	33	-
4. Meridian Ave N/N 115th St ⁴	AWSC	E	37	-	F	145	-
5. Aurora Ave N/N Northgate Way	Signal	E	60	-	E	62	-
6. Meridian Ave N/N Northgate Way	Signal	D	42	-	D	55	-
7. Corliss Ave N/N Northgate Way	Signal	B	14	-	B	16	-
8. 1st Ave NE/N Northgate Way	Signal	F	103	-	F	107	-
9. 1st Ave NE/I-5 NB Ramp/NE 107th St	Signal	E	62	-	E	67	-
10. Meridian Ave N/N 120th St ⁴	TWSC	B	14	WB	C	17	WB
11. 1st Ave NE/N 117th St	TWSC	D	28	-	C	24	-
12. Aurora Ave N/N 125th St	Signal	D	47	-	D	43	-

Note: TWSC = Two-Way Stop Controlled. AWSC = All Way Stop Controlled **Bold** text indicates operating at LOS E or F if signalized or LOS F for stop controlled.

1. Level of Service (A – F) as defined by the *Highway Capacity Manual* (HCM) 6th Edition (TRB, 2016) as available.
2. Average delay per vehicle in seconds.
3. Worst movement reported for TWSC intersections. WB = westbound.
4. The operations assume all access to/from the campus via N 115th Street, consistent with access as it exists today. See additional discussion in Site Access section below.

Similar to the Alternative 1 2030 Interim Buildout, the off-site study intersections with Alternative 1 2040 Full Buildout of the MIMP are generally forecast to continue to operate at LOS D or better during the AM and PM peak hours with the exception of 5 intersections which are discussed below.

Meridian Ave N/N 115th St – This all-way stop controlled intersection is forecast to degrade from operating at LOS C and E during the AM and PM peak hour No Action 2040 conditions, to operate at LOS F during the AM and PM peak hour Alternative 1 2040 – full buildout of the MIMP condition. This increase in delay at the all-way stop controlled intersection is identified as a significant impact which will require mitigation. Additional review of proposed mitigation and timing of improvements is provided in the Mitigation section.

Aurora Avenue N/N Northgate Way – This signalized intersection is forecast to operate at LOS D during the AM peak hour and LOS E in the PM peak hour under both future (2040) No Action and Alternative 1 2040 full buildout of the MIMP conditions. The increase in delay is 1 second with Alternative 1 relative to No Action conditions during the PM peak hour when the intersection is forecast to operate at LOS E; therefore, Alternative 1 2040 – full buildout of the MIMP condition does not have a significant adverse impact at the intersection.

1st Avenue NE/N Northgate Way – This signalized intersection is forecast to operate at LOS D or better during the AM peak hour and LOS F in the PM peak hour under both future (2040) No Action and Alternative 1 2040 full buildout of the MIMP conditions. The increase in delay is approximately 4 seconds with Alternative 1 relative to No Action conditions during the PM peak hour when the intersection is forecast to operate at LOS F; therefore, Alternative 1 2040 – full buildout of the MIMP condition does not have a significant adverse impact at the intersection.

1st Avenue NE/I-5 NB Ramp/NE 107th Street – This signalized intersection is forecast to operate at LOS E during the AM and PM peak hours under both future (2040) No Action and Alternative 1 2040 full buildout of the MIMP conditions. The increase in delay is approximately 4 seconds or less with Alternative 1 relative to No Action conditions during both peak hours; therefore, Alternative 1 2040 – full buildout of the MIMP condition does not have a significant adverse impact at the intersection.

1st Avenue NE/N 130th Street – There is a proposed channelization revision along the N 130th Street corridor as part of the Vision Zero safety corridor project which prioritizes the implementation of non-motorized facilities including installing bicycle lanes along both sides of the road. This is accomplished by reducing N 130th Street from 4 vehicular lanes to a three-lane road (two through-lanes with a center two-way left turn lane) west of 1st Avenue NE. The reduced vehicular section results in the LOS degrading at the intersection, specifically the LOS at the intersection is forecast to degrade from operating at LOS D under future (2040) No Action weekday PM peak hour conditions to LOS E with Alternative 1. The increase in delay is approximately 7 seconds, exceeding the typical threshold of 5 seconds. Given the planned improvement at this location to reduce the vehicular capacity, prioritizing non-motorized, an improvement to increase vehicle capacity at this location is not recommended.

Also, note that minor reductions in delay comparing 2040 to 2030 conditions at some off-site study intersections is associated with the change in the PHF to 1.0 as described above, which reflects operations with an even distribution of vehicle demand throughout the hour consistent with travel patterns as congestion increases.

Site Access Review

As noted above, access for Alternative 1 would maintain the 2 existing access points along N 115th Street as well as include a third access point located via either N 115th Street or N 120th Street. The following describes assumptions related to these two options in more detail.

- **Access Option 1** (Third access via N 115th Street) – The N 115th Street access would be located between the 2 existing access points. The additional access was evaluated both as a stopped controlled intersection, similar to the other existing driveways, as well as a signalized driveway.⁹ Therefore, the shift in trips is limited to the access points along 115th, so no change at off-site study intersections.
- **Access Options 2** (Third access via N 120th Street) – By providing a third access on the north side of the site, there would be localized shift at the adjacent off-site study intersections; however, the general off-site distribution patterns as reflected in Figure 11 would be consistent. As shown in the distribution figure, the majority of trips are to/from the south. Additionally, the roadways north of the site are circuitous if destined for areas northeast or northwest of the campus. Navigating around Haller Lake is less convenient than connecting to the area street system to the south. Given these factors, the anticipated use of the northern access via N 120th Street is limited, estimated to be up to 15 percent of the total campus trips.

The location of the on-site parking supply has not been fully defined within the MIMP as it is dependent on where development on the campus actually occurs. For that reason, each option is evaluated with two possible parking scenarios; (a) equally distributed or (b) concentrated on the west side of the campus.

The LOS and 95th percentile queues of the worst movement of the stop-controlled access points were evaluated at the site access points focusing on the Alternative 1 2040 – Full Buildout of the MIMP

⁹ A signal warrant analysis was completed for the site access (see Appendix G) and was shown to be warranted. See Mitigation section below for additional details on methodology.

conditions (see Table 24 for Option 1 and Table 25 for Option 2). The AM and PM peak hour traffic volumes at the site access points for the Alternative 1 2040 conditions for the signalized and unsignalized scenarios for Option 1 are provided in Figure 18 and Option 2 are provided in Figure 19. Note that additional review of the 2030 conditions was conducted and the results included in Appendix H. The results of the 2030 analysis do not change the conclusions as presented for the full buildout analysis below or change the identified mitigation needs at the Meridian Avenue N/N 115th Street intersection (see Mitigation section below).

Table 24. Alternative 1 2040 Weekday Peak Hour Site Access LOS Access Summary (Option 1: 3rd access via N 115th St)

Intersection	AM Peak Hour						PM Peak Hour					
	TWSC ⁴			Signal ⁴			TWSC ⁴			Signal ⁴		
	LOS ¹	Delay ²	Queue ³	LOS	Delay	Queue	LOS	Delay	Queue	LOS	Delay	Queue
Parking Scenario – Evenly Distributed												
A. West Access/N 115th St	D	33	2	C	22	1	E	37	4	C	24	2
B. East Access/N 115th St	F	150	9	F	56	3	F	177	16	F	70	5
C. Central Access/N 115th St	F	65	6	A	7	-	F	96	11	A	9	-
Parking Scenario – West Concentrated												
A. West Access/N 115th St	D	29	2	D	27	2	D	30	4	D	33	3
B. East Access/N 115th St	F	162	8	F	54	3	F	178	14	F	69	5
C. Central Access/N 115th St	F	88	7	A	9	-	F	107	12	A	8	-

Note: TWSC = Two-Way Stop Controlled. **Bold** text indicates operating at LOS E or F if signalized or LOS F for TWSC.

1. Level of Service (A – F) as defined by the *Highway Capacity Manual* (HCM) 6th Edition (TRB, 2016).
2. Average delay per vehicle in seconds reported for the worst movement at the stop-controlled site access points.
3. 95th percentile queue reported in vehicles for the worst movement at the stop-controlled site access points.
4. Traffic control of 3rd access point.

As shown in Table 24, if the third access proposed via N 115th Street is unsignalized the three driveways operate with delays ranging between 29 and 178 seconds and 95th percentile queues ranging between 2 and 16 vehicles. Whereas, by signalizing the additional access, the two existing driveways improve to operating with delay between 22 and 70 seconds and queues between 1 and 5 vehicles and with the signalized access operating at LOS A. Note that the traffic signal is able to accommodate additional demand as compared with the unsignalized access which is why the adjacent unsignalized intersections reflect improve operations.

Table 25. Alternative 1 2040 Weekday Peak Hour Site Access LOS Access Summary (Option 2: 3rd access via N 120th St)

Intersection	AM Peak Hour			PM Peak Hour		
	LOS ¹	Delay ²	Queue ³	LOS	Delay	Queue
Parking Scenario – Evenly Distributed						
A. West Access/N 115th St	D	32	2	D	34	4
B. East Access/N 115th St	F	170	10	F	212	18
D. North Access/N 120th St	A	9	<1	A	9	<1
Parking Scenario – West Concentrated						
A. West Access/N 115th St	F	54	5	F	88	10
B. East Access/N 115th St	F	120	6	F	132	11
D. North Access/N 120th St	A	9	<1	A	9	<1

Note: TWSC = Two-Way Stop Controlled. **Bold** text indicates operating at LOS E or F if signalized or LOS F for TWSC.

1. Level of Service (A – F) as defined by the *Highway Capacity Manual* (HCM) 6th Edition (TRB, 2016).
2. Average delay per vehicle in seconds reported for the worst movement at the stop-controlled site access points.
3. 95th percentile queue reported in vehicles for the worst movement at the stop-controlled site access points.

With the third access via N 120th Street, Option 2, Table 25 shows that delay at the two existing driveways along N 115th Street operate more poorly than Option 1 being unsignalized. Consideration was given to not providing an additional access for the site; however, this results in challenges exiting the site

with access limited to the 2 existing access points via N 115th Street. Without additional access, the existing 2 access points would function more poorly than shown in Table 25 for Option 2 (via N 120th Street) which is estimated to have limited use (only 15 percent of campus trips).

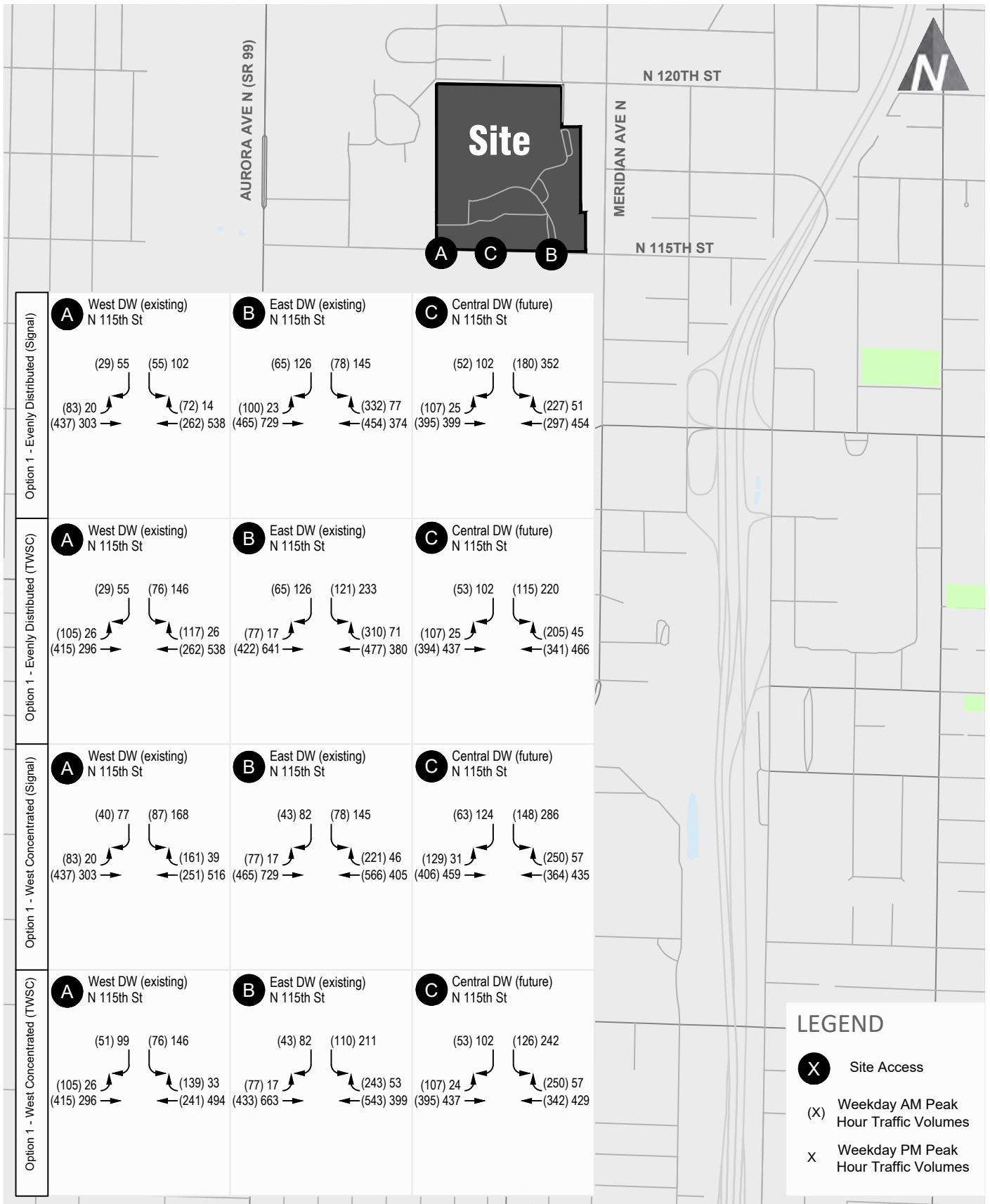

Alternative 1 2040 Full Buildout of MIMP Access Review Traffic Volumes - Option 1 FIGURE

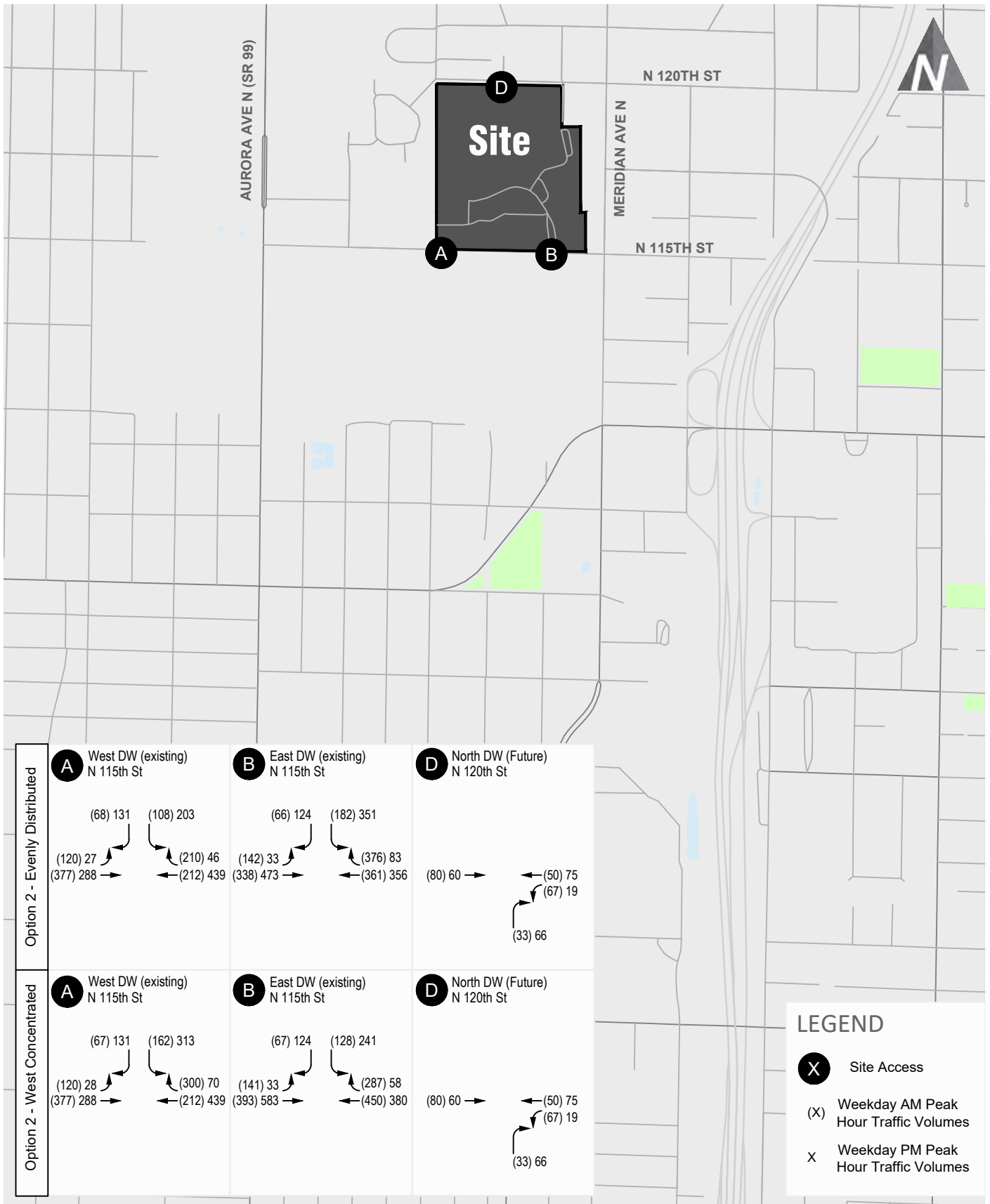

Alternative 1 2040 Full Buildout of MIMP Access Review Traffic Volumes - Option 2 FIGURE

Traffic Safety

As traffic volumes increase, traffic safety issues could increase proportionally. As shown in the trip generation table above (see Table 17), the total vehicle trips are forecast to increase with Action Alternative 1 relative to the No Action condition with the change in use and additional development. Based on the existing safety review, there was one HCL as well as 2 locations that averaged 10 or more collisions over the 3-year study period. There is a planned improvement along the Aurora Avenue N corridor within the vicinity of HCL location that includes safety improvements. The remaining 2 locations include the Meridian Avenue N and Corliss Avenue N intersections along Northgate Way which had predominantly rear end and entering at an angle collisions, respectively. Based on the assignment of vehicle trips and review of the existing collision history, no significant impacts from a safety perspective are anticipated at any of the study area intersections.

Loading

Campus deliveries are expected to continue to be managed at a campus-wide level with one or more loading docks. The future needs of the campus have been identified based on the existing demand rates and a targeted utilization of less than 40 percent. As noted above the current utilization is 35 percent and the campus has not indicated any operational issues. There are very few times through the day, based on observations that all three existing berths are utilized. While several berths were added with the BHTF project, the location of these may change as a result of the MIMP development plans.

With Alternative 1, the incremental increase in project size, relative to the No Action condition, is 835,457 sf. The master plan has identified a minimum of 9 active loading spaces; 1 additional active loading berth is planned as part of the MIMP. A summary of the forecast demand and utilization is included below in Table 26. The Existing and No Action conditions are included for comparative purposes.

Table 26. UW Medical Center – Northwest Loading Berth Utilization Study (MIMP)

Scenario	Size	Demand (minutes) ¹	Number of Loading Berths	Utilization
Existing	549,697 sf	621	3	35%
No Action	764,543 sf	866	8	18%
MIMP Alt #1	1,600,000	1796	9	33%

1. Demand expressed in minutes as identified above.

Applying the existing rates for the campus to the 1,600,000 sf total campus size, there is estimated to be approximately 1,796 min delivery-minutes or 85 deliveries per day. Assuming the loading berths operate for 10 hours per day, the total loading berths operation capacity under this scenario is 5,400 minutes (9 berths * 600 minutes per berth). Based on the 1,796 delivery-minutes, the percent utilization of the loading berths is 33 percent, under this scenario. This number shows that the 9 loading berths operating at 10 hours per day are more than enough to accommodate the deliveries made to the site and will utilize only 33 percent of their future capacity. The forecast utilization of 33 percent is less than the existing conditions. Expansion of the core delivery hours, or increasing the acceptable utilization could reduce the numbers of bays needed. The acceptable hours, in consideration of patient care, are dependent on the location of the dock relative to patient facilities. If the assumed delivery hours per day were increased, the number of loading berths could be reduced while still maintaining the same 33 percent utilization forecasted under the MIMP.

Construction Traffic

Alternative 1 would generate construction traffic (e.g. employees and trucks) associated with demolition, excavation, infrastructure and building construction, and landscaping. As noted above, the existing on-site loop road would be reconfigured and improved to serve as the main access route through the site. The construction activity throughout the duration of the project will vary, with the greatest daily trips occurring initially during the import/export phase. Following the import/export phase, activity shifts to construction of structures which typically have lower daily activity levels with workers arriving prior to the weekday AM

peak period and departing prior to the PM peak period. Construction haul routes and activities would be coordinated with City staff through a Construction Management Plan (CMP). Internal circulation routes for pedestrians and bicyclists as well as external connections to the City facilities will be provided during any construction activity. No major staging or closure of the City ROW is anticipated in the current development plans. Therefore, no significant construction traffic impacts are expected.

Impacts of Action Alternative 2

The development size of Alternative 2 is consistent with Alternative 1, such that the associated estimated trip generation and resulting impacts for Alternative 2 are consistent those identified for Alternative 1.

Impacts of Action Alternative 3

Transportation impacts under Alternative 3 will be similar to those described for Alternative 1 as there are no changes in development totals or development type. As identified in Alternatives 1 and 2, a third access is proposed. The preferred access under Alternative 3 is via N 115th Street.

Mitigation

This chapter presents mitigation measures that would offset or reduce potential impacts of the Action Alternatives. Mitigation measures identified are consistent for all three development alternatives.

Intersection Improvements

The **Meridian Avenue N/N 115th Street** all-way stop controlled intersection is forecast to degrade from operating at LOS D and E during the AM and PM peak hour No Action 2030 and 2040 conditions, to operate at LOS F during the AM and PM peak hour Alternative 1 2030 and 2040 conditions. This increase in delay at the all-way stop controlled intersection is identified as a significant impact which will require mitigation. Note that the operations for the Alternatives 2 and 3 conditions are consistent with Alternative 1. Mitigation of a traffic signal and roundabout are reviewed below as well as the timing of mitigation.

Traffic Signal – A signal warrant analysis was completed at the Meridian Avenue N/N 115th Street intersection based on the *HCS7 Software*. The four-hour and eight-hour signal warrants were evaluated. Warrants were run for the 2030 horizon year.¹⁰ Hourly traffic volumes were developed using the weekday PM peak hour traffic volumes and applying the hourly distribution from the National Cooperative Highway Research Program (NCHRP) Report 365 *Travel Estimation Techniques for Urban Planning*. A traffic signal should not be installed unless one or more of the signal warrants are met. The satisfaction of a traffic signal warrant or warrants does not itself require the installation of traffic control signal; however, locations that would meet a warrant or warrants and would benefit with operational and safety improvements are candidates for installation of a traffic signal. The signal warrant is included in Appendix G. The signal warrant is shown to be met and is proposed as mitigation at the intersection pending approval from SDOT.

The LOS with the proposed traffic signal installation at the Meridian Avenue N/N 115th Street intersection is summarized in Table 26 below.

Table 27. Meridian Ave N/N 115th St Weekday Peak Hour Mitigation LOS Summary

Analysis Year	Meridian Ave N/N 115th St No Action		Meridian Ave N/N 115th St Alternative 1 WITHOUT Mitigation		Meridian Ave N/N 115th St Alternative 1 WITH Mitigation (Traffic Signal)	
	LOS ¹	Delay ²	LOS	Delay	LOS	Delay
2030						
AM Peak Hour	D	26	F	112	E	76
PM Peak Hour	E	39	F	150	D	50
2040						
AM Peak Hour	C	24	F	107	E	71
PM Peak Hour	E	37	F	145	D	55

Note: TWSC = Two-Way Stop Controlled. **Bold** text indicates operating at LOS E or F if signalized or LOS F for TWSC.

1. Level of Service (A – F) as defined by the *Highway Capacity Manual* (HCM) 6th Edition (TRB, 2016).

2. Average delay per vehicle in seconds.

As shown in the table, the Meridian Avenue N/N 115th Street is forecast to operate at LOS D and LOS E in the PM and AM peak hours, respectively under future Alternative 1 conditions (both 2030 and 2040) with the installation of the traffic signal at the intersection. Comparing the operations under future Alternative 1 conditions with and without the traffic signal, delay is forecast to be reduced by 36 to 100 seconds. Note that feasibility of the addition of turn lanes as well was reviewed; however, in order to maintain the maneuverability of transit and surrounding the non-motorized facilities, no turn lanes were able to be accommodated within the available right-of-way.

¹⁰ The warrant was evaluated for the near-term horizon year as if warranted, it would also be warranted at the later horizon year as volumes are forecast to continue to grow.

Roundabout – Due to the right-of-way constraints at the Meridian Avenue N/N 115th Street intersection, a roundabout design is limited to a compact roundabout. Design vehicles of a bus and ambulance were reviewed at the intersection to review feasibility; however, both a bus and ambulance would need to drive over/through the center of the compact roundabout to make a northbound left-turn. These vehicle maneuvers are included in Appendix J. Therefore, a roundabout was not assumed a feasible mitigation option and a traffic signal is recommended.

Timing – The timing of the amount of development that would require the installation of the mitigation (recommended as a traffic signal) was reviewed. The allowable development prior to the Meridian Avenue N/N 115th Street intersection degrading to operate at LOS F is identified below by year (reviewed for a 10-year period). Note the annual background growth rate of 1.0 percent was applied per the identified year and all pipeline development and No Action development as assumed in the No Action condition analysis above was included in the forecasts. These years reflect years of occupancy of the development and represent the maximum amount of development allowable by that year prior requiring the mitigation. The allowable development¹¹ is shown to reduce over time prior to triggering the mitigation due to continued growth in background traffic conditions also adding vehicles and delay to the intersection.

- 2026 – up to 180,000 gsf
- 2027 – up to 170,000 gsf
- 2028 – up to 155,000 gsf
- 2029 – up to 140,000 gsf
- 2030 – up to 125,000 gsf
- 2031 – up to 110,000 gsf
- 2032 – up to 95,000 gsf
- 2033 – up to 80,000 gsf
- 2034 – up to 60,000 gsf
- 2035 – up to 45,000 gsf

Construction Management Plan (CMP)

As part of any future development to occur under this MIMP, the contractor would develop a Construction Management Plan (CMP) through coordination with City staff. Elements anticipated to be included in the CMP are identified below:

- Construction hours
- Noise generating activities
- Noise sensitive receivers
- Construction noise management
- Construction milestones
- Construction parking
- Right-of-Way use – (e.g. street closures, sidewalk closures, transit stop closures/relocations, etc.)
- Haul Routes

¹¹ Square footage shown is associated with occupiable areas and excludes infrastructure related development such as the central utility plant and parking.

Secondary and Cumulative Impacts

Secondary and cumulative impacts on area transportation system are included in the analysis of direct impacts. In addition, there is a potential for cumulative impacts due to the combined effects of traffic being generated by the proposed development and construction activities on the UWMC – Northwest Campus and in the surrounding vicinity. This potential impact could be mitigated by scheduling construction activities such that arrival and departure of construction traffic occurs outside the peak hours.

Significant and Unavoidable Adverse Impacts

As identified above, the LOS at the **1st Avenue NE/N 130th Street** intersection is forecast to degrade from operating at LOS D under future (2040) No Action weekday PM peak hour conditions to LOS E with Alternative 1, with an increase in delay of approximately 7 seconds. This exceeds the typical threshold of 5 seconds for identifying significant impacts. The reduced operations are associated with the proposed channelization revision along the N 130th Street corridor as part of the Vision Zero safety corridor project which prioritizes the implementation of non-motorized facilities including installing bicycle lanes along both sides of the road. This is accomplished by reducing N 130th Street from 4 vehicular lanes to a three-lane road (two through-lanes with a center two-way left turn lane) west of 1st Avenue NE and restricting right-turns on red. Given the planned improvement at this location to reduce the vehicular capacity, prioritizing non-motorized, an improvement to increase vehicular capacity at this location is not proposed.

No additional significant and unavoidable adverse impacts have been identified through this analysis.

Non-Motorized Connectivity Improvements

To improve connectivity to the transit stops located along Meridian Avenue N at N 120th Street, UWMC-Northwest will construct curb, gutter, and sidewalk along the south side of N 120th Street between Meridian Avenue N and west to the existing improved section. The section to be constructed is anticipated to generally match what was constructed along the UWMC northern frontage. Final plans and construction of the planned improvements are dependent upon future SDOT approval. These improvements would be triggered in the future when the hospital increases the patient occupiable area by greater than 250,000 net new gsf resulting in increases in patient volume and increased trip volume (i.e. size excludes the central utility plant and parking).

Appendix A Traffic Volumes

Aurora Ave N N 130th St



Peak Hour

Date: 01/24/2023
Count Period: 7:00 AM to 9:00 AM
Peak Hour: 8:00 AM to 9:00 AM

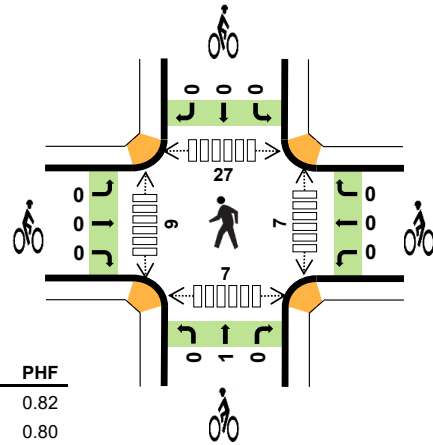
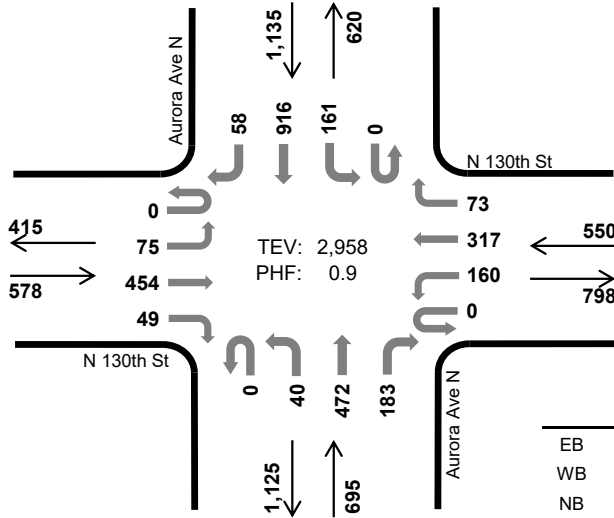

	HV %:	PHF
EB	3.6%	0.82
WB	4.9%	0.80
NB	7.2%	0.82
SB	5.9%	0.90
TOTAL	5.6%	0.90

Two-Hour Count Summaries

Interval Start	N 130th St Eastbound				N 130th St Westbound				Aurora Ave N Northbound				Aurora Ave N Southbound				15-min Total	Rolling One Hour	
	UT	LT	TH	RT	UT	LT	TH	RT	UT	LT	TH	RT	UT	LT	TH	RT			
7:00 AM	0	8	54	23	0	9	34	18	0	7	49	5	0	30	188	9	434	0	
7:15 AM	0	10	64	10	0	11	38	17	0	7	82	23	0	28	234	10	534	0	
7:30 AM	0	22	78	12	0	21	56	20	0	8	103	18	0	55	206	11	610	0	
7:45 AM	0	17	91	18	0	37	50	20	0	9	117	49	0	26	248	24	706	2,284	
8:00 AM	0	17	116	7	0	31	76	17	0	6	113	25	0	44	216	11	679	2,529	
8:15 AM	0	21	104	16	0	38	53	17	0	15	134	43	0	36	218	13	708	2,703	
8:30 AM	0	16	149	11	0	41	93	12	0	8	79	59	0	39	226	18	751	2,844	
8:45 AM	0	21	85	15	0	50	95	27	0	11	146	56	0	42	256	16	820	2,958	
Count Total	0	132	741	112	0	238	495	148	0	71	823	278	0	300	1,792	112	5,242	0	
Peak Hour	All	0	75	454	49	0	160	317	73	0	40	472	183	0	161	916	58	2,958	0
	HV	0	3	14	4	0	9	17	1	0	3	36	11	0	3	58	6	165	0
	HV%	-	4%	3%	8%	-	6%	5%	1%	-	8%	8%	6%	-	2%	6%	10%	6%	0

Note: Two-hour count summary volumes include heavy vehicles but exclude bicycles in overall count.

Interval Start	Heavy Vehicle Totals					Bicycles					Pedestrians (Crossing Leg)				
	EB	WB	NB	SB	Total	EB	WB	NB	SB	Total	East	West	North	South	Total
7:00 AM	5	7	3	12	27	0	0	0	0	0	5	0	2	0	7
7:15 AM	3	4	9	18	34	0	0	0	0	0	0	2	2	1	5
7:30 AM	1	11	8	14	34	0	0	0	0	0	1	0	0	2	3
7:45 AM	5	4	9	19	37	0	0	1	0	1	1	1	1	0	3
8:00 AM	4	6	13	20	43	0	0	0	0	0	2	2	3	0	7
8:15 AM	5	6	13	20	44	0	0	1	0	1	2	4	11	0	17
8:30 AM	9	8	8	11	36	0	0	0	0	0	1	0	7	5	13
8:45 AM	3	7	16	16	42	0	0	0	0	0	2	3	6	2	13
Count Total	35	53	79	130	297	0	0	2	0	2	14	12	32	10	68
Peak Hour	21	27	50	67	165	0	0	1	0	1	7	9	27	7	50

Two-Hour Count Summaries - Heavy Vehicles																		
Interval Start	N 130th St				N 130th St				Aurora Ave N				Aurora Ave N				15-min Total	Rolling One Hour
	Eastbound				Westbound				Northbound				Southbound					
	UT	LT	TH	RT	UT	LT	TH	RT	UT	LT	TH	RT	UT	LT	TH	RT		
7:00 AM	0	0	3	2	0	2	4	1	0	1	2	0	0	1	10	1	27	0
7:15 AM	0	0	2	1	0	1	2	1	0	1	5	3	0	1	15	2	34	0
7:30 AM	0	1	0	0	0	4	4	3	0	0	6	2	0	1	12	1	34	0
7:45 AM	0	0	4	1	0	1	2	1	0	1	4	4	0	1	17	1	37	132
8:00 AM	0	0	3	1	0	2	4	0	0	1	9	3	0	1	18	1	43	148
8:15 AM	0	1	2	2	0	3	2	1	0	1	10	2	0	1	17	2	44	158
8:30 AM	0	2	6	1	0	1	7	0	0	0	5	3	0	1	7	3	36	160
8:45 AM	0	0	3	0	0	3	4	0	0	1	12	3	0	0	16	0	42	165
Count Total	0	4	23	8	0	17	29	7	0	6	53	20	0	7	112	11	297	0
Peak Hour	0	3	14	4	0	9	17	1	0	3	36	11	0	3	58	6	165	0
Two-Hour Count Summaries - Bikes																		
Interval Start	N 130th St			N 130th St			Aurora Ave N			Aurora Ave N			15-min Total	Rolling One Hour				
	Eastbound			Westbound			Northbound			Southbound								
	LT	TH	RT	LT	TH	RT	LT	TH	RT	LT	TH	RT						
7:00 AM	0	0	0	0	0	0	0	0	0	0	0	0	0	0	0	0	0	0
7:15 AM	0	0	0	0	0	0	0	0	0	0	0	0	0	0	0	0	0	0
7:30 AM	0	0	0	0	0	0	0	0	0	0	0	0	0	0	0	0	0	0
7:45 AM	0	0	0	0	0	0	0	0	0	1	0	0	0	0	0	0	1	1
8:00 AM	0	0	0	0	0	0	0	0	0	0	0	0	0	0	0	0	0	1
8:15 AM	0	0	0	0	0	0	0	0	0	1	0	0	0	0	0	0	1	2
8:30 AM	0	0	0	0	0	0	0	0	0	0	0	0	0	0	0	0	0	2
8:45 AM	0	0	0	0	0	0	0	0	0	0	0	0	0	0	0	0	0	1
Count Total	0	0	0	0	0	0	0	0	0	2	0	0	0	0	0	0	2	0
Peak Hour	0	0	0	0	0	0	0	0	0	1	0	0	0	0	0	0	1	0
<i>Note: U-Turn volumes for bikes are included in Left-Turn, if any.</i>																		

Aurora Ave N N 130th St



Date: 01/24/2023
 Count Period: 4:00 PM to 6:00 PM
 Peak Hour: 5:00 PM to 6:00 PM

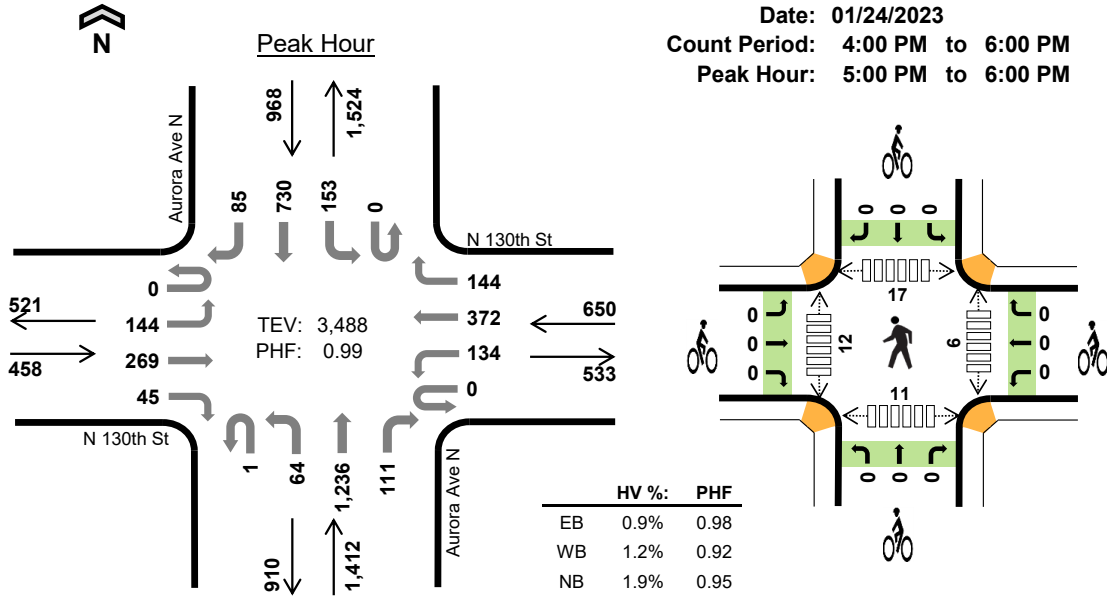

Two-Hour Count Summaries

Interval Start	N 130th St Eastbound				N 130th St Westbound				Aurora Ave N Northbound				Aurora Ave N Southbound				15-min Total	Rolling One Hour	
	UT	LT	TH	RT	UT	LT	TH	RT	UT	LT	TH	RT	UT	LT	TH	RT			
4:00 PM	0	40	89	11	0	35	94	30	0	10	268	26	0	36	206	17	862	0	
4:15 PM	0	27	62	14	0	40	76	44	1	17	282	30	0	32	149	17	791	0	
4:30 PM	0	35	57	11	0	42	77	32	1	12	297	30	0	30	173	23	820	0	
4:45 PM	0	39	80	10	0	38	110	35	0	24	255	32	0	41	179	15	858	3,331	
5:00 PM	0	28	72	9	0	37	86	35	0	20	317	24	0	33	200	24	885	3,354	
5:15 PM	0	36	68	13	0	35	102	39	0	13	291	20	0	46	183	20	866	3,429	
5:30 PM	0	37	66	13	0	30	96	29	1	14	309	31	0	42	189	18	875	3,484	
5:45 PM	0	43	63	10	0	32	88	41	0	17	319	36	0	32	158	23	862	3,488	
Count Total	0	285	557	91	0	289	729	285	3	127	2,338	229	0	292	1,437	157	6,819	0	
Peak Hour	All	0	144	269	45	0	134	372	144	1	64	1,236	111	0	153	730	85	3,488	0
	HV	0	1	2	1	0	1	5	2	0	1	23	3	0	0	24	0	63	0
	HV%	-	1%	1%	2%	-	1%	1%	1%	0%	2%	2%	3%	-	0%	3%	0%	2%	0

Note: Two-hour count summary volumes include heavy vehicles but exclude bicycles in overall count.

Interval Start	Heavy Vehicle Totals					Bicycles					Pedestrians (Crossing Leg)				
	EB	WB	NB	SB	Total	EB	WB	NB	SB	Total	East	West	North	South	Total
4:00 PM	7	2	15	7	31	0	0	0	0	0	15	9	13	11	48
4:15 PM	5	1	11	11	28	0	0	0	0	0	3	6	9	6	24
4:30 PM	1	3	11	5	20	0	0	0	0	0	5	1	2	7	15
4:45 PM	4	5	6	5	20	0	0	0	0	0	6	5	8	4	23
5:00 PM	2	3	13	10	28	0	0	0	0	0	5	8	5	2	20
5:15 PM	1	3	3	3	10	0	0	0	0	0	1	1	3	3	8
5:30 PM	0	1	7	5	13	0	0	0	0	0	0	3	3	2	8
5:45 PM	1	1	4	6	12	0	0	0	0	0	0	0	6	4	10
Count Total	21	19	70	52	162	0	0	0	0	0	35	33	49	39	156
Peak Hour	4	8	27	24	63	0	0	0	0	0	6	12	17	11	46

Two-Hour Count Summaries - Heavy Vehicles																		
Interval Start	N 130th St				N 130th St				Aurora Ave N				Aurora Ave N				15-min Total	Rolling One Hour
	Eastbound				Westbound				Northbound				Southbound					
	UT	LT	TH	RT	UT	LT	TH	RT	UT	LT	TH	RT	UT	LT	TH	RT		
4:00 PM	0	0	6	1	0	1	1	0	0	2	12	1	0	0	6	1	31	0
4:15 PM	0	0	5	0	0	0	0	1	0	0	10	1	0	0	10	1	28	0
4:30 PM	0	0	1	0	0	1	1	1	0	0	9	2	0	0	5	0	20	0
4:45 PM	0	0	3	1	0	3	0	2	0	1	5	0	0	1	4	0	20	99
5:00 PM	0	1	1	0	0	1	2	0	0	0	13	0	0	0	10	0	28	96
5:15 PM	0	0	1	0	0	0	2	1	0	0	3	0	0	0	3	0	10	78
5:30 PM	0	0	0	0	0	0	0	1	0	0	6	1	0	0	5	0	13	71
5:45 PM	0	0	0	1	0	0	1	0	0	1	1	2	0	0	6	0	12	63
Count Total	0	1	17	3	0	6	7	6	0	4	59	7	0	1	49	2	162	0
Peak Hour	0	1	2	1	0	1	5	2	0	1	23	3	0	0	24	0	63	0

Two-Hour Count Summaries - Bikes																		
Interval Start	N 130th St			N 130th St			Aurora Ave N			Aurora Ave N			15-min Total	Rolling One Hour				
	Eastbound			Westbound			Northbound			Southbound								
	LT	TH	RT	LT	TH	RT	LT	TH	RT	LT	TH	RT						
4:00 PM	0	0	0	0	0	0	0	0	0	0	0	0	0	0	0	0	0	0
4:15 PM	0	0	0	0	0	0	0	0	0	0	0	0	0	0	0	0	0	0
4:30 PM	0	0	0	0	0	0	0	0	0	0	0	0	0	0	0	0	0	0
4:45 PM	0	0	0	0	0	0	0	0	0	0	0	0	0	0	0	0	0	0
5:00 PM	0	0	0	0	0	0	0	0	0	0	0	0	0	0	0	0	0	0
5:15 PM	0	0	0	0	0	0	0	0	0	0	0	0	0	0	0	0	0	0
5:30 PM	0	0	0	0	0	0	0	0	0	0	0	0	0	0	0	0	0	0
5:45 PM	0	0	0	0	0	0	0	0	0	0	0	0	0	0	0	0	0	0
Count Total	0	0	0	0	0	0	0	0	0	0	0	0	0	0	0	0	0	0
Peak Hour	0	0	0	0	0	0	0	0	0	0	0	0	0	0	0	0	0	0

Note: U-Turn volumes for bikes are included in Left-Turn, if any.

1st Ave NE N 130th St



Peak Hour

Date: 01/24/2023
Count Period: 7:00 AM to 9:00 AM
Peak Hour: 8:00 AM to 9:00 AM

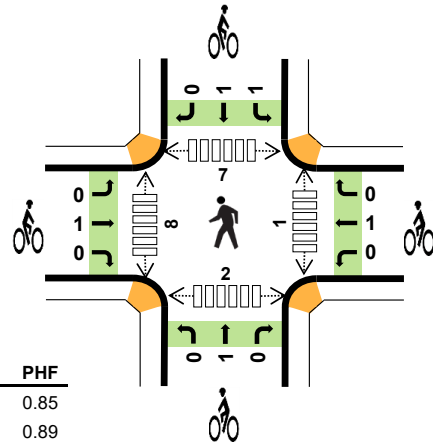
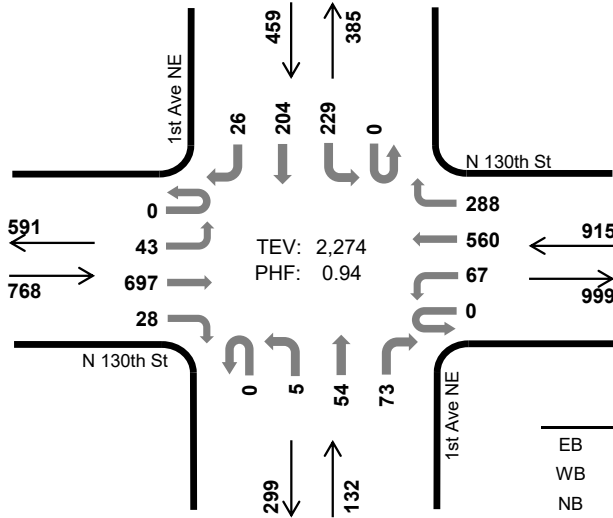

	HV %:	PHF
EB	3.4%	0.85
WB	3.0%	0.89
NB	3.8%	0.87
SB	1.7%	0.89
TOTAL	2.9%	0.94

Two-Hour Count Summaries

Interval Start	N 130th St Eastbound				N 130th St Westbound				1st Ave NE Northbound				1st Ave NE Southbound				15-min Total	Rolling One Hour	
	UT	LT	TH	RT	UT	LT	TH	RT	UT	LT	TH	RT	UT	LT	TH	RT			
7:00 AM	0	2	100	3	0	10	70	21	0	1	6	9	0	17	28	7	274	0	
7:15 AM	0	3	147	6	0	3	83	20	0	0	11	23	0	29	32	4	361	0	
7:30 AM	0	7	185	7	0	17	112	38	0	1	23	16	0	47	27	6	486	0	
7:45 AM	0	14	155	9	0	17	95	63	0	5	30	16	0	37	49	6	496	1,617	
8:00 AM	0	19	201	7	0	13	129	96	0	0	17	18	0	59	40	6	605	1,948	
8:15 AM	0	10	168	8	0	21	128	108	0	2	10	14	0	51	41	6	567	2,154	
8:30 AM	0	8	147	5	0	15	165	56	0	2	14	22	0	58	60	9	561	2,229	
8:45 AM	0	6	181	8	0	18	138	28	0	1	13	19	0	61	63	5	541	2,274	
Count Total	0	69	1,284	53	0	114	920	430	0	12	124	137	0	359	340	49	3,891	0	
Peak Hour	All	0	43	697	28	0	67	560	288	0	5	54	73	0	229	204	26	2,274	0
	HV	0	0	26	0	0	0	24	3	0	1	1	3	0	1	5	2	66	0
	HV%	-	0%	4%	0%	-	0%	4%	1%	-	20%	2%	4%	-	0%	2%	8%	3%	0

Note: Two-hour count summary volumes include heavy vehicles but exclude bicycles in overall count.

Interval Start	Heavy Vehicle Totals					Bicycles					Pedestrians (Crossing Leg)				
	EB	WB	NB	SB	Total	EB	WB	NB	SB	Total	East	West	North	South	Total
7:00 AM	7	8	0	1	16	0	0	0	0	0	0	1	0	0	1
7:15 AM	7	5	2	3	17	0	0	0	0	0	0	0	1	1	2
7:30 AM	11	11	1	4	27	0	1	0	3	4	0	2	0	0	2
7:45 AM	8	7	0	4	19	0	0	0	0	0	2	0	0	0	2
8:00 AM	3	10	2	1	16	0	0	0	2	2	1	2	2	0	5
8:15 AM	8	9	3	5	25	0	1	1	0	2	0	5	3	2	10
8:30 AM	6	5	0	1	12	1	0	0	0	1	0	1	2	0	3
8:45 AM	9	3	0	1	13	0	0	0	0	0	0	0	0	0	0
Count Total	59	58	8	20	145	1	2	1	5	9	3	11	8	3	25
Peak Hour	26	27	5	8	66	1	1	1	2	5	1	8	7	2	18

Two-Hour Count Summaries - Heavy Vehicles																		
Interval Start	N 130th St				N 130th St				1st Ave NE				1st Ave NE				15-min Total	Rolling One Hour
	Eastbound				Westbound				Northbound				Southbound					
	UT	LT	TH	RT	UT	LT	TH	RT	UT	LT	TH	RT	UT	LT	TH	RT		
7:00 AM	0	0	7	0	0	1	5	2	0	0	0	0	0	1	0	0	16	0
7:15 AM	0	1	6	0	0	0	4	1	0	0	0	2	0	1	0	2	17	0
7:30 AM	0	0	10	1	0	2	8	1	0	0	1	0	0	1	2	1	27	0
7:45 AM	0	0	8	0	0	1	5	1	0	0	0	0	0	1	2	1	19	79
8:00 AM	0	0	3	0	0	0	8	2	0	0	0	2	0	0	1	0	16	79
8:15 AM	0	0	8	0	0	0	9	0	0	1	1	1	0	1	2	2	25	87
8:30 AM	0	0	6	0	0	0	5	0	0	0	0	0	0	0	1	0	12	72
8:45 AM	0	0	9	0	0	0	2	1	0	0	0	0	0	0	1	0	13	66
Count Total	0	1	57	1	0	4	46	8	0	1	2	5	0	5	9	6	145	0
Peak Hour	0	0	26	0	0	0	24	3	0	1	1	3	0	1	5	2	66	0

Two-Hour Count Summaries - Bikes																		
Interval Start	N 130th St			N 130th St			1st Ave NE			1st Ave NE			15-min Total	Rolling One Hour				
	Eastbound			Westbound			Northbound			Southbound								
	LT	TH	RT	LT	TH	RT	LT	TH	RT	LT	TH	RT						
7:00 AM	0	0	0	0	0	0	0	0	0	0	0	0	0	0	0	0	0	0
7:15 AM	0	0	0	0	0	0	0	0	0	0	0	0	0	0	0	0	0	0
7:30 AM	0	0	0	0	0	0	1	0	0	0	0	0	0	3	0	0	4	0
7:45 AM	0	0	0	0	0	0	0	0	0	0	0	0	0	0	0	0	0	4
8:00 AM	0	0	0	0	0	0	0	0	0	0	0	0	1	1	0	2	6	6
8:15 AM	0	0	0	0	1	0	0	0	1	0	0	0	0	0	0	0	2	8
8:30 AM	0	1	0	0	0	0	0	0	0	0	0	0	0	0	0	0	1	5
8:45 AM	0	0	0	0	0	0	0	0	0	0	0	0	0	0	0	0	0	5
Count Total	0	1	0	0	1	1	0	0	1	0	0	1	4	0	0	0	9	0
Peak Hour	0	1	0	0	1	0	0	0	1	0	0	1	1	0	0	0	5	0

Note: U-Turn volumes for bikes are included in Left-Turn, if any.



1st Ave NE N 130th St

Date: 01/24/2023

Count Period: 4:00 PM to 6:00 PM

Peak Hour: 4:45 PM to 5:45 PM

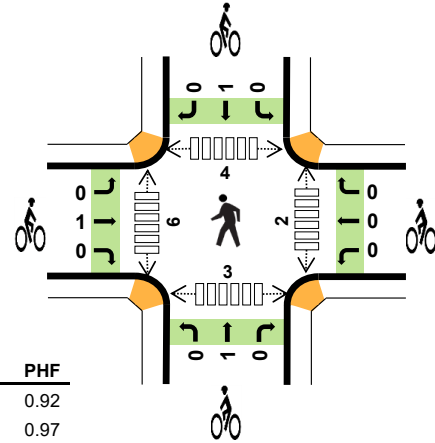
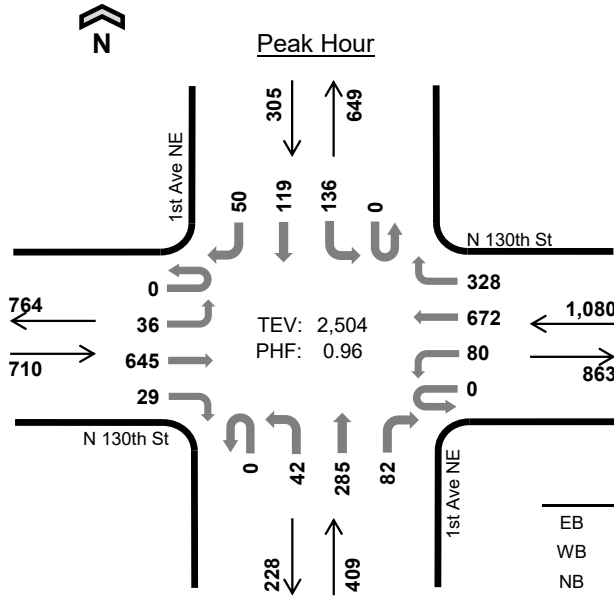

	HV %:	PHF
EB	1.1%	0.92
WB	1.0%	0.97
NB	1.2%	0.96
SB	0.3%	0.73
TOTAL	1.0%	0.96

Two-Hour Count Summaries

Interval Start	N 130th St Eastbound				N 130th St Westbound				1st Ave NE Northbound				1st Ave NE Southbound				15-min Total	Rolling One Hour	
	UT	LT	TH	RT	UT	LT	TH	RT	UT	LT	TH	RT	UT	LT	TH	RT			
4:00 PM	0	9	146	7	0	9	152	58	0	5	55	16	0	46	28	6	537	0	
4:15 PM	0	12	150	4	0	31	165	55	0	7	60	28	0	34	23	11	580	0	
4:30 PM	0	7	157	7	0	17	150	77	0	14	64	17	0	36	20	7	573	0	
4:45 PM	0	8	151	8	0	25	171	82	0	9	68	24	0	43	42	19	650	2,340	
5:00 PM	0	12	167	6	0	23	168	83	0	8	75	23	0	32	35	10	642	2,445	
5:15 PM	0	9	177	7	0	18	172	89	0	12	68	16	0	31	17	12	628	2,493	
5:30 PM	0	7	150	8	0	14	161	74	0	13	74	19	0	30	25	9	584	2,504	
5:45 PM	0	11	157	5	1	26	166	60	0	18	53	16	0	20	26	10	569	2,423	
Count Total	0	75	1,255	52	1	163	1,305	578	0	86	517	159	0	272	216	84	4,763	0	
Peak Hour	All	0	36	645	29	0	80	672	328	0	42	285	82	0	136	119	50	2,504	0
	HV	0	0	8	0	0	0	11	0	0	1	3	1	0	0	0	1	25	0
	HV%	-	0%	1%	0%	-	0%	2%	0%	-	2%	1%	1%	-	0%	0%	2%	1%	0

Note: Two-hour count summary volumes include heavy vehicles but exclude bicycles in overall count.

Interval Start	Heavy Vehicle Totals					Bicycles					Pedestrians (Crossing Leg)				
	EB	WB	NB	SB	Total	EB	WB	NB	SB	Total	East	West	North	South	Total
4:00 PM	8	3	1	3	15	0	0	0	0	0	0	6	2	1	9
4:15 PM	9	1	5	2	17	1	0	0	1	2	1	3	1	5	10
4:30 PM	7	6	2	0	15	0	1	1	0	2	0	1	1	1	3
4:45 PM	3	5	0	0	8	0	0	0	1	1	0	0	1	1	2
5:00 PM	2	3	2	1	8	1	0	0	0	1	1	2	1	1	5
5:15 PM	0	2	2	0	4	0	0	0	0	0	1	1	1	0	3
5:30 PM	3	1	1	0	5	0	0	1	0	1	0	3	1	1	5
5:45 PM	1	0	0	2	3	1	0	0	0	1	0	7	0	3	10
Count Total	33	21	13	8	75	3	1	2	2	8	3	23	8	13	47
Peak Hour	8	11	5	1	25	1	0	1	1	3	2	6	4	3	15

Two-Hour Count Summaries - Heavy Vehicles																		
Interval Start	N 130th St				N 130th St				1st Ave NE				1st Ave NE				15-min Total	Rolling One Hour
	Eastbound				Westbound				Northbound				Southbound					
	UT	LT	TH	RT	UT	LT	TH	RT	UT	LT	TH	RT	UT	LT	TH	RT		
4:00 PM	0	0	8	0	0	0	3	0	0	0	1	0	0	1	1	1	15	0
4:15 PM	0	0	9	0	0	0	1	0	0	0	1	4	0	2	0	0	17	0
4:30 PM	0	0	7	0	0	1	4	1	0	0	2	0	0	0	0	0	15	0
4:45 PM	0	0	3	0	0	0	5	0	0	0	0	0	0	0	0	0	8	55
5:00 PM	0	0	2	0	0	0	3	0	0	0	1	1	0	0	0	1	8	48
5:15 PM	0	0	0	0	0	0	2	0	0	1	1	0	0	0	0	0	4	35
5:30 PM	0	0	3	0	0	0	1	0	0	0	1	0	0	0	0	0	5	25
5:45 PM	0	0	1	0	0	0	0	0	0	0	0	0	0	1	0	1	3	20
Count Total	0	0	33	0	0	1	19	1	0	1	7	5	0	4	1	3	75	0
Peak Hour	0	0	8	0	0	0	11	0	0	1	3	1	0	0	0	1	25	0

Two-Hour Count Summaries - Bikes																		
Interval Start	N 130th St			N 130th St			1st Ave NE			1st Ave NE			15-min Total	Rolling One Hour				
	Eastbound			Westbound			Northbound			Southbound								
	LT	TH	RT	LT	TH	RT	LT	TH	RT	LT	TH	RT						
4:00 PM	0	0	0	0	0	0	0	0	0	0	0	0	0	0	0	0	0	0
4:15 PM	0	1	0	0	0	0	0	0	0	0	0	1	0	0	0	2	0	0
4:30 PM	0	0	0	0	0	1	0	0	0	1	0	0	0	0	0	2	0	0
4:45 PM	0	0	0	0	0	0	0	0	0	0	0	0	0	1	0	1	5	5
5:00 PM	0	1	0	0	0	0	0	0	0	0	0	0	0	0	0	1	6	6
5:15 PM	0	0	0	0	0	0	0	0	0	0	0	0	0	0	0	0	4	4
5:30 PM	0	0	0	0	0	0	0	0	0	1	0	0	0	0	0	1	3	3
5:45 PM	0	1	0	0	0	0	0	0	0	0	0	0	0	0	0	1	3	3
Count Total	0	3	0	0	0	1	0	0	0	2	0	1	1	1	0	8	0	0
Peak Hour	0	1	0	0	0	0	0	0	0	1	0	0	1	1	0	3	0	0

Note: U-Turn volumes for bikes are included in Left-Turn, if any.

Aurora Ave N N 115th St



Peak Hour

Date: 01/24/2023
Count Period: 7:00 AM to 9:00 AM
Peak Hour: 8:00 AM to 9:00 AM

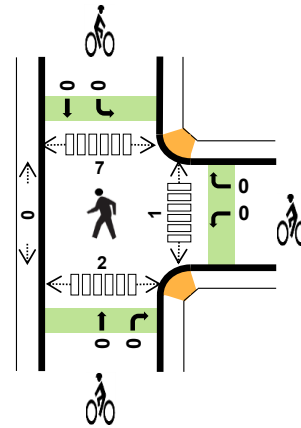
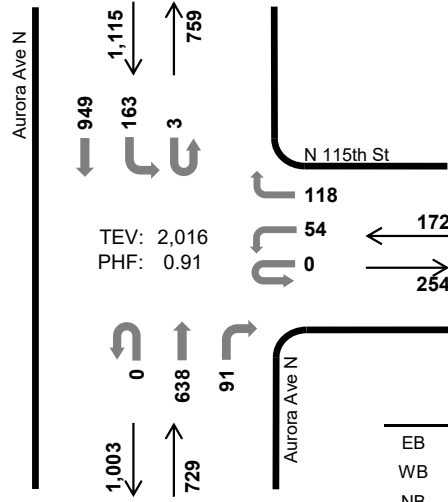

	HV %:	PHF
EB	-	-
WB	7.6%	0.91
NB	8.6%	0.84
SB	6.5%	0.89
TOTAL	7.3%	0.91

Two-Hour Count Summaries

Interval Start	0			N 115th St			Aurora Ave N			Aurora Ave N			15-min Total	Rolling One Hour					
	Eastbound			Westbound			Northbound			Southbound									
	UT	LT	TH	RT	UT	LT	TH	RT	UT	LT	TH	RT	UT	LT	TH	RT			
7:00 AM	0	0	0	0	0	5	0	16	0	0	59	12	0	25	156	0	273	0	
7:15 AM	0	0	0	0	0	3	0	16	0	0	96	12	0	52	190	0	369	0	
7:30 AM	0	0	0	0	0	17	0	31	0	0	106	13	0	37	216	0	420	0	
7:45 AM	0	0	0	0	0	14	0	19	0	0	127	31	0	39	237	0	467	1,529	
8:00 AM	0	0	0	0	0	9	0	31	0	0	146	18	0	33	217	0	454	1,710	
8:15 AM	0	0	0	0	0	17	0	23	0	0	161	25	0	38	225	0	489	1,830	
8:30 AM	0	0	0	0	0	17	0	30	0	0	143	19	2	53	257	0	521	1,931	
8:45 AM	0	0	0	0	0	11	0	34	0	0	188	29	1	39	250	0	552	2,016	
Count Total	0	0	0	0	0	93	0	200	0	0	1,026	159	3	316	1,748	0	3,545	0	
Peak Hour	All	0	0	0	0	0	54	0	118	0	0	638	91	3	163	949	0	2,016	0
	HV	0	0	0	0	0	6	0	7	0	0	57	6	0	2	70	0	148	0
	HV%	-	-	-	-	-	11%	-	6%	-	-	9%	7%	0%	1%	7%	-	7%	0

Note: Two-hour count summary volumes include heavy vehicles but exclude bicycles in overall count.

Interval Start	Heavy Vehicle Totals					Bicycles					Pedestrians (Crossing Leg)				
	EB	WB	NB	SB	Total	EB	WB	NB	SB	Total	East	West	North	South	Total
7:00 AM	0	1	6	9	16	0	0	0	0	0	0	0	3	0	3
7:15 AM	0	3	9	9	21	0	0	0	0	0	1	0	2	1	4
7:30 AM	0	0	11	14	25	0	0	1	0	1	0	0	2	0	2
7:45 AM	0	2	4	19	25	0	0	0	0	0	0	0	5	3	8
8:00 AM	0	4	15	20	39	0	0	0	0	0	1	0	1	0	2
8:15 AM	0	1	17	17	35	0	0	0	0	0	0	0	3	1	4
8:30 AM	0	5	13	25	43	0	0	0	0	0	0	0	1	0	1
8:45 AM	0	3	18	10	31	0	0	0	0	0	0	0	2	1	3
Count Total	0	19	93	123	235	0	0	1	0	1	2	0	19	6	27
Peak Hr	0	13	63	72	148	0	0	0	0	0	1	0	7	2	10

Two-Hour Count Summaries - Heavy Vehicles														15-min Total	Rolling One Hour			
Interval Start	0				N 115th St				Aurora Ave N				Aurora Ave N					
	Eastbound				Westbound				Northbound				Southbound					
	UT	LT	TH	RT	UT	LT	TH	RT	UT	LT	TH	RT	UT	LT	TH	RT		
7:00 AM	0	0	0	0	0	0	0	1	0	0	6	0	0	0	9	0		
7:15 AM	0	0	0	0	0	0	0	3	0	0	9	0	0	0	9	0		
7:30 AM	0	0	0	0	0	0	0	0	0	0	11	0	0	1	13	0		
7:45 AM	0	0	0	0	0	0	0	2	0	0	4	0	0	1	18	0		
8:00 AM	0	0	0	0	0	1	0	3	0	0	15	0	0	0	20	0		
8:15 AM	0	0	0	0	0	1	0	0	0	0	12	5	0	0	17	0		
8:30 AM	0	0	0	0	0	3	0	2	0	0	12	1	0	2	23	0		
8:45 AM	0	0	0	0	0	1	0	2	0	0	18	0	0	0	10	0		
Count Total	0	0	0	0	0	6	0	13	0	0	87	6	0	4	119	0		
Peak Hour	0	0	0	0	0	6	0	7	0	0	57	6	0	2	70	0		

Two-Hour Count Summaries - Bikes														15-min Total	Rolling One Hour
Interval Start	0			N 115th St			Aurora Ave N			Aurora Ave N					
	Eastbound			Westbound			Northbound			Southbound					
	LT	TH	RT	LT	TH	RT	LT	TH	RT	LT	TH	RT			
7:00 AM	0	0	0	0	0	0	0	0	0	0	0	0			
7:15 AM	0	0	0	0	0	0	0	0	0	0	0	0			
7:30 AM	0	0	0	0	0	0	0	0	1	0	0	0			
7:45 AM	0	0	0	0	0	0	0	0	0	0	0	0			
8:00 AM	0	0	0	0	0	0	0	0	0	0	0	0			
8:15 AM	0	0	0	0	0	0	0	0	0	0	0	0			
8:30 AM	0	0	0	0	0	0	0	0	0	0	0	0			
8:45 AM	0	0	0	0	0	0	0	0	0	0	0	0			
Count Total	0	0	0	0	0	0	0	0	1	0	0	0			
Peak Hour	0	0	0	0	0	0	0	0	0	0	0	0			

Note: U-Turn volumes for bikes are included in Left-Turn, if any.

Aurora Ave N N 115th St



Peak Hour

Date: 01/24/2023
Count Period: 4:00 PM to 6:00 PM
Peak Hour: 4:30 PM to 5:30 PM

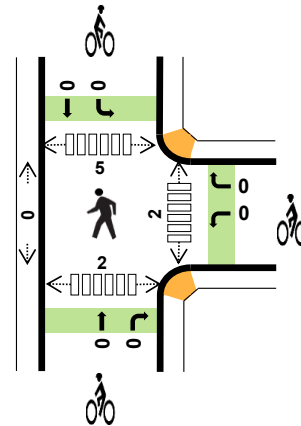
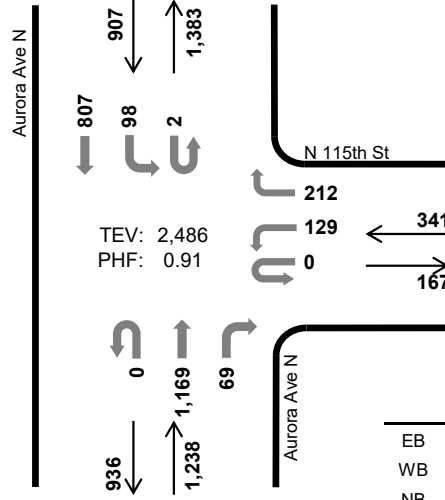

	HV %:	PHF
EB	-	-
WB	0.6%	0.86
NB	2.7%	0.86
SB	3.6%	0.94
TOTAL	2.7%	0.91

Two-Hour Count Summaries

Interval Start	0				N 115th St				Aurora Ave N				Aurora Ave N				15-min Total	Rolling One Hour	
	Eastbound				Westbound				Northbound				Southbound						
	UT	LT	TH	RT	UT	LT	TH	RT	UT	LT	TH	RT	UT	LT	TH	RT			
4:00 PM	0	0	0	0	0	20	0	56	0	0	242	17	0	13	242	0	590	0	
4:15 PM	0	0	0	0	0	25	0	52	0	0	271	22	0	19	214	0	603	0	
4:30 PM	0	0	0	0	0	33	0	66	0	0	262	13	1	21	183	0	579	0	
4:45 PM	0	0	0	0	0	22	0	53	0	0	246	12	0	28	213	0	574	2,346	
5:00 PM	0	0	0	0	0	38	0	48	0	0	335	25	0	35	205	0	686	2,442	
5:15 PM	0	0	0	0	0	36	0	45	0	0	326	19	1	14	206	0	647	2,486	
5:30 PM	0	0	0	0	0	20	0	47	0	0	266	17	0	20	179	0	549	2,456	
5:45 PM	0	0	0	0	1	21	0	44	0	0	250	15	1	20	187	0	539	2,421	
Count Total	0	0	0	0	1	215	0	411	0	0	2,198	140	3	170	1,629	0	4,767	0	
Peak Hour	All	0	0	0	0	0	129	0	212	0	0	1,169	69	2	98	807	0	2,486	0
	HV	0	0	0	0	0	1	0	1	0	0	33	0	0	2	31	0	68	0
	HV%	-	-	-	-	-	1%	-	0%	-	-	3%	0%	0%	2%	4%	-	3%	0

Note: Two-hour count summary volumes include heavy vehicles but exclude bicycles in overall count.

Interval Start	Heavy Vehicle Totals					Bicycles					Pedestrians (Crossing Leg)				
	EB	WB	NB	SB	Total	EB	WB	NB	SB	Total	East	West	North	South	Total
4:00 PM	0	2	17	10	29	0	0	0	0	0	0	0	6	2	8
4:15 PM	0	1	12	9	22	0	0	0	0	0	2	0	2	1	5
4:30 PM	0	0	15	7	22	0	0	0	0	0	1	0	2	2	5
4:45 PM	0	1	4	6	11	0	0	0	0	0	1	0	1	0	2
5:00 PM	0	0	9	12	21	0	0	0	0	0	0	0	1	0	1
5:15 PM	0	1	5	8	14	0	0	0	0	0	0	0	1	0	1
5:30 PM	0	1	6	2	9	0	0	0	0	0	0	0	0	2	2
5:45 PM	0	3	3	5	11	0	0	0	0	0	1	0	2	0	3
Count Total	0	9	71	59	139	0	0	0	0	0	5	0	15	7	27
Peak Hr	0	2	33	33	68	0	0	0	0	0	2	0	5	2	9

Two-Hour Count Summaries - Heavy Vehicles																		
Interval Start	0				N 115th St				Aurora Ave N				Aurora Ave N				15-min Total	Rolling One Hour
	Eastbound				Westbound				Northbound				Southbound					
	UT	LT	TH	RT	UT	LT	TH	RT	UT	LT	TH	RT	UT	LT	TH	RT		
4:00 PM	0	0	0	0	0	0	0	2	0	0	17	0	0	1	9	0	29	0
4:15 PM	0	0	0	0	0	0	0	1	0	0	11	1	0	0	9	0	22	0
4:30 PM	0	0	0	0	0	0	0	0	0	0	15	0	0	1	6	0	22	0
4:45 PM	0	0	0	0	0	0	0	1	0	0	4	0	0	0	6	0	11	84
5:00 PM	0	0	0	0	0	0	0	0	0	0	9	0	0	1	11	0	21	76
5:15 PM	0	0	0	0	0	1	0	0	0	0	5	0	0	0	8	0	14	68
5:30 PM	0	0	0	0	0	0	0	1	0	0	6	0	0	0	2	0	9	55
5:45 PM	0	0	0	0	0	0	0	3	0	0	3	0	0	0	5	0	11	55
Count Total	0	0	0	0	0	1	0	8	0	0	70	1	0	3	56	0	139	0
Peak Hour	0	0	0	0	0	1	0	1	0	0	33	0	0	2	31	0	68	0

Two-Hour Count Summaries - Bikes														
Interval Start	0			N 115th St			Aurora Ave N			Aurora Ave N			15-min Total	Rolling One Hour
	Eastbound			Westbound			Northbound			Southbound				
	LT	TH	RT	LT	TH	RT	LT	TH	RT	LT	TH	RT		
4:00 PM	0	0	0	0	0	0	0	0	0	0	0	0	0	0
4:15 PM	0	0	0	0	0	0	0	0	0	0	0	0	0	0
4:30 PM	0	0	0	0	0	0	0	0	0	0	0	0	0	0
4:45 PM	0	0	0	0	0	0	0	0	0	0	0	0	0	0
5:00 PM	0	0	0	0	0	0	0	0	0	0	0	0	0	0
5:15 PM	0	0	0	0	0	0	0	0	0	0	0	0	0	0
5:30 PM	0	0	0	0	0	0	0	0	0	0	0	0	0	0
5:45 PM	0	0	0	0	0	0	0	0	0	0	0	0	0	0
Count Total	0	0	0	0	0	0	0	0	0	0	0	0	0	0
Peak Hour	0	0	0	0	0	0	0	0	0	0	0	0	0	0

Note: U-Turn volumes for bikes are included in Left-Turn, if any.

Meridian Ave N N 115th St



Peak Hour

Date: 01/24/2023
Count Period: 7:00 AM to 9:00 AM
Peak Hour: 7:30 AM to 8:30 AM

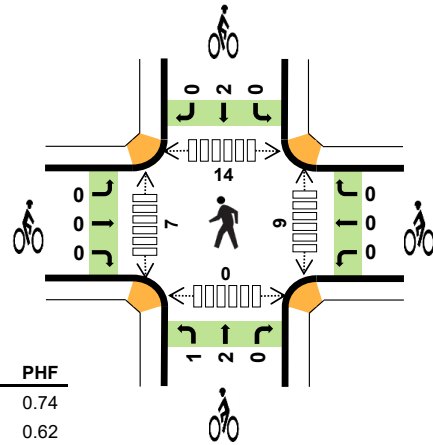
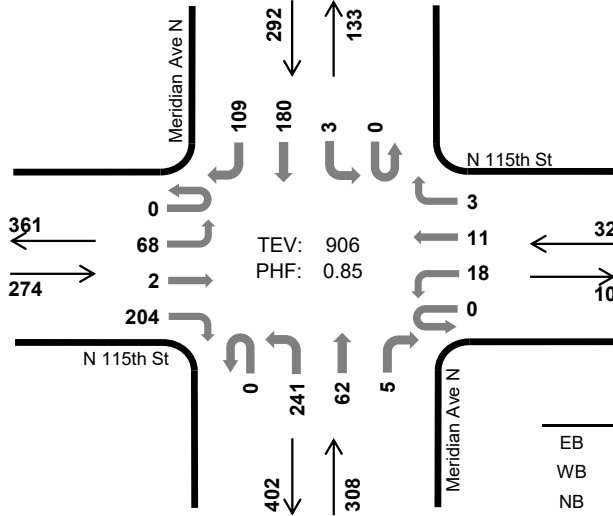

	HV %:	PHF
EB	5.1%	0.74
WB	9.4%	0.62
NB	5.8%	0.90
SB	3.8%	0.87
TOTAL	5.1%	0.85

Two-Hour Count Summaries

Interval Start	N 115th St Eastbound				N 115th St Westbound				Meridian Ave N Northbound				Meridian Ave N Southbound				15-min Total	Rolling One Hour	
	UT	LT	TH	RT	UT	LT	TH	RT	UT	LT	TH	RT	UT	LT	TH	RT			
7:00 AM	0	7	0	25	0	1	2	0	0	55	12	0	0	1	26	15	144	0	
7:15 AM	0	5	1	52	0	1	2	0	0	64	8	0	0	1	35	17	186	0	
7:30 AM	0	23	0	69	0	5	2	1	0	55	12	2	0	2	39	22	232	0	
7:45 AM	0	25	2	55	0	6	6	1	0	66	18	2	0	0	43	41	265	827	
8:00 AM	0	14	0	43	0	5	2	1	0	60	14	1	0	0	49	28	217	900	
8:15 AM	0	6	0	37	0	2	1	0	0	60	18	0	0	1	49	18	192	906	
8:30 AM	0	6	1	40	0	2	3	1	0	60	27	0	0	1	27	24	192	866	
8:45 AM	0	11	4	53	0	2	3	1	0	61	27	6	0	1	62	35	266	867	
Count Total	0	97	8	374	0	24	21	5	0	481	136	11	0	7	330	200	1,694	0	
Peak Hour	All	0	68	2	204	0	18	11	3	0	241	62	5	0	3	180	109	906	0
	HV	0	7	0	7	0	2	0	1	0	13	5	0	0	1	4	6	46	0
	HV%	-	10%	0%	3%	-	11%	0%	33%	-	5%	8%	0%	-	33%	2%	6%	5%	0

Note: Two-hour count summary volumes include heavy vehicles but exclude bicycles in overall count.

Interval Start	Heavy Vehicle Totals					Bicycles					Pedestrians (Crossing Leg)				
	EB	WB	NB	SB	Total	EB	WB	NB	SB	Total	East	West	North	South	Total
7:00 AM	2	0	4	4	10	0	0	1	0	1	2	3	2	0	7
7:15 AM	2	1	2	1	6	0	0	1	1	2	2	0	2	0	4
7:30 AM	3	1	1	5	10	0	0	1	2	3	2	3	4	0	9
7:45 AM	3	0	5	1	9	0	0	1	0	1	2	1	7	0	10
8:00 AM	2	1	6	2	11	0	0	0	0	0	1	1	1	0	3
8:15 AM	6	1	6	3	16	0	0	1	0	1	4	2	2	0	8
8:30 AM	4	0	2	3	9	0	1	0	3	4	5	0	4	0	9
8:45 AM	4	0	6	3	13	0	1	0	0	1	4	1	2	0	7
Count Total	26	4	32	22	84	0	2	5	6	13	22	11	24	0	57
Peak Hour	14	3	18	11	46	0	0	3	2	5	9	7	14	0	30

Two-Hour Count Summaries - Heavy Vehicles																		
Interval Start	N 115th St				N 115th St				Meridian Ave N				Meridian Ave N				15-min Total	Rolling One Hour
	Eastbound				Westbound				Northbound				Southbound					
	UT	LT	TH	RT	UT	LT	TH	RT	UT	LT	TH	RT	UT	LT	TH	RT		
7:00 AM	0	1	0	1	0	0	0	0	0	3	1	0	0	0	2	2	10	0
7:15 AM	0	1	0	1	0	0	1	0	0	2	0	0	0	0	1	0	6	0
7:30 AM	0	0	0	3	0	1	0	0	0	1	0	0	0	1	1	3	10	0
7:45 AM	0	1	0	2	0	0	0	0	0	3	2	0	0	0	0	1	9	35
8:00 AM	0	1	0	1	0	0	0	1	0	5	1	0	0	0	1	1	11	36
8:15 AM	0	5	0	1	0	1	0	0	0	4	2	0	0	0	2	1	16	46
8:30 AM	0	0	0	4	0	0	0	0	0	2	0	0	0	0	0	3	9	45
8:45 AM	0	2	0	2	0	0	0	0	0	3	3	0	0	0	2	1	13	49
Count Total	0	11	0	15	0	2	1	1	0	23	9	0	0	1	9	12	84	0
Peak Hour	0	7	0	7	0	2	0	1	0	13	5	0	0	1	4	6	46	0

Two-Hour Count Summaries - Bikes																	
Interval Start	N 115th St			N 115th St			Meridian Ave N			Meridian Ave N			15-min Total	Rolling One Hour			
	Eastbound			Westbound			Northbound			Southbound							
	LT	TH	RT	LT	TH	RT	LT	TH	RT	LT	TH	RT					
7:00 AM	0	0	0	0	0	0	0	0	1	0	0	0	0	0	0	1	0
7:15 AM	0	0	0	0	0	0	0	0	1	0	0	0	1	0	0	2	0
7:30 AM	0	0	0	0	0	0	0	1	0	0	0	2	0	0	0	3	0
7:45 AM	0	0	0	0	0	0	0	0	1	0	0	0	0	0	0	1	7
8:00 AM	0	0	0	0	0	0	0	0	0	0	0	0	0	0	0	0	6
8:15 AM	0	0	0	0	0	0	0	0	1	0	0	0	0	0	0	1	5
8:30 AM	0	0	0	0	0	1	0	0	0	0	0	0	3	0	0	4	6
8:45 AM	0	0	0	0	0	1	0	0	0	0	0	0	0	0	0	1	6
Count Total	0	0	0	0	0	2	0	1	4	0	0	6	0	0	0	13	0
Peak Hour	0	0	0	0	0	0	0	1	2	0	0	2	0	0	0	5	0

Note: U-Turn volumes for bikes are included in Left-Turn, if any.

Meridian Ave N N 115th St



Peak Hour

Date: 01/24/2023
Count Period: 4:00 PM to 6:00 PM
Peak Hour: 4:15 PM to 5:15 PM

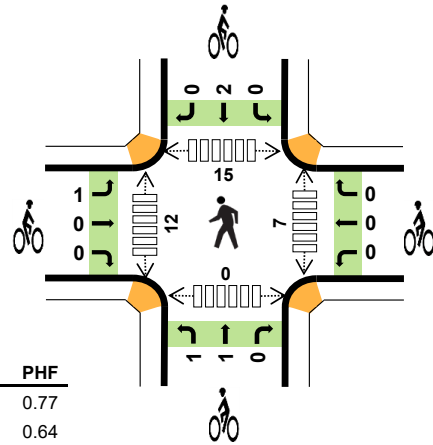
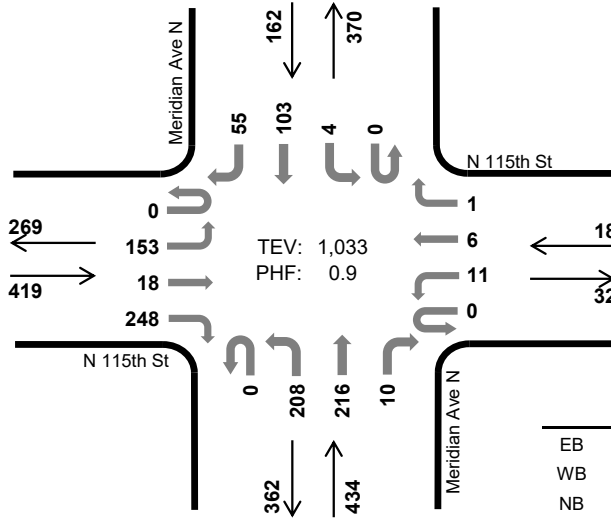

	HV %:	PHF
EB	2.1%	0.77
WB	5.6%	0.64
NB	3.0%	0.94
SB	4.9%	0.86
TOTAL	3.0%	0.90

Two-Hour Count Summaries

Interval Start	N 115th St Eastbound				N 115th St Westbound				Meridian Ave N Northbound				Meridian Ave N Southbound				15-min Total	Rolling One Hour	
	UT	LT	TH	RT	UT	LT	TH	RT	UT	LT	TH	RT	UT	LT	TH	RT			
4:00 PM	0	30	0	55	0	3	0	1	0	46	45	6	0	0	27	18	231	0	
4:15 PM	0	29	4	49	0	2	1	0	0	57	57	1	0	2	27	13	242	0	
4:30 PM	0	46	7	75	0	5	1	1	0	54	50	0	0	0	25	9	273	0	
4:45 PM	0	33	4	36	0	3	4	0	0	54	50	7	0	1	24	14	230	976	
5:00 PM	0	45	3	88	0	1	0	0	0	43	59	2	0	1	27	19	288	1,033	
5:15 PM	0	31	4	54	0	2	5	2	0	48	45	3	0	0	23	18	235	1,026	
5:30 PM	0	33	1	43	0	3	5	0	0	50	58	7	0	0	26	12	238	991	
5:45 PM	0	29	4	38	0	1	2	0	0	43	48	0	0	0	30	8	203	964	
Count Total	0	276	27	438	0	20	18	4	0	395	412	26	0	4	209	111	1,940	0	
Peak Hour	All	0	153	18	248	0	11	6	1	0	208	216	10	0	4	103	55	1,033	0
	HV	0	3	1	5	0	1	0	0	0	6	7	0	0	0	6	2	31	0
	HV%	-	2%	6%	2%	-	9%	0%	0%	-	3%	3%	0%	-	0%	6%	4%	3%	0

Note: Two-hour count summary volumes include heavy vehicles but exclude bicycles in overall count.

Interval Start	Heavy Vehicle Totals					Bicycles					Pedestrians (Crossing Leg)				
	EB	WB	NB	SB	Total	EB	WB	NB	SB	Total	East	West	North	South	Total
4:00 PM	4	1	2	4	11	0	0	1	1	2	4	2	2	0	8
4:15 PM	1	1	5	2	9	0	0	0	1	1	3	1	7	0	11
4:30 PM	3	0	2	2	7	1	0	0	0	1	1	3	2	0	6
4:45 PM	2	0	3	2	7	0	0	0	1	1	3	5	5	0	13
5:00 PM	3	0	3	2	8	0	0	2	0	2	0	3	1	0	4
5:15 PM	0	0	1	2	3	1	0	0	0	1	2	2	3	0	7
5:30 PM	3	0	4	1	8	0	0	1	0	1	3	0	1	0	4
5:45 PM	2	0	7	2	11	0	0	1	0	1	1	0	0	0	1
Count Total	18	2	27	17	64	2	0	5	3	10	17	16	21	0	54
Peak Hour	9	1	13	8	31	1	0	2	2	5	7	12	15	0	34

Two-Hour Count Summaries - Heavy Vehicles																			
Interval Start	N 115th St				N 115th St				Meridian Ave N				Meridian Ave N				15-min Total	Rolling One Hour	
	Eastbound				Westbound				Northbound				Southbound						
	UT	LT	TH	RT	UT	LT	TH	RT	UT	LT	TH	RT	UT	LT	TH	RT			
4:00 PM	0	1	0	3	0	1	0	0	0	2	0	0	0	0	0	1	3	11	0
4:15 PM	0	0	1	0	0	1	0	0	0	0	2	3	0	0	0	1	1	9	0
4:30 PM	0	1	0	2	0	0	0	0	0	0	1	1	0	0	0	2	0	7	0
4:45 PM	0	1	0	1	0	0	0	0	0	0	2	1	0	0	0	2	0	7	34
5:00 PM	0	1	0	2	0	0	0	0	0	0	1	2	0	0	0	1	1	8	31
5:15 PM	0	0	0	0	0	0	0	0	0	0	1	0	0	0	0	1	1	3	25
5:30 PM	0	1	0	2	0	0	0	0	0	0	3	1	0	0	0	1	0	8	26
5:45 PM	0	2	0	0	0	0	0	0	0	0	6	1	0	0	0	1	1	11	30
Count Total	0	7	1	10	0	2	0	0	0	0	18	9	0	0	0	10	7	64	0
Peak Hour	0	3	1	5	0	1	0	0	0	0	6	7	0	0	0	6	2	31	0

Two-Hour Count Summaries - Bikes																	
Interval Start	N 115th St			N 115th St			Meridian Ave N			Meridian Ave N			15-min Total	Rolling One Hour			
	Eastbound			Westbound			Northbound			Southbound							
	LT	TH	RT	LT	TH	RT	LT	TH	RT	LT	TH	RT					
4:00 PM	0	0	0	0	0	0	0	0	1	0	0	1	0	2	0		
4:15 PM	0	0	0	0	0	0	0	0	0	0	0	1	0	1	0		
4:30 PM	1	0	0	0	0	0	0	0	0	0	0	0	0	1	0		
4:45 PM	0	0	0	0	0	0	0	0	0	0	0	1	0	1	5		
5:00 PM	0	0	0	0	0	0	0	1	1	0	0	0	0	2	5		
5:15 PM	1	0	0	0	0	0	0	0	0	0	0	0	0	1	5		
5:30 PM	0	0	0	0	0	0	0	0	1	0	0	0	0	1	5		
5:45 PM	0	0	0	0	0	0	0	0	1	0	0	0	0	1	5		
Count Total	2	0	0	0	0	0	0	1	4	0	0	3	0	10	0		
Peak Hour	1	0	0	0	0	0	0	1	1	0	0	2	0	5	0		

Note: U-Turn volumes for bikes are included in Left-Turn, if any.

Aurora Ave N N Northgate Way



Peak Hour

Date: 01/24/2023
Count Period: 7:00 AM to 9:00 AM
Peak Hour: 8:00 AM to 9:00 AM

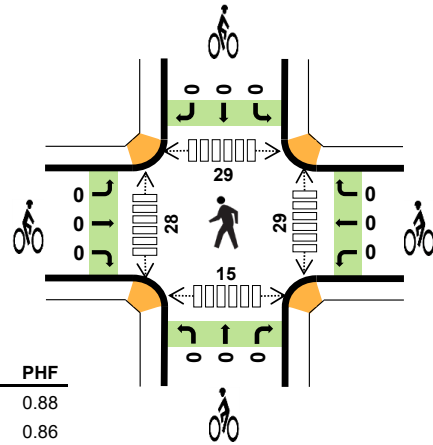
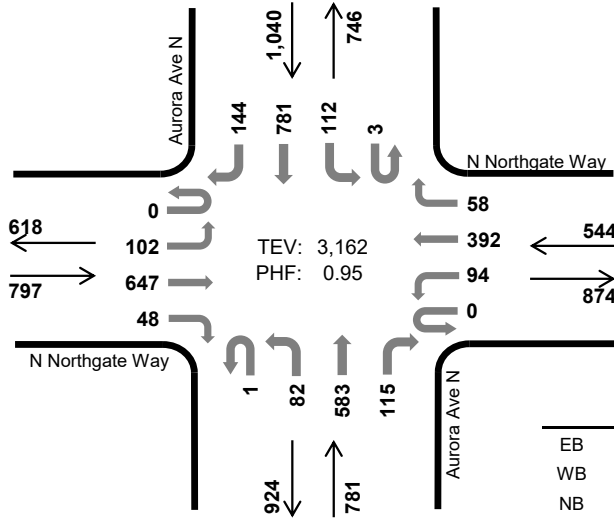

	HV %:	PHF
EB	4.6%	0.88
WB	5.7%	0.86
NB	7.4%	0.96
SB	8.4%	0.91
TOTAL	6.7%	0.95

Two-Hour Count Summaries

Interval Start	N Northgate Way				N Northgate Way				Aurora Ave N				Aurora Ave N				15-min Total	Rolling One Hour	
	Eastbound		Westbound		Northbound		Southbound		UT	LT	TH	RT	UT	LT	TH	RT			
7:00 AM	0	15	137	9	0	17	77	1	0	8	62	21	0	23	132	18	520	0	
7:15 AM	0	17	147	8	0	18	103	12	0	6	72	29	0	13	165	24	614	0	
7:30 AM	0	18	162	12	0	18	93	6	0	13	94	30	0	31	197	29	703	0	
7:45 AM	0	29	195	4	0	27	111	11	0	24	123	35	0	35	179	26	799	2,636	
8:00 AM	0	20	150	11	0	17	106	18	0	23	144	31	1	27	176	30	754	2,870	
8:15 AM	0	22	172	10	0	27	114	17	0	15	144	31	1	31	184	37	805	3,061	
8:30 AM	0	21	157	8	0	27	89	8	0	20	141	28	0	22	214	32	767	3,125	
8:45 AM	0	39	168	19	0	23	83	15	1	24	154	25	1	32	207	45	836	3,162	
Count Total	0	181	1,288	81	0	174	776	88	1	133	934	230	3	214	1,454	241	5,798	0	
Peak Hour	All	0	102	647	48	0	94	392	58	1	82	583	115	3	112	781	144	3,162	0
	HV	0	7	27	3	0	4	22	5	0	4	49	5	0	10	68	9	213	0
	HV%	-	7%	4%	6%	-	4%	6%	9%	0%	5%	8%	4%	0%	9%	9%	6%	7%	0

Note: Two-hour count summary volumes include heavy vehicles but exclude bicycles in overall count.

Interval Start	Heavy Vehicle Totals					Bicycles					Pedestrians (Crossing Leg)				
	EB	WB	NB	SB	Total	EB	WB	NB	SB	Total	East	West	North	South	Total
7:00 AM	3	8	5	6	22	0	0	0	0	0	3	3	2	0	8
7:15 AM	2	7	7	12	28	0	0	0	0	0	5	0	0	0	5
7:30 AM	7	8	11	10	36	0	0	1	0	1	9	3	2	4	18
7:45 AM	6	12	6	18	42	0	0	0	0	0	5	2	1	7	15
8:00 AM	6	9	15	26	56	0	0	0	0	0	7	6	5	1	19
8:15 AM	10	7	15	21	53	0	0	0	0	0	10	9	8	8	35
8:30 AM	13	8	12	27	60	0	0	0	0	0	8	5	6	5	24
8:45 AM	8	7	16	13	44	0	0	0	0	0	4	8	10	1	23
Count Total	55	66	87	133	341	0	0	1	0	1	51	36	34	26	147
Peak Hour	37	31	58	87	213	0	0	0	0	0	29	28	29	15	101

Two-Hour Count Summaries - Heavy Vehicles																		
Interval Start	N Northgate Way				N Northgate Way				Aurora Ave N				Aurora Ave N				15-min Total	Rolling One Hour
	Eastbound				Westbound				Northbound				Southbound					
	UT	LT	TH	RT	UT	LT	TH	RT	UT	LT	TH	RT	UT	LT	TH	RT		
7:00 AM	0	0	3	0	0	2	6	0	0	1	4	0	0	0	5	1	22	0
7:15 AM	0	0	2	0	0	1	4	2	0	1	6	0	0	0	9	3	28	0
7:30 AM	0	1	5	1	0	1	6	1	0	1	8	2	0	1	8	1	36	0
7:45 AM	0	1	5	0	0	2	9	1	0	0	4	2	0	1	15	2	42	128
8:00 AM	0	0	5	1	0	0	6	3	0	1	13	1	0	2	23	1	56	162
8:15 AM	0	1	7	2	0	2	5	0	0	1	12	2	0	2	16	3	53	187
8:30 AM	0	5	8	0	0	2	6	0	0	0	10	2	0	3	21	3	60	211
8:45 AM	0	1	7	0	0	0	5	2	0	2	14	0	0	3	8	2	44	213
Count Total	0	9	42	4	0	10	47	9	0	7	71	9	0	12	105	16	341	0
Peak Hour	0	7	27	3	0	4	22	5	0	4	49	5	0	10	68	9	213	0

Two-Hour Count Summaries - Bikes																	
Interval Start	N Northgate Way			N Northgate Way			Aurora Ave N			Aurora Ave N			15-min Total	Rolling One Hour			
	Eastbound			Westbound			Northbound			Southbound							
	LT	TH	RT	LT	TH	RT	LT	TH	RT	LT	TH	RT					
7:00 AM	0	0	0	0	0	0	0	0	0	0	0	0	0	0	0	0	0
7:15 AM	0	0	0	0	0	0	0	0	0	0	0	0	0	0	0	0	0
7:30 AM	0	0	0	0	0	0	0	0	0	1	0	0	0	0	0	0	1
7:45 AM	0	0	0	0	0	0	0	0	0	0	0	0	0	0	0	0	0
8:00 AM	0	0	0	0	0	0	0	0	0	0	0	0	0	0	0	0	1
8:15 AM	0	0	0	0	0	0	0	0	0	0	0	0	0	0	0	0	1
8:30 AM	0	0	0	0	0	0	0	0	0	0	0	0	0	0	0	0	0
8:45 AM	0	0	0	0	0	0	0	0	0	0	0	0	0	0	0	0	0
Count Total	0	0	0	0	0	0	0	0	0	1	0	0	0	0	0	0	1
Peak Hour	0	0	0	0	0	0	0	0	0	0	0	0	0	0	0	0	0

Note: U-Turn volumes for bikes are included in Left-Turn, if any.

Aurora Ave N N Northgate Way



Peak Hour

Date: 01/24/2023
Count Period: 4:00 PM to 6:00 PM
Peak Hour: 5:00 PM to 6:00 PM

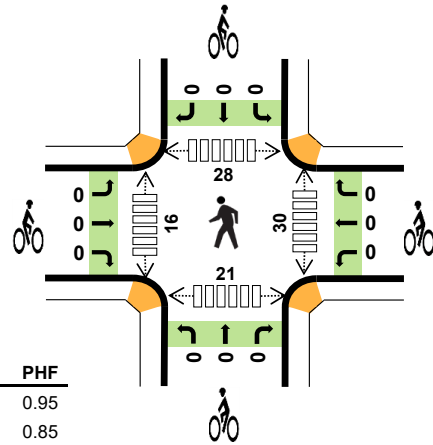
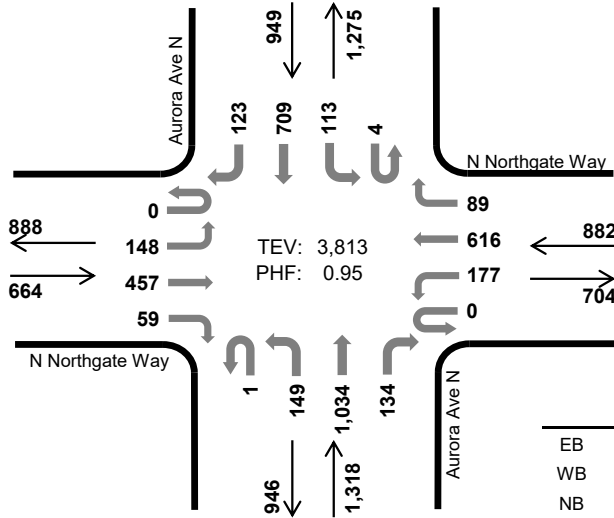

	HV %:	PHF
EB	1.4%	0.95
WB	0.9%	0.85
NB	2.0%	0.89
SB	2.8%	0.86
TOTAL	1.9%	0.95

Two-Hour Count Summaries

Interval Start	N Northgate Way				N Northgate Way				Aurora Ave N				Aurora Ave N				15-min Total	Rolling One Hour	
	Eastbound		Westbound		Northbound		Southbound		UT	LT	TH	RT	UT	LT	TH	RT			
4:00 PM	0	39	108	9	0	36	169	11	1	22	210	22	0	26	201	37	891	0	
4:15 PM	0	35	126	8	0	39	145	24	0	39	261	36	3	25	183	49	973	0	
4:30 PM	0	30	100	12	0	42	157	15	1	30	262	38	2	29	177	31	926	0	
4:45 PM	0	28	117	17	0	39	155	23	1	37	216	23	0	22	163	30	871	3,661	
5:00 PM	0	36	110	11	0	40	139	21	1	35	305	30	1	27	208	39	1,003	3,773	
5:15 PM	0	39	113	23	0	48	191	19	0	34	247	39	0	18	166	30	967	3,767	
5:30 PM	0	35	111	18	0	35	149	26	0	42	243	38	3	35	174	28	937	3,778	
5:45 PM	0	38	123	7	0	54	137	23	0	38	239	27	0	33	161	26	906	3,813	
Count Total	0	280	908	105	0	333	1,242	162	4	277	1,983	253	9	215	1,433	270	7,474	0	
Peak Hour	All	0	148	457	59	0	177	616	89	1	149	1,034	134	4	113	709	123	3,813	0
	HV	0	1	6	2	0	0	8	0	0	1	23	3	0	2	24	1	71	0
	HV%	-	1%	1%	3%	-	0%	1%	0%	0%	1%	2%	2%	0%	2%	3%	1%	2%	0

Note: Two-hour count summary volumes include heavy vehicles but exclude bicycles in overall count.

Interval Start	Heavy Vehicle Totals					Bicycles					Pedestrians (Crossing Leg)				
	EB	WB	NB	SB	Total	EB	WB	NB	SB	Total	East	West	North	South	Total
4:00 PM	6	10	18	13	47	0	0	0	0	0	11	25	13	10	59
4:15 PM	7	6	15	6	34	0	0	0	0	0	13	12	10	6	41
4:30 PM	5	4	13	8	30	0	0	0	1	1	5	6	7	8	26
4:45 PM	5	5	3	5	18	0	0	0	1	1	10	11	10	9	40
5:00 PM	2	2	11	12	27	0	0	0	0	0	10	9	5	8	32
5:15 PM	3	1	4	8	16	0	0	0	0	0	2	3	8	1	14
5:30 PM	1	2	6	3	12	0	0	0	0	0	9	3	6	3	21
5:45 PM	3	3	6	4	16	0	0	0	0	0	9	1	9	9	28
Count Total	32	33	76	59	200	0	0	0	2	2	69	70	68	54	261
Peak Hour	9	8	27	27	71	0	0	0	0	0	30	16	28	21	95

Two-Hour Count Summaries - Heavy Vehicles																		
Interval Start	N Northgate Way				N Northgate Way				Aurora Ave N				Aurora Ave N				15-min Total	Rolling One Hour
	Eastbound				Westbound				Northbound				Southbound					
	UT	LT	TH	RT	UT	LT	TH	RT	UT	LT	TH	RT	UT	LT	TH	RT		
4:00 PM	0	2	4	0	0	2	6	2	0	1	16	1	0	1	10	2	47	0
4:15 PM	0	1	6	0	0	0	5	1	0	0	14	1	0	0	4	2	34	0
4:30 PM	0	2	2	1	0	1	3	0	0	0	11	2	0	0	8	0	30	0
4:45 PM	0	0	4	1	0	1	4	0	0	0	3	0	0	0	4	1	18	129
5:00 PM	0	0	2	0	0	0	2	0	0	0	11	0	0	1	11	0	27	109
5:15 PM	0	1	1	1	0	0	1	0	0	0	4	0	0	0	8	0	16	91
5:30 PM	0	0	1	0	0	0	2	0	0	0	6	0	0	1	1	1	12	73
5:45 PM	0	0	2	1	0	0	3	0	0	1	2	3	0	0	4	0	16	71
Count Total	0	6	22	4	0	4	26	3	0	2	67	7	0	3	50	6	200	0
Peak Hour	0	1	6	2	0	0	8	0	0	1	23	3	0	2	24	1	71	0

Two-Hour Count Summaries - Bikes																		
Interval Start	N Northgate Way			N Northgate Way			Aurora Ave N			Aurora Ave N			15-min Total	Rolling One Hour				
	Eastbound			Westbound			Northbound			Southbound								
	LT	TH	RT	LT	TH	RT	LT	TH	RT	LT	TH	RT						
4:00 PM	0	0	0	0	0	0	0	0	0	0	0	0	0	0	0	0	0	0
4:15 PM	0	0	0	0	0	0	0	0	0	0	0	0	0	0	0	0	0	0
4:30 PM	0	0	0	0	0	0	0	0	0	0	0	0	0	1	0	0	1	0
4:45 PM	0	0	0	0	0	0	0	0	0	0	0	0	0	1	0	0	1	2
5:00 PM	0	0	0	0	0	0	0	0	0	0	0	0	0	0	0	0	0	2
5:15 PM	0	0	0	0	0	0	0	0	0	0	0	0	0	0	0	0	0	2
5:30 PM	0	0	0	0	0	0	0	0	0	0	0	0	0	0	0	0	0	1
5:45 PM	0	0	0	0	0	0	0	0	0	0	0	0	0	0	0	0	0	0
Count Total	0	0	0	0	0	0	0	0	0	0	0	0	0	2	0	0	2	0
Peak Hour	0	0	0	0	0	0	0	0	0	0	0	0	0	0	0	0	0	0

Note: U-Turn volumes for bikes are included in Left-Turn, if any.

Meridian Ave N N Northgate Way



Peak Hour

Date: 01/24/2023
Count Period: 7:00 AM to 9:00 AM
Peak Hour: 7:30 AM to 8:30 AM

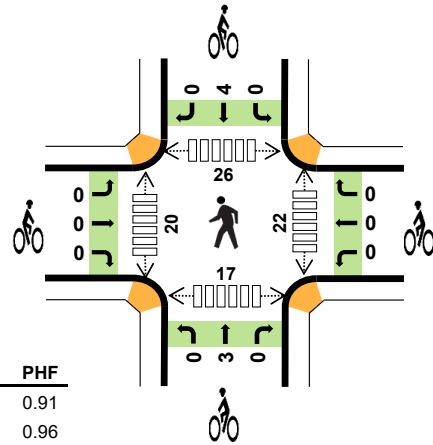
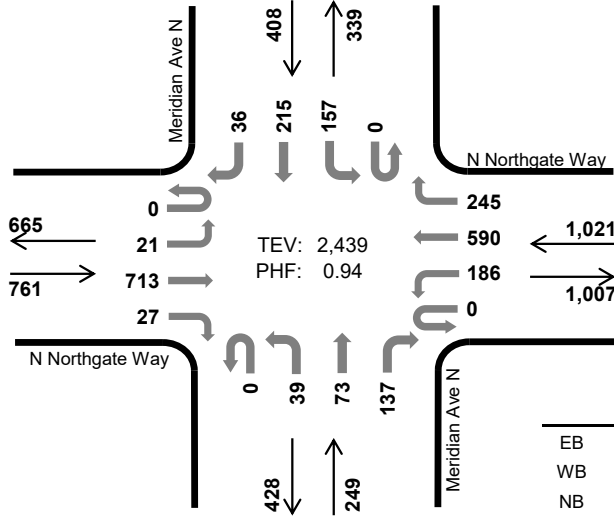

	HV %:	PHF
EB	4.2%	0.91
WB	4.4%	0.96
NB	7.2%	0.80
SB	4.4%	0.82
TOTAL	4.6%	0.94

Two-Hour Count Summaries

Interval Start	N Northgate Way				N Northgate Way				Meridian Ave N				Meridian Ave N				15-min Total	Rolling One Hour	
	Eastbound		Westbound		Northbound		Southbound		UT	LT	TH	RT	UT	LT	TH	RT			
7:00 AM	0	3	130	8	0	35	123	52	0	4	16	20	0	20	38	8	457	0	
7:15 AM	0	2	143	12	0	28	143	61	0	17	7	25	0	38	40	4	520	0	
7:30 AM	0	4	184	10	0	41	136	56	0	7	10	28	0	46	69	10	601	0	
7:45 AM	0	6	196	7	0	44	151	65	0	9	22	47	0	37	57	5	646	2,224	
8:00 AM	0	4	167	5	0	57	148	60	0	13	23	38	0	42	50	10	617	2,384	
8:15 AM	0	7	166	5	0	44	155	64	0	10	18	24	0	32	39	11	575	2,439	
8:30 AM	0	10	156	10	0	58	118	59	0	7	30	32	0	31	76	9	596	2,434	
8:45 AM	0	8	148	8	0	72	106	69	0	10	29	47	0	42	78	8	625	2,413	
Count Total	0	44	1,290	65	0	379	1,080	486	0	77	155	261	0	288	447	65	4,637	0	
Peak Hour	All	0	21	713	27	0	186	590	245	0	39	73	137	0	157	215	36	2,439	0
	HV	0	3	25	4	0	5	31	9	0	9	9	0	0	7	9	2	113	0
	HV%	-	14%	4%	15%	-	3%	5%	4%	-	23%	12%	0%	-	4%	4%	6%	5%	0

Note: Two-hour count summary include heavy vehicles but exclude bicycles in overall count.

Interval Start	Heavy Vehicle Totals					Bicycles					Pedestrians (Crossing Leg)				
	EB	WB	NB	SB	Total	EB	WB	NB	SB	Total	East	West	North	South	Total
7:00 AM	2	12	3	4	21	0	0	0	1	1	3	8	4	1	16
7:15 AM	3	6	5	2	16	0	0	1	1	2	5	5	3	2	15
7:30 AM	8	9	3	7	27	0	0	2	1	3	4	9	6	4	23
7:45 AM	9	13	4	3	29	0	0	0	0	0	3	1	9	5	18
8:00 AM	8	12	7	4	31	0	0	0	0	0	5	4	7	3	19
8:15 AM	7	11	4	4	26	0	0	1	3	4	10	6	4	5	25
8:30 AM	11	9	2	6	28	0	0	1	1	2	3	6	5	3	17
8:45 AM	9	6	8	3	26	0	0	0	0	0	5	7	5	5	22
Count Total	57	78	36	33	204	0	0	5	7	12	38	46	43	28	155
Peak Hour	32	45	18	18	113	0	0	3	4	7	22	20	26	17	85

Two-Hour Count Summaries - Heavy Vehicles																		
Interval Start	N Northgate Way				N Northgate Way				Meridian Ave N				Meridian Ave N				15-min Total	Rolling One Hour
	Eastbound				Westbound				Northbound				Southbound					
	UT	LT	TH	RT	UT	LT	TH	RT	UT	LT	TH	RT	UT	LT	TH	RT		
7:00 AM	0	0	1	1	0	2	8	2	0	2	1	0	0	0	3	1	21	0
7:15 AM	0	0	2	1	0	1	4	1	0	4	1	0	0	1	1	0	16	0
7:30 AM	0	0	6	2	0	3	6	0	0	2	1	0	0	2	4	1	27	0
7:45 AM	0	0	8	1	0	0	9	4	0	1	3	0	0	1	2	0	29	93
8:00 AM	0	2	5	1	0	1	8	3	0	4	3	0	0	2	2	0	31	103
8:15 AM	0	1	6	0	0	1	8	2	0	2	2	0	0	2	1	1	26	113
8:30 AM	0	0	7	4	0	1	6	2	0	1	1	0	0	2	4	0	28	114
8:45 AM	0	1	8	0	0	1	4	1	0	3	4	1	0	0	3	0	26	111
Count Total	0	4	43	10	0	10	53	15	0	19	16	1	0	10	20	3	204	0
Peak Hour	0	3	25	4	0	5	31	9	0	9	9	0	0	7	9	2	113	0

Two-Hour Count Summaries - Bikes																	
Interval Start	N Northgate Way			N Northgate Way			Meridian Ave N			Meridian Ave N			15-min Total	Rolling One Hour			
	Eastbound			Westbound			Northbound			Southbound							
	LT	TH	RT	LT	TH	RT	LT	TH	RT	LT	TH	RT					
7:00 AM	0	0	0	0	0	0	0	0	0	0	0	0	1	0	1	0	
7:15 AM	0	0	0	0	0	0	0	0	1	0	0	0	1	0	2	0	
7:30 AM	0	0	0	0	0	0	0	0	2	0	0	0	1	0	3	0	
7:45 AM	0	0	0	0	0	0	0	0	0	0	0	0	0	0	0	0	6
8:00 AM	0	0	0	0	0	0	0	0	0	0	0	0	0	0	0	0	5
8:15 AM	0	0	0	0	0	0	0	0	1	0	0	0	3	0	4	7	
8:30 AM	0	0	0	0	0	0	0	0	1	0	0	0	1	0	2	6	
8:45 AM	0	0	0	0	0	0	0	0	0	0	0	0	0	0	0	0	6
Count Total	0	0	0	0	0	0	0	0	5	0	0	0	7	0	12	0	
Peak Hour	0	0	0	0	0	0	0	0	3	0	0	0	4	0	7	0	

Note: U-Turn volumes for bikes are included in Left-Turn, if any.

Meridian Ave N N Northgate Way



Date: 01/24/2023
 Count Period: 4:00 PM to 6:00 PM
 Peak Hour: 4:30 PM to 5:30 PM

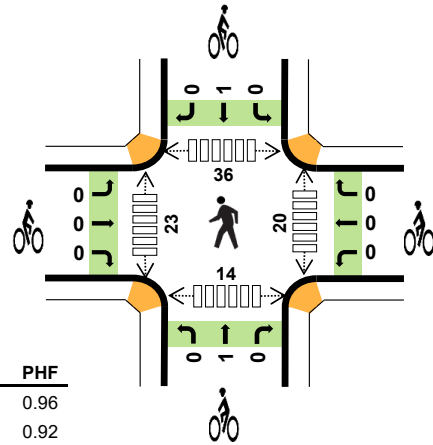
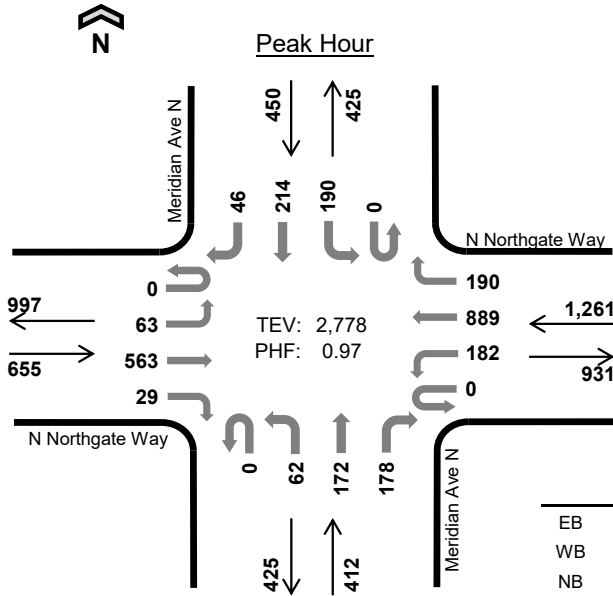

	HV %:	PHF
EB	3.1%	0.96
WB	1.0%	0.92
NB	3.2%	0.93
SB	2.0%	0.85
TOTAL	1.9%	0.97

Two-Hour Count Summaries

Interval Start	N Northgate Way				N Northgate Way				Meridian Ave N				Meridian Ave N				15-min Total	Rolling One Hour	
	Eastbound		Westbound		Northbound		Southbound		UT		LT		RT						
4:00 PM	0	8	147	5	0	42	213	46	0	23	41	48	0	49	60	12	694	0	
4:15 PM	0	12	147	9	0	57	213	54	0	10	50	45	0	43	48	6	694	0	
4:30 PM	0	20	142	8	0	34	215	43	0	11	44	47	0	50	70	13	697	0	
4:45 PM	0	10	134	5	0	57	231	53	0	15	43	36	0	40	40	7	671	2,756	
5:00 PM	0	18	143	9	0	40	207	51	0	19	42	44	0	54	53	12	692	2,754	
5:15 PM	0	15	144	7	0	51	236	43	0	17	43	51	0	46	51	14	718	2,778	
5:30 PM	0	5	156	9	0	65	228	53	0	10	48	29	0	22	45	14	684	2,765	
5:45 PM	0	9	141	9	0	35	211	44	0	7	36	33	0	29	41	9	604	2,698	
Count Total	0	97	1,154	61	0	381	1,754	387	0	112	347	333	0	333	408	87	5,454	0	
Peak Hour	All	0	63	563	29	0	182	889	190	0	62	172	178	0	190	214	46	2,778	0
	HV	0	1	11	8	0	7	5	0	0	7	6	0	0	1	6	2	54	0
	HV%	-	2%	2%	28%	-	4%	1%	0%	-	11%	3%	0%	-	1%	3%	4%	2%	0

Note: Two-hour count summary volumes include heavy vehicles but exclude bicycles in overall count.

Interval Start	Heavy Vehicle Totals					Bicycles					Pedestrians (Crossing Leg)				
	EB	WB	NB	SB	Total	EB	WB	NB	SB	Total	East	West	North	South	Total
4:00 PM	10	15	2	5	32	0	0	0	1	1	13	12	13	10	48
4:15 PM	7	10	7	4	28	0	0	0	0	0	5	2	5	3	15
4:30 PM	10	3	2	4	19	0	0	0	0	0	5	7	3	6	21
4:45 PM	5	6	4	1	16	0	0	0	1	1	4	7	9	0	20
5:00 PM	3	1	5	3	12	0	0	1	0	1	7	7	15	6	35
5:15 PM	2	2	2	1	7	0	0	0	0	0	4	2	9	2	17
5:30 PM	3	4	2	3	12	0	0	1	0	1	8	8	8	5	29
5:45 PM	3	7	4	1	15	0	0	1	0	1	2	8	9	1	20
Count Total	43	48	28	22	141	0	0	3	2	5	48	53	71	33	205
Peak Hour	20	12	13	9	54	0	0	1	1	2	20	23	36	14	93

Two-Hour Count Summaries - Heavy Vehicles																		
Interval Start	N Northgate Way				N Northgate Way				Meridian Ave N				Meridian Ave N				15-min Total	Rolling One Hour
	Eastbound				Westbound				Northbound				Southbound					
	UT	LT	TH	RT	UT	LT	TH	RT	UT	LT	TH	RT	UT	LT	TH	RT		
4:00 PM	0	0	9	1	0	3	9	3	0	2	0	0	0	1	4	0	32	0
4:15 PM	0	0	5	2	0	5	4	1	0	2	4	1	0	1	3	0	28	0
4:30 PM	0	1	7	2	0	0	3	0	0	1	1	0	0	1	2	1	19	0
4:45 PM	0	0	3	2	0	5	1	0	0	2	2	0	0	0	0	1	16	95
5:00 PM	0	0	1	2	0	1	0	0	0	2	3	0	0	0	3	0	12	75
5:15 PM	0	0	0	2	0	1	1	0	0	2	0	0	0	0	1	0	7	54
5:30 PM	0	0	2	1	0	1	1	2	0	1	1	0	0	1	2	0	12	47
5:45 PM	0	0	1	2	0	1	5	1	0	0	3	1	0	0	1	0	15	46
Count Total	0	1	28	14	0	17	24	7	0	12	14	2	0	4	16	2	141	0
Peak Hour	0	1	11	8	0	7	5	0	0	7	6	0	0	1	6	2	54	0

Two-Hour Count Summaries - Bikes																	
Interval Start	N Northgate Way			N Northgate Way			Meridian Ave N			Meridian Ave N			15-min Total	Rolling One Hour			
	Eastbound			Westbound			Northbound			Southbound							
	LT	TH	RT	LT	TH	RT	LT	TH	RT	LT	TH	RT					
4:00 PM	0	0	0	0	0	0	0	0	0	0	0	0	1	0	1	0	
4:15 PM	0	0	0	0	0	0	0	0	0	0	0	0	0	0	0	0	
4:30 PM	0	0	0	0	0	0	0	0	0	0	0	0	0	0	0	0	
4:45 PM	0	0	0	0	0	0	0	0	0	0	0	0	1	0	1	2	
5:00 PM	0	0	0	0	0	0	0	0	1	0	0	0	0	0	1	2	
5:15 PM	0	0	0	0	0	0	0	0	0	0	0	0	0	0	0	2	
5:30 PM	0	0	0	0	0	0	0	0	1	0	0	0	0	0	1	3	
5:45 PM	0	0	0	0	0	0	0	0	1	0	0	0	0	0	1	3	
Count Total	0	0	0	0	0	0	0	0	3	0	0	2	0	5	0		
Peak Hour	0	0	0	0	0	0	0	0	1	0	0	1	0	2	0		

Note: U-Turn volumes for bikes are included in Left-Turn, if any.

Corliss Ave N N Northgate Way



Date: 02/07/2023
 Count Period: 7:00 AM to 9:00 AM
 Peak Hour: 7:45 AM to 8:45 AM

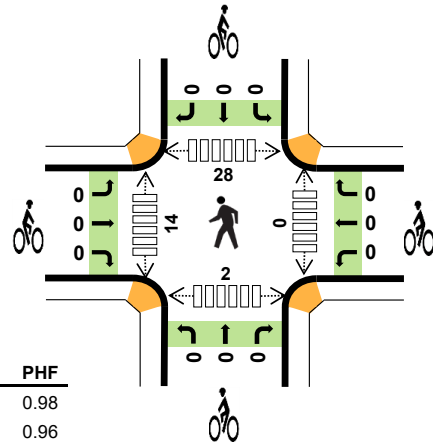
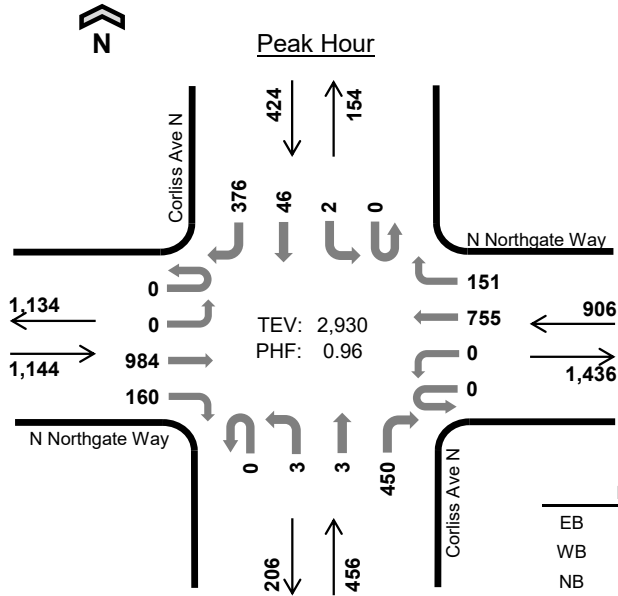

	HV %:	PHF
EB	3.1%	0.98
WB	3.4%	0.96
NB	6.1%	0.88
SB	4.0%	0.91
TOTAL	3.8%	0.96

Two-Hour Count Summaries

Interval Start	N Northgate Way				N Northgate Way				Corliss Ave N				Corliss Ave N				15-min Total	Rolling One Hour	
	Eastbound		Westbound		UT		TH		UT		TH		UT		TH				
7:00 AM	0	0	152	49	0	0	116	51	0	1	0	132	0	0	7	118	626	0	
7:15 AM	1	0	189	42	0	0	135	45	0	0	2	120	0	0	5	101	640	0	
7:30 AM	0	0	219	51	0	0	167	56	0	0	3	115	0	0	5	97	713	0	
7:45 AM	0	0	255	32	0	0	187	48	0	0	1	129	0	0	17	91	760	2,739	
8:00 AM	0	0	250	37	0	0	190	31	0	1	0	106	0	0	7	90	712	2,825	
8:15 AM	0	0	234	45	0	0	185	32	0	2	0	106	0	1	10	91	706	2,891	
8:30 AM	0	0	245	46	0	0	193	40	0	0	2	109	0	1	12	104	752	2,930	
8:45 AM	0	0	216	42	0	0	180	32	0	0	1	129	0	0	24	119	743	2,913	
Count Total	1	0	1,760	344	0	0	1,353	335	0	4	9	946	0	2	87	811	5,652	0	
Peak Hour	All	0	0	984	160	0	0	755	151	0	3	3	450	0	2	46	376	2,930	0
	HV	0	0	28	8	0	0	26	5	0	0	3	25	0	1	0	16	112	0
	HV%	-	-	3%	5%	-	-	3%	3%	-	0%	100%	6%	-	50%	0%	4%	4%	0

Note: Two-hour count summary volumes include heavy vehicles but exclude bicycles in overall count.

Interval Start	Heavy Vehicle Totals					Bicycles					Pedestrians (Crossing Leg)				
	EB	WB	NB	SB	Total	EB	WB	NB	SB	Total	East	West	North	South	Total
7:00 AM	4	13	9	5	31	0	0	0	1	1	0	1	3	0	4
7:15 AM	2	8	9	4	23	0	0	0	0	0	0	2	6	0	8
7:30 AM	7	4	7	10	28	0	0	0	0	0	0	1	8	0	9
7:45 AM	8	10	7	2	27	0	0	0	0	0	0	3	4	0	7
8:00 AM	5	8	7	5	25	0	0	0	0	0	0	6	10	2	18
8:15 AM	11	5	8	6	30	0	0	0	0	0	0	3	11	0	14
8:30 AM	12	8	6	4	30	0	0	0	0	0	0	2	3	0	5
8:45 AM	17	2	11	9	39	0	0	0	0	0	0	1	8	1	10
Count Total	66	58	64	45	233	0	0	0	1	1	0	19	53	3	75
Peak Hour	36	31	28	17	112	0	0	0	0	0	0	14	28	2	44

Two-Hour Count Summaries - Heavy Vehicles																		
Interval Start	N Northgate Way				N Northgate Way				Corliss Ave N				Corliss Ave N				15-min Total	Rolling One Hour
	Eastbound				Westbound				Northbound				Southbound					
	UT	LT	TH	RT	UT	LT	TH	RT	UT	LT	TH	RT	UT	LT	TH	RT		
7:00 AM	0	0	2	2	0	0	13	0	0	0	0	9	0	0	1	4	31	0
7:15 AM	0	0	1	1	0	0	4	4	0	0	2	7	0	0	0	4	23	0
7:30 AM	0	0	6	1	0	0	3	1	0	0	1	6	0	0	0	10	28	0
7:45 AM	0	0	6	2	0	0	9	1	0	0	1	6	0	0	0	2	27	109
8:00 AM	0	0	3	2	0	0	6	2	0	0	0	7	0	0	0	5	25	103
8:15 AM	0	0	10	1	0	0	5	0	0	0	0	8	0	1	0	5	30	110
8:30 AM	0	0	9	3	0	0	6	2	0	0	2	4	0	0	0	4	30	112
8:45 AM	0	0	15	2	0	0	1	1	0	0	1	10	0	0	0	9	39	124
Count Total	0	0	52	14	0	0	47	11	0	0	7	57	0	1	1	43	233	0
Peak Hour	0	0	28	8	0	0	26	5	0	0	3	25	0	1	0	16	112	0

Two-Hour Count Summaries - Bikes																	
Interval Start	N Northgate Way			N Northgate Way			Corliss Ave N			Corliss Ave N			15-min Total	Rolling One Hour			
	Eastbound			Westbound			Northbound			Southbound							
	LT	TH	RT	LT	TH	RT	LT	TH	RT	LT	TH	RT					
7:00 AM	0	0	0	0	0	0	0	0	0	0	0	0	1	0	1	0	0
7:15 AM	0	0	0	0	0	0	0	0	0	0	0	0	0	0	0	0	0
7:30 AM	0	0	0	0	0	0	0	0	0	0	0	0	0	0	0	0	0
7:45 AM	0	0	0	0	0	0	0	0	0	0	0	0	0	0	0	0	1
8:00 AM	0	0	0	0	0	0	0	0	0	0	0	0	0	0	0	0	0
8:15 AM	0	0	0	0	0	0	0	0	0	0	0	0	0	0	0	0	0
8:30 AM	0	0	0	0	0	0	0	0	0	0	0	0	0	0	0	0	0
8:45 AM	0	0	0	0	0	0	0	0	0	0	0	0	0	0	0	0	0
Count Total	0	0	0	0	0	0	0	0	0	0	0	0	1	0	1	0	0
Peak Hour	0	0	0	0	0	0	0	0	0	0	0	0	0	0	0	0	0

Note: U-Turn volumes for bikes are included in Left-Turn, if any.

Corliss Ave N N Northgate Way



Date: 02/07/2023
 Count Period: 4:00 PM to 6:00 PM
 Peak Hour: 4:30 PM to 5:30 PM

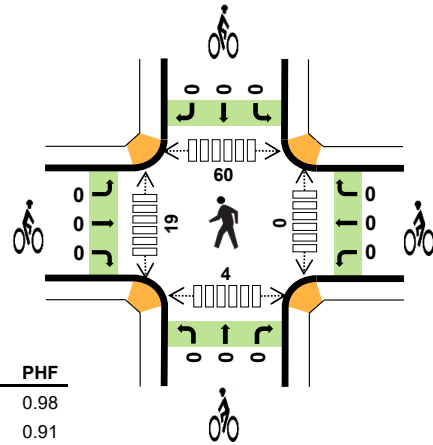
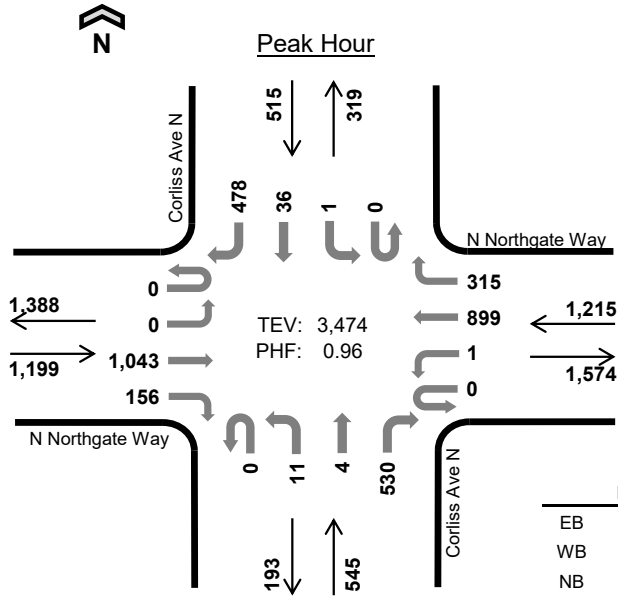

	HV %:	PHF
EB	1.1%	0.98
WB	0.9%	0.91
NB	6.1%	0.88
SB	1.7%	0.89
TOTAL	1.9%	0.96

Two-Hour Count Summaries

Interval Start	N Northgate Way Eastbound				N Northgate Way Westbound				Corliss Ave N Northbound				Corliss Ave N Southbound				15-min Total	Rolling One Hour	
	UT	LT	TH	RT	UT	LT	TH	RT	UT	LT	TH	RT	UT	LT	TH	RT			
4:00 PM	0	0	221	48	0	0	210	83	0	1	2	120	0	0	11	118	814	0	
4:15 PM	0	0	237	36	0	0	192	72	0	0	1	106	0	1	11	136	792	0	
4:30 PM	0	0	263	31	0	1	237	95	0	0	0	137	0	0	9	117	890	0	
4:45 PM	0	0	260	35	0	0	220	67	0	1	1	112	0	0	10	134	840	3,336	
5:00 PM	0	0	255	48	0	0	214	75	0	6	0	133	0	1	5	102	839	3,361	
5:15 PM	0	0	265	42	0	0	228	78	0	4	3	148	0	0	12	125	905	3,474	
5:30 PM	0	0	223	51	0	0	206	69	0	6	1	108	0	0	10	138	812	3,396	
5:45 PM	0	0	213	34	0	0	217	79	0	2	0	123	0	0	18	116	802	3,358	
Count Total	0	0	1,937	325	0	1	1,724	618	0	20	8	987	0	2	86	986	6,694	0	
Peak Hour	All	0	0	1,043	156	0	1	899	315	0	11	4	530	0	1	36	478	3,474	0
	HV	0	0	13	0	0	0	8	3	0	4	3	26	0	0	4	5	66	0
	HV%	-	-	1%	0%	-	0%	1%	1%	-	36%	75%	5%	-	0%	11%	1%	2%	0

Note: Two-hour count summary volumes include heavy vehicles but exclude bicycles in overall count.

Interval Start	Heavy Vehicle Totals					Bicycles					Pedestrians (Crossing Leg)				
	EB	WB	NB	SB	Total	EB	WB	NB	SB	Total	East	West	North	South	Total
4:00 PM	4	6	12	2	24	0	0	0	0	0	0	1	7	0	8
4:15 PM	8	3	4	3	18	0	1	0	1	2	0	7	16	2	25
4:30 PM	6	0	8	3	17	0	0	0	0	0	0	4	12	4	20
4:45 PM	2	5	4	1	12	0	0	0	0	0	0	3	8	0	11
5:00 PM	1	6	11	0	18	0	0	0	0	0	0	10	22	0	32
5:15 PM	4	0	10	5	19	0	0	0	0	0	0	2	18	0	20
5:30 PM	8	5	7	1	21	0	0	0	0	0	0	7	15	0	22
5:45 PM	1	2	6	1	10	0	0	0	0	0	0	8	10	0	18
Count Total	34	27	62	16	139	0	1	0	1	2	0	42	108	6	156
Peak Hour	13	11	33	9	66	0	0	0	0	0	0	19	60	4	83

Two-Hour Count Summaries - Heavy Vehicles																		
Interval Start	N Northgate Way				N Northgate Way				Corliss Ave N				Corliss Ave N				15-min Total	Rolling One Hour
	Eastbound				Westbound				Northbound				Southbound					
	UT	LT	TH	RT	UT	LT	TH	RT	UT	LT	TH	RT	UT	LT	TH	RT		
4:00 PM	0	0	2	2	0	0	5	1	0	0	2	10	0	0	1	1	24	0
4:15 PM	0	0	7	1	0	0	2	1	0	0	0	4	0	0	0	3	18	0
4:30 PM	0	0	6	0	0	0	0	0	0	0	0	8	0	0	1	2	17	0
4:45 PM	0	0	2	0	0	0	4	1	0	0	1	3	0	0	0	1	12	71
5:00 PM	0	0	1	0	0	0	4	2	0	1	0	10	0	0	0	0	18	65
5:15 PM	0	0	4	0	0	0	0	0	0	3	2	5	0	0	3	2	19	66
5:30 PM	0	0	8	0	0	0	3	2	0	0	0	7	0	0	1	0	21	70
5:45 PM	0	0	0	1	0	0	1	1	0	0	0	6	0	0	0	1	10	68
Count Total	0	0	30	4	0	0	19	8	0	4	5	53	0	0	6	10	139	0
Peak Hour	0	0	13	0	0	0	8	3	0	4	3	26	0	0	4	5	66	0

Two-Hour Count Summaries - Bikes																		
Interval Start	N Northgate Way			N Northgate Way			Corliss Ave N			Corliss Ave N			15-min Total	Rolling One Hour				
	Eastbound			Westbound			Northbound			Southbound								
	LT	TH	RT	LT	TH	RT	LT	TH	RT	LT	TH	RT						
4:00 PM	0	0	0	0	0	0	0	0	0	0	0	0	0	0	0	0	0	0
4:15 PM	0	0	0	0	0	1	0	0	0	0	0	1	0	0	1	2	0	0
4:30 PM	0	0	0	0	0	0	0	0	0	0	0	0	0	0	0	0	0	0
4:45 PM	0	0	0	0	0	0	0	0	0	0	0	0	0	0	0	0	0	2
5:00 PM	0	0	0	0	0	0	0	0	0	0	0	0	0	0	0	0	0	2
5:15 PM	0	0	0	0	0	0	0	0	0	0	0	0	0	0	0	0	0	0
5:30 PM	0	0	0	0	0	0	0	0	0	0	0	0	0	0	0	0	0	0
5:45 PM	0	0	0	0	0	0	0	0	0	0	0	0	0	0	0	0	0	0
Count Total	0	0	0	0	0	1	0	0	0	0	0	1	0	0	1	2	0	0
Peak Hour	0	0	0	0	0	0	0	0	0	0	0	0	0	0	0	0	0	0

Note: U-Turn volumes for bikes are included in Left-Turn, if any.



Date: 01/24/2023

Count Period: 7:00 AM to 9:00 AM

Peak Hour: 8:00 AM to 9:00 AM

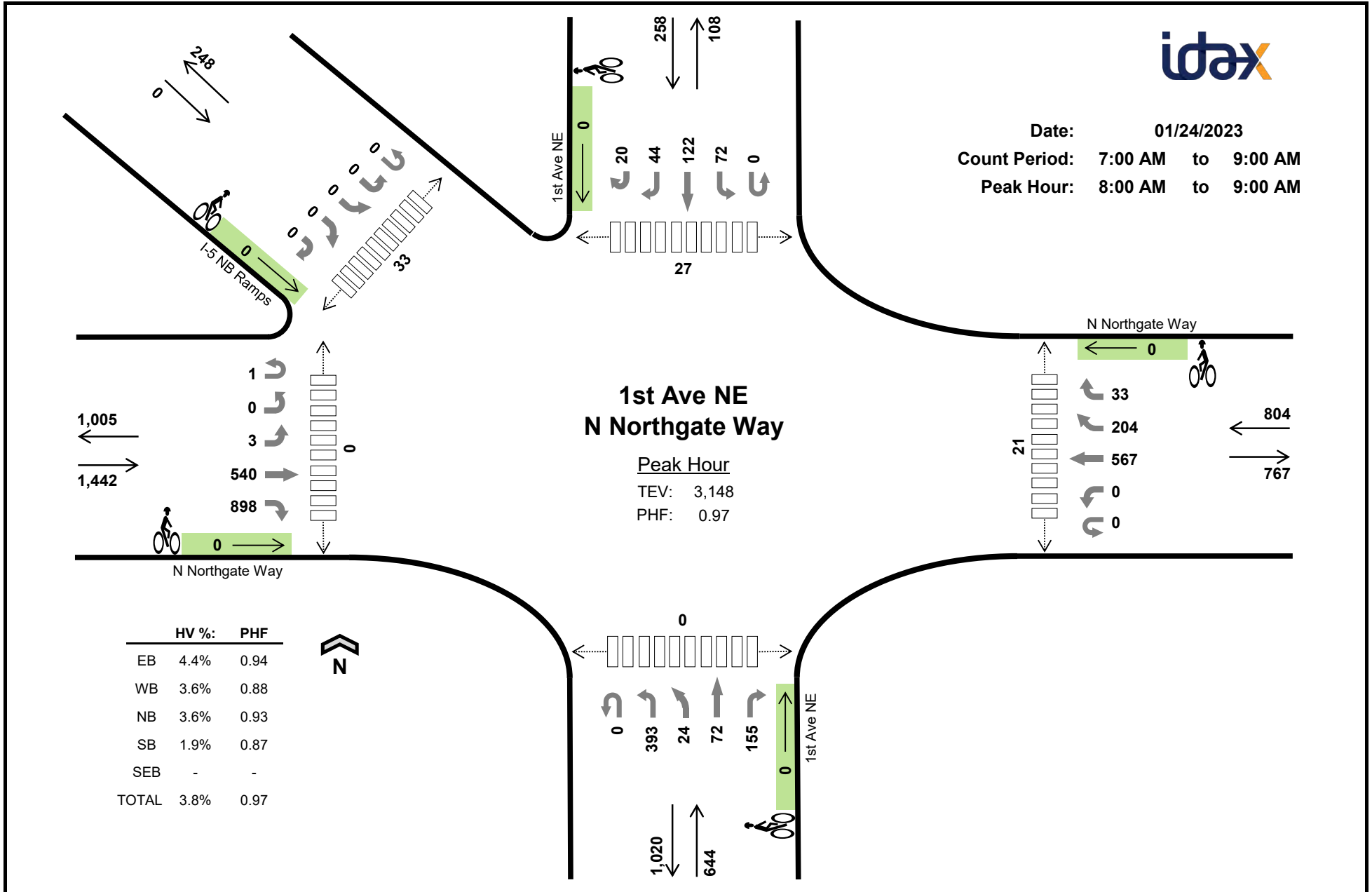

	HV %:	PHF
EB	4.4%	0.94
WB	3.6%	0.88
NB	3.6%	0.93
SB	1.9%	0.87
SEB	-	-
TOTAL	3.8%	0.97



Two-Hour Count Summaries

Interval Start	N Northgate Way					N Northgate Way					1st Ave NE					1st Ave NE					I-5 NB Ramps					15-min Total	Rolling One Hour	
	Eastbound					Westbound					Northbound					Southbound					Southeastbound							
	UT	HL	LT	TH	RT	UT	LT	TH	BR	RT	UT	LT	BL	TH	RT	UT	LT	TH	RT	HR	UT	HL	BL	BR	HR			
7:00 AM	0	0	0	74	219	0	0	105	36	4	0	48	0	12	28	0	2	25	5	3	0	0	0	0	0	561	0	
7:15 AM	0	0	0	87	220	0	0	101	61	7	0	82	5	11	34	0	9	26	9	8	0	0	0	0	0	660	0	
7:30 AM	0	0	0	99	269	0	0	114	50	5	0	88	4	19	45	0	10	33	15	19	0	0	0	0	0	770	0	
7:45 AM	0	0	0	123	267	0	0	118	43	4	0	103	9	16	41	0	16	40	9	8	0	0	0	0	0	797	2,788	
8:00 AM	0	0	1	142	240	0	0	115	50	5	0	95	5	14	39	0	19	29	9	7	0	0	0	0	0	770	2,997	
8:15 AM	0	0	1	129	217	0	0	170	51	8	0	87	6	22	36	0	14	29	9	7	0	0	0	0	0	786	3,123	
8:30 AM	0	0	1	126	214	0	0	144	51	9	0	103	8	20	43	0	19	28	13	1	0	0	0	0	0	780	3,133	
8:45 AM	1	0	0	143	227	0	0	138	52	11	0	108	5	16	37	0	20	36	13	5	0	0	0	0	0	812	3,148	
Count Total	1	0	3	923	1,873	0	0	1,005	394	53	0	714	42	130	303	0	109	246	82	58	0	0	0	0	0	5,936	0	
Peak Hour	All	1	0	3	540	898	0	0	567	204	33	0	393	24	72	155	0	72	122	44	20	0	0	0	0	0	3,148	0
	HV	0	0	0	24	39	0	0	21	6	2	0	12	1	1	9	0	1	3	1	0	0	0	0	0	0	120	0
	HV%	0%	-	0%	4%	4%	-	-	4%	3%	6%	-	3%	4%	1%	6%	-	1%	2%	2%	0%	-	-	-	-	-	4%	0

Note: Two-hour count summary volumes include heavy vehicles but exclude bicycles in overall count.

Interval Start	Heavy Vehicle Totals						Bicycles						Pedestrians (Crossing Leg)					
	EB	WB	NB	SB	SEB	Total	EB	WB	NB	SB	SEB	Total	East	West	North	South	Northwest	Total
7:00 AM	8	6	3	0	0	17	0	0	0	0	0	0	3	0	4	0	4	11
7:15 AM	8	2	7	1	0	18	0	0	1	0	0	1	3	0	4	2	5	14
7:30 AM	12	8	8	0	0	28	0	0	0	0	0	0	9	0	4	1	4	18
7:45 AM	20	6	7	2	0	35	0	0	0	0	0	0	4	0	8	1	7	20
8:00 AM	20	10	6	1	0	37	0	0	0	0	0	0	5	0	5	0	6	16
8:15 AM	15	5	4	3	0	27	0	0	0	0	0	0	5	0	10	0	10	25
8:30 AM	11	6	8	0	0	25	0	0	0	0	0	0	5	0	7	0	9	21
8:45 AM	17	8	5	1	0	31	0	0	0	0	0	0	6	0	5	0	8	19
Count Total	111	51	48	8	0	218	0	0	1	0	0	1	40	0	47	4	53	144
Peak Hr	63	29	23	5	0	120	0	0	0	0	0	0	21	0	27	0	33	81

Two-Hour Count Summaries - Heavy Vehicles

Interval Start	N Northgate Way Eastbound					N Northgate Way Westbound					1st Ave NE Northbound					1st Ave NE Southbound					n/a Southeastbound					15-min Total	Rolling One Hour
	UT	HL	LT	TH	RT	UT	LT	TH	BR	RT	UT	LT	BL	TH	RT	UT	LT	TH	RT	HR	UT	HL	BL	BR	HR		
7:00 AM	0	0	0	2	6	0	0	6	0	0	0	3	0	0	0	0	0	0	0	0	0	0	0	0	0	17	0
7:15 AM	0	0	0	4	4	0	0	1	1	0	0	4	0	0	3	0	0	0	1	0	0	0	0	0	0	18	0
7:30 AM	0	0	0	3	9	0	0	6	2	0	0	2	0	2	4	0	0	0	0	0	0	0	0	0	0	28	0
7:45 AM	0	0	0	6	14	0	0	5	0	1	0	5	0	1	1	0	1	0	1	0	0	0	0	0	0	35	98
8:00 AM	0	0	0	5	15	0	0	8	1	1	0	3	0	0	3	0	0	1	0	0	0	0	0	0	0	37	118
8:15 AM	0	0	0	5	10	0	0	4	1	0	0	3	0	0	1	0	1	2	0	0	0	0	0	0	0	27	127
8:30 AM	0	0	0	6	5	0	0	4	2	0	0	4	1	0	3	0	0	0	0	0	0	0	0	0	0	25	124
8:45 AM	0	0	0	8	9	0	0	5	2	1	0	2	0	1	2	0	0	0	1	0	0	0	0	0	0	31	120
Count Total	0	0	0	39	72	0	0	39	9	3	0	26	1	4	17	0	2	3	3	0	0	0	0	0	0	218	0
Peak Hour	0	0	0	24	39	0	0	21	6	2	0	12	1	1	9	0	1	3	1	0	0	0	0	0	0	120	0

Two-Hour Count Summaries - Bikes

Interval Start	N Northgate Way Eastbound					N Northgate Way Westbound					1st Ave NE Northbound					1st Ave NE Southbound					n/a Southeastbound					15-min Total	Rolling One Hour
	UT	HL	LT	TH	RT	UT	LT	TH	BR	RT	UT	LT	BL	TH	RT	UT	LT	TH	RT	HR	UT	HL	BL	BR	HR		
7:00 AM	0	0	0	0	0	0	0	0	0	0	0	0	0	0	0	0	0	0	0	0	0	0	0	0	0	0	0
7:15 AM	0	0	0	0	0	0	0	0	0	0	0	0	0	1	0	0	0	0	0	0	0	0	0	0	0	1	0
7:30 AM	0	0	0	0	0	0	0	0	0	0	0	0	0	0	0	0	0	0	0	0	0	0	0	0	0	0	0
7:45 AM	0	0	0	0	0	0	0	0	0	0	0	0	0	0	0	0	0	0	0	0	0	0	0	0	0	0	1
8:00 AM	0	0	0	0	0	0	0	0	0	0	0	0	0	0	0	0	0	0	0	0	0	0	0	0	0	0	1
8:15 AM	0	0	0	0	0	0	0	0	0	0	0	0	0	0	0	0	0	0	0	0	0	0	0	0	0	0	0
8:30 AM	0	0	0	0	0	0	0	0	0	0	0	0	0	0	0	0	0	0	0	0	0	0	0	0	0	0	0
8:45 AM	0	0	0	0	0	0	0	0	0	0	0	0	0	0	0	0	0	0	0	0	0	0	0	0	0	0	0
Count Total	0	0	0	0	0	0	0	0	0	0	0	0	0	1	0	0	0	0	0	0	0	0	0	0	0	1	0
Peak Hour	0	0	0	0	0	0	0	0	0	0	0	0	0	0	0	0	0	0	0	0	0	0	0	0	0	0	0



Date: 01/24/2023
 Count Period: 4:00 PM to 6:00 PM
 Peak Hour: 4:45 PM to 5:45 PM

1st Ave NE N Northgate Way

Peak Hour
 TEV: 3,898
 PHF: 0.98

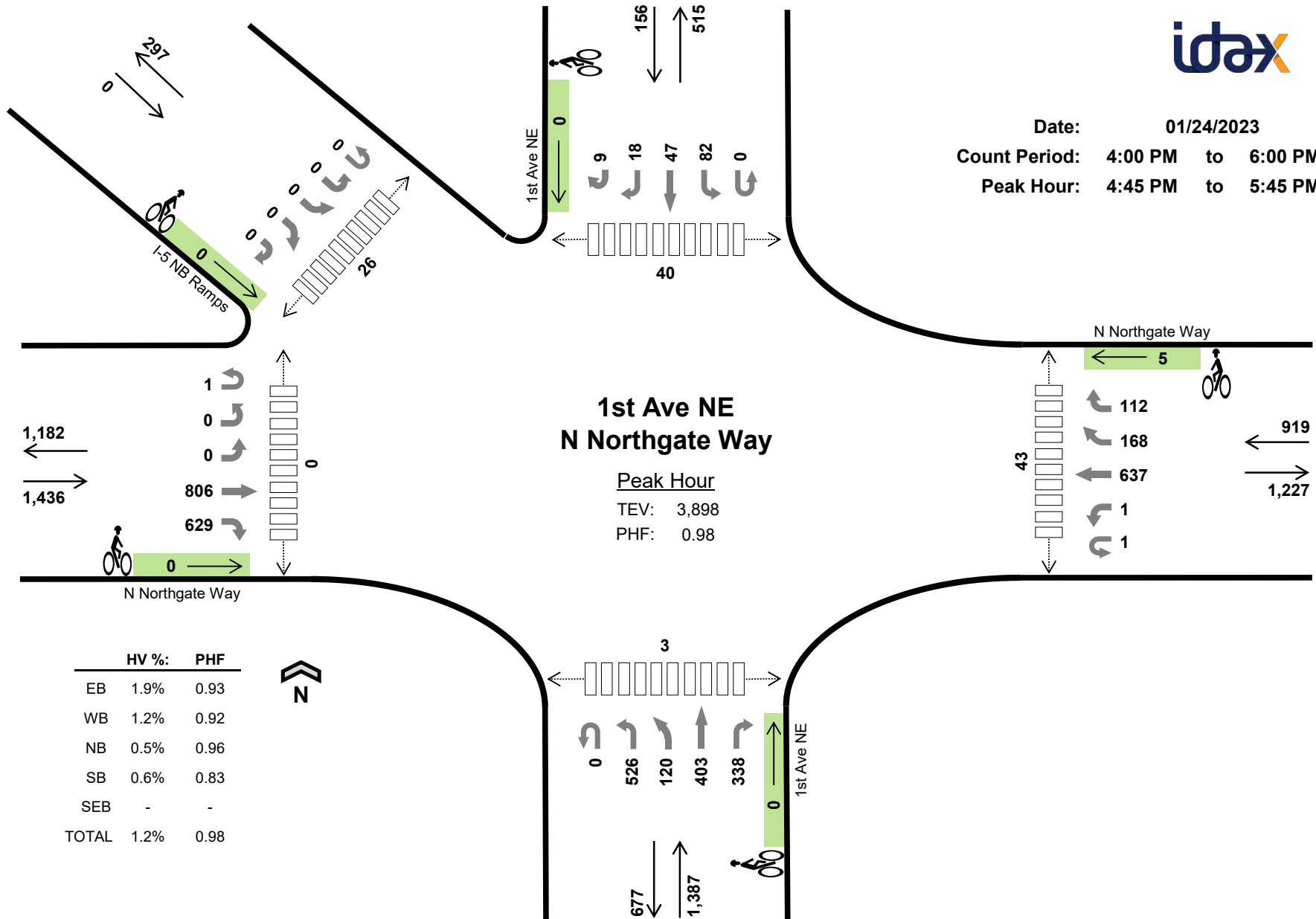

	HV %:	PHF
EB	1.9%	0.93
WB	1.2%	0.92
NB	0.5%	0.96
SB	0.6%	0.83
SEB	-	-
TOTAL	1.2%	0.98



Two-Hour Count Summaries

Interval Start	N Northgate Way					N Northgate Way					1st Ave NE					1st Ave NE					I-5 NB Ramps					15-min Total	Rolling One Hour	
	Eastbound					Westbound					Northbound					Southbound					Southeastbound							
	UT	HL	LT	TH	RT	UT	LT	TH	BR	RT	UT	LT	BL	TH	RT	UT	LT	TH	RT	HR	UT	HL	BL	BR	HR			
4:00 PM	0	0	1	220	171	0	0	162	48	29	0	107	28	71	80	0	17	11	13	3	0	0	0	0	0	961	0	
4:15 PM	0	0	1	203	178	0	1	188	35	22	0	112	26	68	83	0	30	7	6	4	0	0	0	0	0	964	0	
4:30 PM	0	0	1	204	160	0	0	138	34	20	0	101	24	77	92	0	21	11	6	5	0	0	0	0	0	894	0	
4:45 PM	0	0	0	222	134	0	1	165	50	35	0	133	28	93	92	0	19	13	4	2	0	0	0	0	0	991	3,810	
5:00 PM	0	0	0	206	156	0	0	160	36	17	0	119	39	107	98	0	23	12	7	5	0	0	0	0	0	985	3,834	
5:15 PM	1	0	0	201	183	0	0	152	37	28	0	133	28	92	83	0	23	14	6	1	0	0	0	0	0	982	3,852	
5:30 PM	0	0	0	177	156	1	0	160	45	32	0	141	25	111	65	0	17	8	1	1	0	0	0	0	0	940	3,898	
5:45 PM	1	0	1	193	149	0	0	137	38	26	0	126	23	87	81	0	6	10	10	1	0	0	0	0	0	889	3,796	
Count Total	2	0	4	1,626	1,287	1	2	1,262	323	209	0	972	221	706	674	0	156	86	53	22	0	0	0	0	0	7,606	0	
Peak Hour	All	1	0	0	806	629	1	1	637	168	112	0	526	120	403	338	0	82	47	18	9	0	0	0	0	0	3,898	0
	HV	0	0	0	12	15	0	0	10	1	0	0	4	0	2	1	0	0	0	1	0	0	0	0	0	0	46	0
	HV%	0%	-	-	1%	2%	0%	0%	2%	1%	0%	-	1%	0%	0%	0%	-	0%	0%	6%	0%	-	-	-	-	-	1%	0

Note: Two-hour count summary volumes include heavy vehicles but exclude bicycles in overall count.

Interval Start	Heavy Vehicle Totals						Bicycles						Pedestrians (Crossing Leg)					
	EB	WB	NB	SB	SEB	Total	EB	WB	NB	SB	SEB	Total	East	West	North	South	Northwest	Total
4:00 PM	13	3	6	0	0	22	0	0	0	0	0	0	9	0	11	1	9	30
4:15 PM	11	6	4	0	0	21	0	0	0	0	0	0	7	0	9	1	9	26
4:30 PM	14	2	2	0	0	18	1	0	0	0	0	1	12	0	10	1	12	35
4:45 PM	6	1	4	1	0	12	0	1	0	0	0	1	7	0	12	0	12	31
5:00 PM	5	4	0	0	0	9	0	2	0	0	0	2	12	0	13	0	3	28
5:15 PM	7	5	2	0	0	14	0	2	0	0	0	2	11	0	7	2	5	25
5:30 PM	9	1	1	0	0	11	0	0	0	0	0	0	13	0	8	1	6	28
5:45 PM	4	6	3	0	0	13	0	0	0	0	0	0	6	0	6	0	7	19
Count Total	69	28	22	1	0	120	1	5	0	0	0	6	77	0	76	6	63	222
Peak Hr	27	11	7	1	0	46	0	5	0	0	0	5	43	0	40	3	26	112

Two-Hour Count Summaries - Heavy Vehicles

Interval Start	N Northgate Way Eastbound					N Northgate Way Westbound					1st Ave NE Northbound					1st Ave NE Southbound					n/a Southeastbound					15-min Total	Rolling One Hour
	UT	HL	LT	TH	RT	UT	LT	TH	BR	RT	UT	LT	BL	TH	RT	UT	LT	TH	RT	HR	UT	HL	BL	BR	HR		
4:00 PM	0	0	0	3	10	0	0	3	0	0	0	5	0	1	0	0	0	0	0	0	0	0	0	0	0	22	0
4:15 PM	0	0	0	3	8	0	0	4	0	2	0	3	0	0	1	0	0	0	0	0	0	0	0	0	0	21	0
4:30 PM	0	0	0	10	4	0	0	1	0	1	0	2	0	0	0	0	0	0	0	0	0	0	0	0	0	18	0
4:45 PM	0	0	0	3	3	0	0	0	1	0	0	3	0	0	1	0	0	0	1	0	0	0	0	0	0	12	73
5:00 PM	0	0	0	2	3	0	0	4	0	0	0	0	0	0	0	0	0	0	0	0	0	0	0	0	0	9	60
5:15 PM	0	0	0	2	5	0	0	5	0	0	0	0	0	2	0	0	0	0	0	0	0	0	0	0	0	14	53
5:30 PM	0	0	0	5	4	0	0	1	0	0	0	1	0	0	0	0	0	0	0	0	0	0	0	0	0	11	46
5:45 PM	0	0	0	1	3	0	0	5	1	0	0	1	1	0	1	0	0	0	0	0	0	0	0	0	0	13	47
Count Total	0	0	0	29	40	0	0	23	2	3	0	15	1	3	3	0	0	0	1	0	0	0	0	0	0	120	0
Peak Hour	0	0	0	12	15	0	0	10	1	0	0	4	0	2	1	0	0	0	1	0	0	0	0	0	0	46	0

Two-Hour Count Summaries - Bikes

Interval Start	N Northgate Way Eastbound					N Northgate Way Westbound					1st Ave NE Northbound					1st Ave NE Southbound					n/a Southeastbound					15-min Total	Rolling One Hour	
	UT	HL	LT	TH	RT	UT	LT	TH	BR	RT	UT	LT	BL	TH	RT	UT	LT	TH	RT	HR	UT	HL	BL	BR	HR			
4:00 PM	0	0	0	0	0	0	0	0	0	0	0	0	0	0	0	0	0	0	0	0	0	0	0	0	0	0	0	0
4:15 PM	0	0	0	0	0	0	0	0	0	0	0	0	0	0	0	0	0	0	0	0	0	0	0	0	0	0	0	0
4:30 PM	0	0	0	0	1	0	0	0	0	0	0	0	0	0	0	0	0	0	0	0	0	0	0	0	0	1	0	
4:45 PM	0	0	0	0	0	0	0	1	0	0	0	0	0	0	0	0	0	0	0	0	0	0	0	0	0	1	2	
5:00 PM	0	0	0	0	0	0	0	2	0	0	0	0	0	0	0	0	0	0	0	0	0	0	0	0	0	2	4	
5:15 PM	0	0	0	0	0	0	0	2	0	0	0	0	0	0	0	0	0	0	0	0	0	0	0	0	0	2	6	
5:30 PM	0	0	0	0	0	0	0	0	0	0	0	0	0	0	0	0	0	0	0	0	0	0	0	0	0	0	5	
5:45 PM	0	0	0	0	0	0	0	0	0	0	0	0	0	0	0	0	0	0	0	0	0	0	0	0	0	0	4	
Count Total	0	0	0	0	1	0	0	5	0	0	0	0	0	0	0	0	0	0	0	0	0	0	0	0	0	6	0	
Peak Hour	0	0	0	0	0	0	0	5	0	0	0	0	0	0	0	0	0	0	0	0	0	0	0	0	0	5	0	



1st Ave NE NE 107th St

Date: 01/31/2023

Count Period: 7:00 AM to 9:00 AM

Peak Hour: 7:15 AM to 8:15 AM

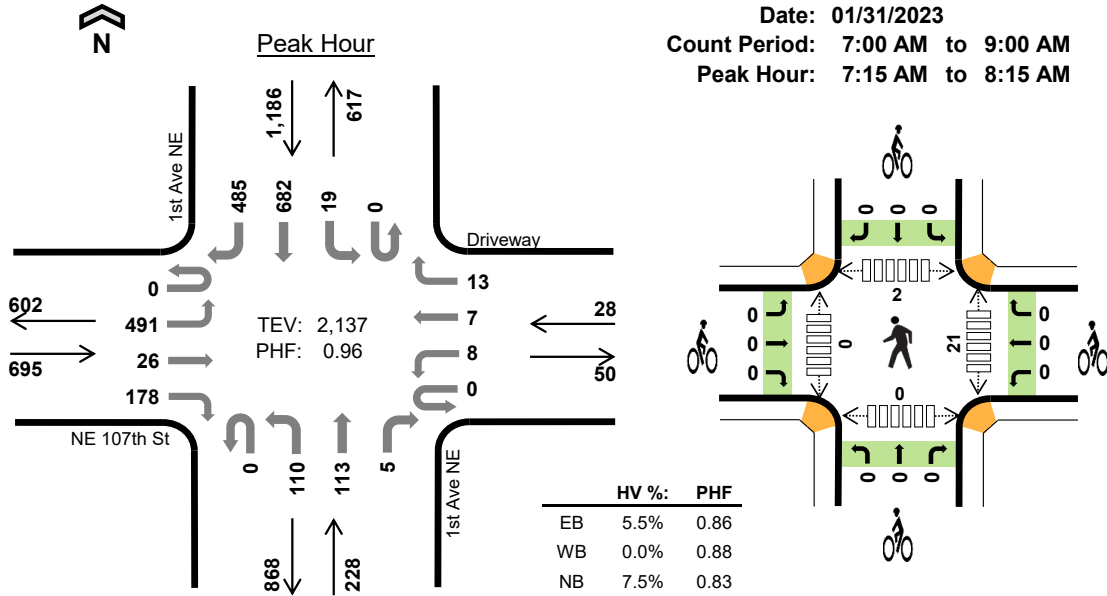

Two-Hour Count Summaries

Interval Start	NE 107th St				Driveway				1st Ave NE				1st Ave NE				15-min Total	Rolling One Hour	
	Eastbound		Westbound		Westbound		Northbound		Northbound		Southbound		Southbound						
	UT	LT	TH	RT	UT	LT	TH	RT	UT	LT	TH	RT	UT	LT	TH	RT			
7:00 AM	0	81	6	29	0	1	3	1	0	21	14	0	0	1	169	84	410	0	
7:15 AM	0	109	4	48	0	3	1	2	0	30	30	1	0	5	161	105	499	0	
7:30 AM	0	109	4	40	0	1	2	5	0	22	21	0	0	6	201	129	540	0	
7:45 AM	0	127	8	44	0	2	1	5	0	33	33	3	0	2	178	119	555	2,004	
8:00 AM	0	146	10	46	0	2	3	1	0	25	29	1	0	6	142	132	543	2,137	
8:15 AM	0	118	5	31	0	4	2	6	0	32	23	1	0	4	143	112	481	2,119	
8:30 AM	0	105	3	33	0	2	0	8	0	31	41	1	0	6	133	87	450	2,029	
8:45 AM	0	130	8	50	0	0	1	7	0	27	39	0	0	9	101	78	450	1,924	
Count Total	0	925	48	321	0	15	13	35	0	221	230	7	0	39	1,228	846	3,928	0	
Peak Hour	All	0	491	26	178	0	8	7	13	0	110	113	5	0	19	682	485	2,137	0
	HV	0	31	0	7	0	0	0	0	0	13	4	0	0	0	21	27	103	0
	HV%	-	6%	0%	4%	-	0%	0%	0%	-	12%	4%	0%	-	0%	3%	6%	5%	0

Note: Two-hour count summary volumes include heavy vehicles but exclude bicycles in overall count.

Interval Start	Heavy Vehicle Totals					Bicycles					Pedestrians (Crossing Leg)				
	EB	WB	NB	SB	Total	EB	WB	NB	SB	Total	East	West	North	South	Total
7:00 AM	8	0	6	10	24	0	0	0	0	0	7	0	0	0	7
7:15 AM	10	0	6	18	34	0	0	0	0	0	6	0	0	0	6
7:30 AM	6	0	3	9	18	0	0	0	0	0	7	0	0	0	7
7:45 AM	11	0	4	8	23	0	0	0	0	0	6	0	2	0	8
8:00 AM	11	0	4	13	28	0	0	0	0	0	2	0	0	0	2
8:15 AM	4	0	7	11	22	0	1	0	0	1	9	0	0	0	9
8:30 AM	8	0	4	9	21	0	0	0	0	0	1	0	0	0	1
8:45 AM	8	0	3	14	25	0	0	0	0	0	4	0	0	0	4
Count Total	66	0	37	92	195	0	1	0	0	1	42	0	2	0	44
Peak Hour	38	0	17	48	103	0	0	0	0	0	21	0	2	0	23

Two-Hour Count Summaries - Heavy Vehicles																		
Interval Start	NE 107th St				Driveway				1st Ave NE				1st Ave NE				15-min Total	Rolling One Hour
	Eastbound				Westbound				Northbound				Southbound					
	UT	LT	TH	RT	UT	LT	TH	RT	UT	LT	TH	RT	UT	LT	TH	RT		
7:00 AM	0	7	0	1	0	0	0	0	0	5	1	0	0	0	8	2	24	0
7:15 AM	0	8	0	2	0	0	0	0	0	4	2	0	0	0	5	13	34	0
7:30 AM	0	6	0	0	0	0	0	0	0	2	1	0	0	0	4	5	18	0
7:45 AM	0	7	0	4	0	0	0	0	0	3	1	0	0	0	4	4	23	99
8:00 AM	0	10	0	1	0	0	0	0	0	4	0	0	0	0	8	5	28	103
8:15 AM	0	4	0	0	0	0	0	0	0	6	1	0	0	0	6	5	22	91
8:30 AM	0	8	0	0	0	0	0	0	0	4	0	0	0	1	2	6	21	94
8:45 AM	0	7	0	1	0	0	0	0	0	3	0	0	0	0	4	10	25	96
Count Total	0	57	0	9	0	0	0	0	0	31	6	0	0	1	41	50	195	0
Peak Hour	0	31	0	7	0	0	0	0	0	13	4	0	0	0	21	27	103	0

Two-Hour Count Summaries - Bikes																		
Interval Start	NE 107th St			Driveway			1st Ave NE			1st Ave NE			15-min Total	Rolling One Hour				
	Eastbound			Westbound			Northbound			Southbound								
	LT	TH	RT	LT	TH	RT	LT	TH	RT	LT	TH	RT						
7:00 AM	0	0	0	0	0	0	0	0	0	0	0	0	0	0	0	0	0	0
7:15 AM	0	0	0	0	0	0	0	0	0	0	0	0	0	0	0	0	0	0
7:30 AM	0	0	0	0	0	0	0	0	0	0	0	0	0	0	0	0	0	0
7:45 AM	0	0	0	0	0	0	0	0	0	0	0	0	0	0	0	0	0	0
8:00 AM	0	0	0	0	0	0	0	0	0	0	0	0	0	0	0	0	0	0
8:15 AM	0	0	0	1	0	0	0	0	0	0	0	0	0	0	0	1	1	1
8:30 AM	0	0	0	0	0	0	0	0	0	0	0	0	0	0	0	0	0	1
8:45 AM	0	0	0	0	0	0	0	0	0	0	0	0	0	0	0	0	0	1
Count Total	0	0	0	1	0	0	0	0	0	0	0	0	0	0	0	1	1	0
Peak Hour	0	0	0	0	0	0	0	0	0	0	0	0	0	0	0	0	0	0

Note: U-Turn volumes for bikes are included in Left-Turn, if any.

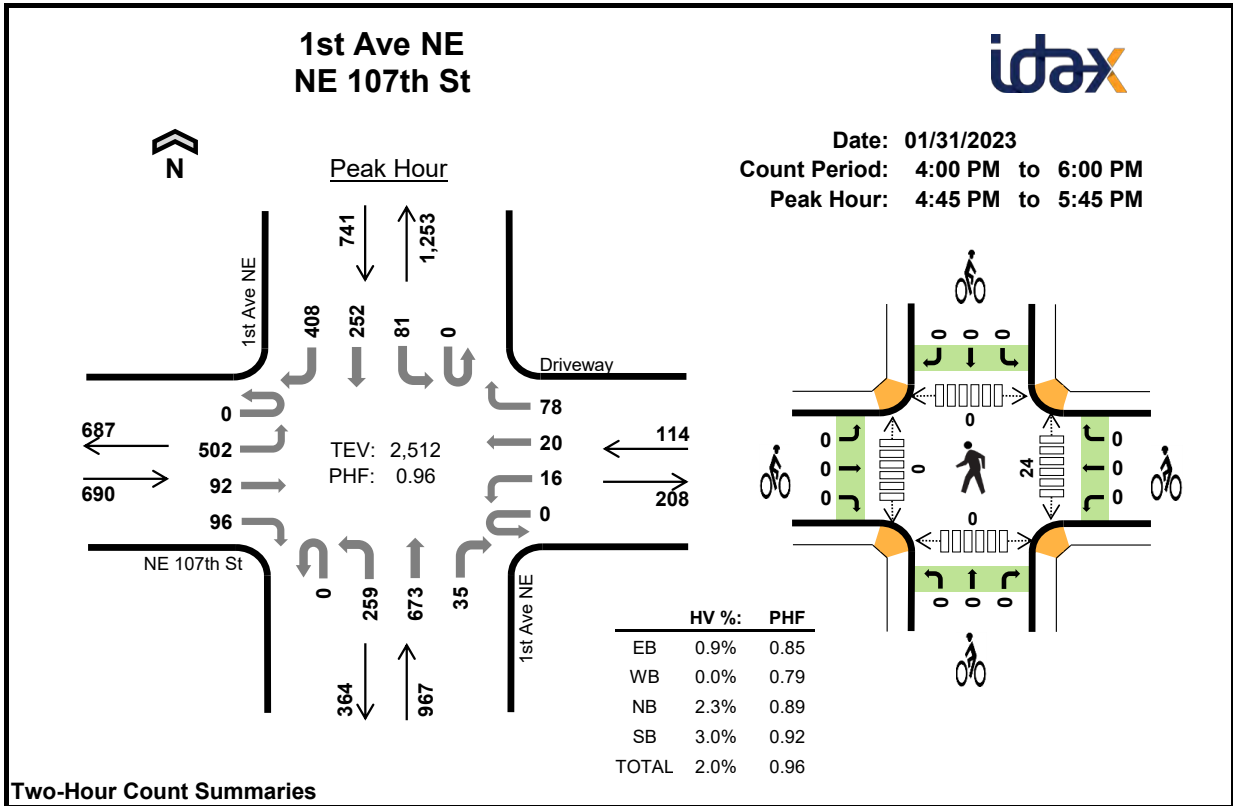

Two-Hour Count Summaries

Interval Start	NE 107th St				Driveway				1st Ave NE				1st Ave NE				15-min Total	Rolling One Hour	
	Eastbound		Westbound		Westbound		Northbound		Northbound		Southbound		Southbound						
	UT	LT	TH	RT	UT	LT	TH	RT	UT	LT	TH	RT	UT	LT	TH	RT			
4:00 PM	0	163	17	24	0	4	5	18	0	63	173	5	0	14	56	99	641	0	
4:15 PM	0	156	27	17	0	5	4	17	0	54	146	7	0	13	61	103	610	0	
4:30 PM	0	126	20	30	0	2	9	15	0	57	176	9	0	11	45	95	595	0	
4:45 PM	0	113	19	21	0	6	4	14	0	59	162	10	0	23	70	108	609	2,455	
5:00 PM	0	113	18	23	0	4	3	19	0	73	191	9	0	19	49	104	625	2,439	
5:15 PM	0	125	27	27	0	5	7	16	0	70	162	11	0	20	63	93	626	2,455	
5:30 PM	0	151	28	25	0	1	6	29	0	57	158	5	0	19	70	103	652	2,512	
5:45 PM	0	137	22	31	0	10	7	14	0	72	145	9	0	22	59	64	592	2,495	
Count Total	0	1,084	178	198	0	37	45	142	0	505	1,313	65	0	141	473	769	4,950	0	
Peak Hour	All	0	502	92	96	0	16	20	78	0	259	673	35	0	81	252	408	2,512	0
	HV	0	5	0	1	0	0	0	0	0	20	2	0	0	0	13	9	50	0
	HV%	-	1%	0%	1%	-	0%	0%	0%	-	8%	0%	0%	-	0%	5%	2%	2%	0

Note: Two-hour count summary volumes include heavy vehicles but exclude bicycles in overall count.

Interval Start	Heavy Vehicle Totals					Bicycles					Pedestrians (Crossing Leg)				
	EB	WB	NB	SB	Total	EB	WB	NB	SB	Total	East	West	North	South	Total
4:00 PM	2	0	9	13	24	0	0	0	0	0	11	0	1	0	12
4:15 PM	1	0	4	8	13	0	0	0	0	0	2	0	0	0	2
4:30 PM	2	0	8	10	20	0	0	0	0	0	9	0	0	0	9
4:45 PM	2	0	4	5	11	0	0	0	0	0	4	0	0	0	4
5:00 PM	1	0	8	6	15	0	0	0	0	0	13	0	0	0	13
5:15 PM	3	0	3	6	12	0	0	0	0	0	4	0	0	0	4
5:30 PM	0	0	7	5	12	0	0	0	0	0	3	0	0	0	3
5:45 PM	5	0	6	9	20	0	0	0	0	0	1	0	0	0	1
Count Total	16	0	49	62	127	0	0	0	0	0	47	0	1	0	48
Peak Hour	6	0	22	22	50	0	0	0	0	0	24	0	0	0	24

Two-Hour Count Summaries - Heavy Vehicles																		
Interval Start	NE 107th St				Driveway				1st Ave NE				1st Ave NE				15-min Total	Rolling One Hour
	Eastbound				Westbound				Northbound				Southbound					
	UT	LT	TH	RT	UT	LT	TH	RT	UT	LT	TH	RT	UT	LT	TH	RT		
4:00 PM	0	2	0	0	0	0	0	0	0	5	4	0	0	0	7	6	24	0
4:15 PM	0	1	0	0	0	0	0	0	0	4	0	0	0	0	4	4	13	0
4:30 PM	0	1	0	1	0	0	0	0	0	7	1	0	0	0	5	5	20	0
4:45 PM	0	2	0	0	0	0	0	0	0	4	0	0	0	0	3	2	11	68
5:00 PM	0	1	0	0	0	0	0	0	0	6	2	0	0	0	3	3	15	59
5:15 PM	0	2	0	1	0	0	0	0	0	3	0	0	0	0	4	2	12	58
5:30 PM	0	0	0	0	0	0	0	0	0	7	0	0	0	0	3	2	12	50
5:45 PM	0	4	0	1	0	0	0	0	0	4	2	0	0	0	6	3	20	59
Count Total	0	13	0	3	0	0	0	0	0	40	9	0	0	0	35	27	127	0
Peak Hour	0	5	0	1	0	0	0	0	0	20	2	0	0	0	13	9	50	0
Two-Hour Count Summaries - Bikes																		
Interval Start	NE 107th St			Driveway			1st Ave NE			1st Ave NE			15-min Total	Rolling One Hour				
	Eastbound			Westbound			Northbound			Southbound								
	LT	TH	RT	LT	TH	RT	LT	TH	RT	LT	TH	RT						
4:00 PM	0	0	0	0	0	0	0	0	0	0	0	0	0	0	0	0	0	0
4:15 PM	0	0	0	0	0	0	0	0	0	0	0	0	0	0	0	0	0	0
4:30 PM	0	0	0	0	0	0	0	0	0	0	0	0	0	0	0	0	0	0
4:45 PM	0	0	0	0	0	0	0	0	0	0	0	0	0	0	0	0	0	0
5:00 PM	0	0	0	0	0	0	0	0	0	0	0	0	0	0	0	0	0	0
5:15 PM	0	0	0	0	0	0	0	0	0	0	0	0	0	0	0	0	0	0
5:30 PM	0	0	0	0	0	0	0	0	0	0	0	0	0	0	0	0	0	0
5:45 PM	0	0	0	0	0	0	0	0	0	0	0	0	0	0	0	0	0	0
Count Total	0	0	0	0	0	0	0	0	0	0	0	0	0	0	0	0	0	0
Peak Hour	0	0	0	0	0	0	0	0	0	0	0	0	0	0	0	0	0	0
<i>Note: U-Turn volumes for bikes are included in Left-Turn, if any.</i>																		

Meridian Ave N N 120th St



Peak Hour

Date: 01/24/2023
Count Period: 7:00 AM to 9:00 AM
Peak Hour: 8:00 AM to 9:00 AM

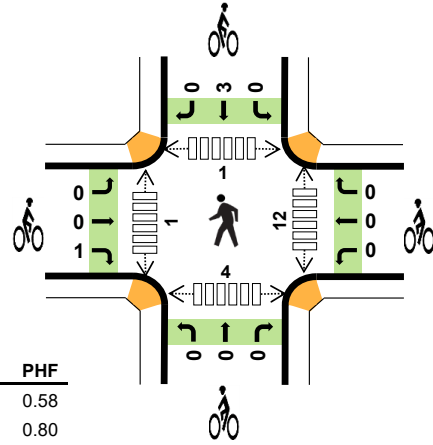
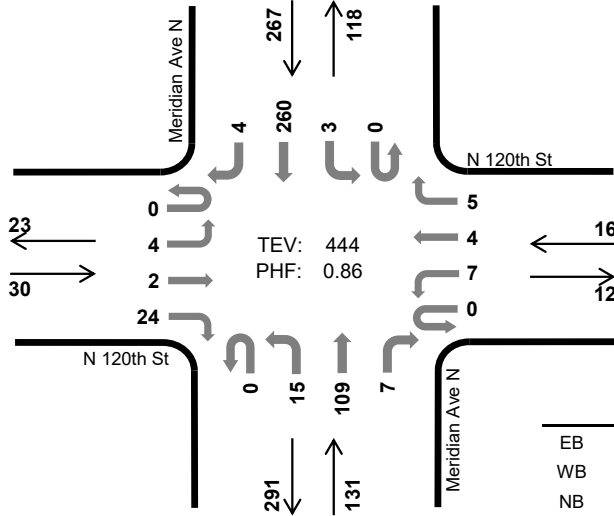

	HV %:	PHF
EB	13.3%	0.58
WB	0.0%	0.80
NB	9.9%	0.91
SB	4.1%	0.81
TOTAL	6.3%	0.86

Two-Hour Count Summaries

Interval Start	N 120th St Eastbound				N 120th St Westbound				Meridian Ave N Northbound				Meridian Ave N Southbound				15-min Total	Rolling One Hour	
	UT	LT	TH	RT	UT	LT	TH	RT	UT	LT	TH	RT	UT	LT	TH	RT			
7:00 AM	0	0	1	7	0	2	0	1	0	2	15	2	0	1	38	0	69	0	
7:15 AM	0	0	0	4	0	5	0	0	0	0	11	1	0	0	48	2	71	0	
7:30 AM	0	0	2	3	0	0	1	0	0	2	23	10	0	0	52	0	93	0	
7:45 AM	0	0	0	3	0	1	0	1	0	3	28	11	0	4	65	0	116	349	
8:00 AM	0	0	0	6	0	1	1	0	0	4	21	3	0	0	68	1	105	385	
8:15 AM	0	1	0	2	0	2	0	3	0	6	25	1	0	0	45	1	86	400	
8:30 AM	0	1	2	10	0	3	1	1	0	2	34	0	0	1	69	0	124	431	
8:45 AM	0	2	0	6	0	1	2	1	0	3	29	3	0	2	78	2	129	444	
Count Total	0	4	5	41	0	15	5	7	0	22	186	31	0	8	463	6	793	0	
Peak Hour	All	0	4	2	24	0	7	4	5	0	15	109	7	0	3	260	4	444	0
	HV	0	0	1	3	0	0	0	0	0	3	9	1	0	0	11	0	28	0
	HV%	-	0%	50%	13%	-	0%	0%	0%	-	20%	8%	14%	-	0%	4%	0%	6%	0

Note: Two-hour count summary volumes include heavy vehicles but exclude bicycles in overall count.

Interval Start	Heavy Vehicle Totals					Bicycles					Pedestrians (Crossing Leg)				
	EB	WB	NB	SB	Total	EB	WB	NB	SB	Total	East	West	North	South	Total
7:00 AM	2	1	2	3	8	0	0	0	1	1	1	0	0	1	2
7:15 AM	0	1	1	0	2	0	0	2	1	3	0	0	0	1	1
7:30 AM	0	0	2	2	4	0	1	0	1	2	1	0	0	1	2
7:45 AM	1	0	3	2	6	0	0	0	0	0	1	0	0	2	3
8:00 AM	1	0	3	4	8	0	0	0	0	0	2	0	0	3	5
8:15 AM	0	0	5	1	6	1	0	0	2	3	3	0	0	0	3
8:30 AM	3	0	0	4	7	0	0	0	1	1	4	0	1	0	5
8:45 AM	0	0	5	2	7	0	0	0	0	0	3	1	0	1	5
Count Total	7	2	21	18	48	1	1	2	6	10	15	1	1	9	26
Peak Hour	4	0	13	11	28	1	0	0	3	4	12	1	1	4	18

Two-Hour Count Summaries - Heavy Vehicles																		
Interval Start	N 120th St				N 120th St				Meridian Ave N				Meridian Ave N				15-min Total	Rolling One Hour
	Eastbound				Westbound				Northbound				Southbound					
	UT	LT	TH	RT	UT	LT	TH	RT	UT	LT	TH	RT	UT	LT	TH	RT		
7:00 AM	0	0	0	2	0	0	0	1	0	0	2	0	0	0	3	0	8	0
7:15 AM	0	0	0	0	0	1	0	0	0	0	1	0	0	0	0	0	2	0
7:30 AM	0	0	0	0	0	0	0	0	0	1	1	0	0	0	2	0	4	0
7:45 AM	0	0	0	1	0	0	0	0	0	1	2	0	0	1	1	0	6	20
8:00 AM	0	0	0	1	0	0	0	0	0	1	2	0	0	0	4	0	8	20
8:15 AM	0	0	0	0	0	0	0	0	0	2	2	1	0	0	1	0	6	24
8:30 AM	0	0	1	2	0	0	0	0	0	0	0	0	0	0	4	0	7	27
8:45 AM	0	0	0	0	0	0	0	0	0	0	5	0	0	0	2	0	7	28
Count Total	0	0	1	6	0	1	0	1	0	5	15	1	0	1	17	0	48	0
Peak Hour	0	0	1	3	0	0	0	0	0	3	9	1	0	0	11	0	28	0
Two-Hour Count Summaries - Bikes																		
Interval Start	N 120th St			N 120th St			Meridian Ave N			Meridian Ave N			15-min Total	Rolling One Hour				
	Eastbound			Westbound			Northbound			Southbound								
	LT	TH	RT	LT	TH	RT	LT	TH	RT	LT	TH	RT						
7:00 AM	0	0	0	0	0	0	0	0	0	0	0	0	0	1	1	0	1	0
7:15 AM	0	0	0	0	0	0	0	1	1	0	0	1	0	0	1	0	3	0
7:30 AM	0	0	0	0	1	0	0	0	0	0	0	0	0	0	1	0	2	0
7:45 AM	0	0	0	0	0	0	0	0	0	0	0	0	0	0	0	0	0	6
8:00 AM	0	0	0	0	0	0	0	0	0	0	0	0	0	0	0	0	0	5
8:15 AM	0	0	1	0	0	0	0	0	0	0	0	0	0	2	0	0	3	5
8:30 AM	0	0	0	0	0	0	0	0	0	0	0	0	0	1	0	0	1	4
8:45 AM	0	0	0	0	0	0	0	0	0	0	0	0	0	0	0	0	0	4
Count Total	0	0	1	1	0	0	0	1	1	0	0	4	2	10	0	0	10	0
Peak Hour	0	0	1	0	0	0	0	0	0	0	0	0	3	0	0	0	4	0
<i>Note: U-Turn volumes for bikes are included in Left-Turn, if any.</i>																		

Meridian Ave N N 120th St



Peak Hour

Date: 01/24/2023
Count Period: 4:00 PM to 6:00 PM
Peak Hour: 4:00 PM to 5:00 PM

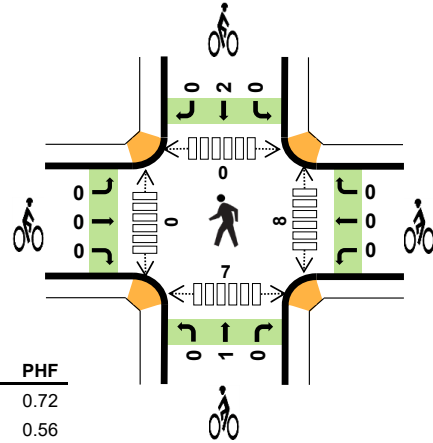
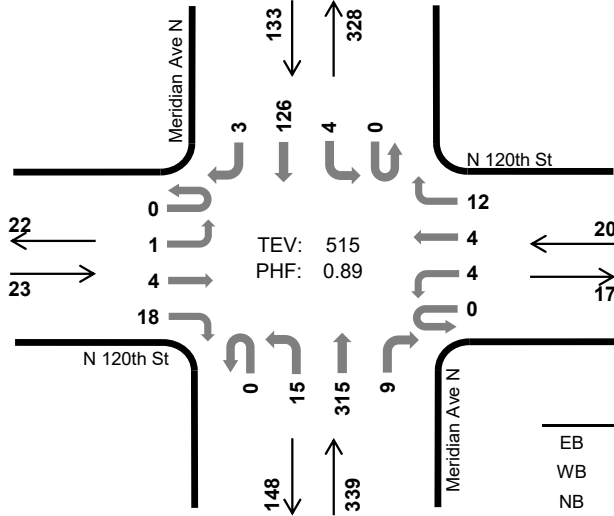

	HV %:	PHF
EB	8.7%	0.72
WB	5.0%	0.56
NB	2.1%	0.86
SB	6.0%	0.92
TOTAL	3.5%	0.89

Two-Hour Count Summaries

Interval Start	N 120th St Eastbound				N 120th St Westbound				Meridian Ave N Northbound				Meridian Ave N Southbound				15-min Total	Rolling One Hour	
	UT	LT	TH	RT	UT	LT	TH	RT	UT	LT	TH	RT	UT	LT	TH	RT			
4:00 PM	0	0	3	4	0	1	1	4	0	4	82	2	0	2	34	0	137	0	
4:15 PM	0	1	0	5	0	0	1	1	0	3	69	3	0	1	32	2	118	0	
4:30 PM	0	0	1	7	0	1	2	6	0	5	92	2	0	0	28	1	145	0	
4:45 PM	0	0	0	2	0	2	0	1	0	3	72	2	0	1	32	0	115	515	
5:00 PM	0	0	0	7	0	1	1	1	0	4	74	5	0	2	36	0	131	509	
5:15 PM	0	2	0	0	0	3	1	2	0	2	72	2	0	1	28	0	113	504	
5:30 PM	0	1	1	2	0	0	3	0	0	25	74	2	0	0	28	0	136	495	
5:45 PM	0	3	1	1	0	2	0	0	0	5	70	4	0	1	34	2	123	503	
Count Total	0	7	6	28	0	10	9	15	0	51	605	22	0	8	252	5	1,018	0	
Peak Hour	All	0	1	4	18	0	4	4	12	0	15	315	9	0	4	126	3	515	0
	HV	0	0	1	1	0	1	0	0	0	0	7	0	0	0	7	1	18	0
	HV%	-	0%	25%	6%	-	25%	0%	0%	-	0%	2%	0%	-	0%	6%	33%	3%	0

Note: Two-hour count summary volumes include heavy vehicles but exclude bicycles in overall count.

Interval Start	Heavy Vehicle Totals					Bicycles					Pedestrians (Crossing Leg)				
	EB	WB	NB	SB	Total	EB	WB	NB	SB	Total	East	West	North	South	Total
4:00 PM	1	0	1	3	5	0	0	1	1	2	0	0	0	0	0
4:15 PM	0	0	1	2	3	0	0	0	0	0	7	0	0	0	2
4:30 PM	1	0	3	2	6	0	0	0	0	0	0	0	0	2	2
4:45 PM	0	1	2	1	4	0	0	0	1	1	1	0	0	3	4
5:00 PM	0	0	2	1	3	0	0	0	0	0	4	1	0	4	9
5:15 PM	0	0	1	2	3	0	0	0	0	0	3	0	0	0	3
5:30 PM	0	0	2	1	3	0	0	0	0	0	2	0	0	4	6
5:45 PM	0	0	2	2	4	0	1	0	0	1	0	0	0	0	0
Count Total	2	1	14	14	31	0	1	1	2	4	17	1	0	15	33
Peak Hour	2	1	7	8	18	0	0	1	2	3	8	0	0	7	15

Two-Hour Count Summaries - Heavy Vehicles																		
Interval Start	N 120th St				N 120th St				Meridian Ave N				Meridian Ave N				15-min Total	Rolling One Hour
	Eastbound				Westbound				Northbound				Southbound					
	UT	LT	TH	RT	UT	LT	TH	RT	UT	LT	TH	RT	UT	LT	TH	RT		
4:00 PM	0	0	1	0	0	0	0	0	0	0	1	0	0	0	3	0	5	0
4:15 PM	0	0	0	0	0	0	0	0	0	0	1	0	0	0	2	0	3	0
4:30 PM	0	0	0	1	0	0	0	0	0	0	3	0	0	0	1	1	6	0
4:45 PM	0	0	0	0	0	1	0	0	0	0	2	0	0	0	1	0	4	18
5:00 PM	0	0	0	0	0	0	0	0	0	0	2	0	0	0	1	0	3	16
5:15 PM	0	0	0	0	0	0	0	0	0	0	1	0	0	0	2	0	3	16
5:30 PM	0	0	0	0	0	0	0	0	0	0	2	0	0	0	1	0	3	13
5:45 PM	0	0	0	0	0	0	0	0	0	0	2	0	0	0	2	0	4	13
Count Total	0	0	1	1	0	1	0	0	0	0	14	0	0	0	13	1	31	0
Peak Hour	0	0	1	1	0	1	0	0	0	0	7	0	0	0	7	1	18	0

Two-Hour Count Summaries - Bikes																	
Interval Start	N 120th St			N 120th St			Meridian Ave N			Meridian Ave N			15-min Total	Rolling One Hour			
	Eastbound			Westbound			Northbound			Southbound							
	LT	TH	RT	LT	TH	RT	LT	TH	RT	LT	TH	RT					
4:00 PM	0	0	0	0	0	0	0	1	0	0	1	0	2	0			
4:15 PM	0	0	0	0	0	0	0	0	0	0	0	0	0	0			
4:30 PM	0	0	0	0	0	0	0	0	0	0	0	0	0	0			
4:45 PM	0	0	0	0	0	0	0	0	0	0	1	0	1	3			
5:00 PM	0	0	0	0	0	0	0	0	0	0	0	0	0	1			
5:15 PM	0	0	0	0	0	0	0	0	0	0	0	0	0	1			
5:30 PM	0	0	0	0	0	0	0	0	0	0	0	0	0	1			
5:45 PM	0	0	0	0	1	0	0	0	0	0	0	0	1	1			
Count Total	0	0	0	0	1	0	0	1	0	0	2	0	4	0			
Peak Hour	0	0	0	0	0	0	0	1	0	0	2	0	3	0			

Note: U-Turn volumes for bikes are included in Left-Turn, if any.

1st Ave NE N 117th St



Date: 07/18/2023
 Count Period: 7:00 AM to 9:00 AM
 Peak Hour: 7:45 AM to 8:45 AM

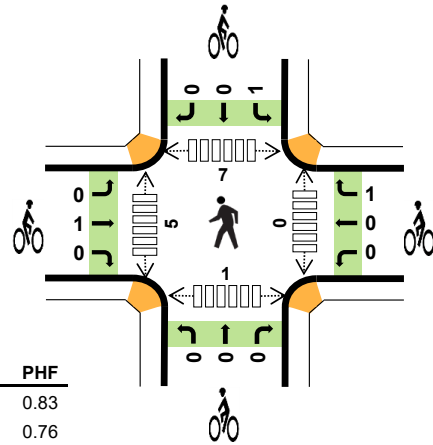
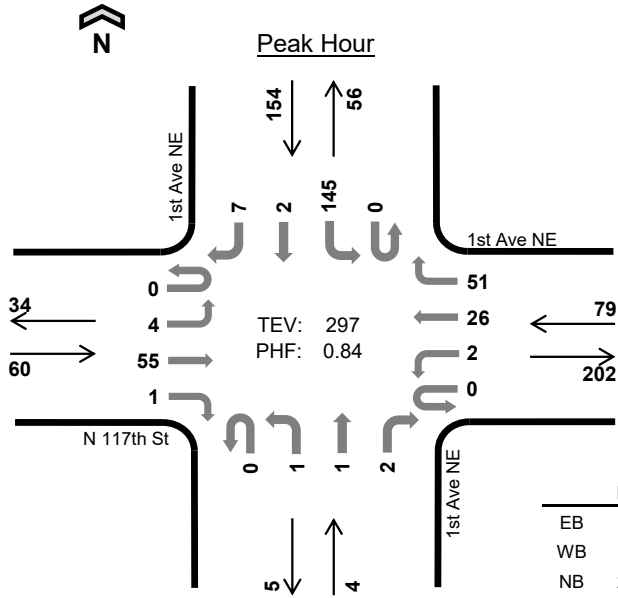

	HV %:	PHF
EB	8.3%	0.83
WB	12.7%	0.76
NB	25.0%	0.50
SB	2.6%	0.92
TOTAL	6.7%	0.84

Two-Hour Count Summaries

Interval Start	N 117th St				1st Ave NE				1st Ave NE				1st Ave NE				15-min Total	Rolling One Hour	
	Eastbound				Westbound				Northbound				Southbound						
	UT	LT	TH	RT	UT	LT	TH	RT	UT	LT	TH	RT	UT	LT	TH	RT			
7:00 AM	0	3	8	0	0	0	5	4	0	0	0	0	0	21	0	0	41	0	
7:15 AM	0	0	11	0	0	0	3	10	0	0	0	1	0	25	1	1	52	0	
7:30 AM	0	0	19	0	0	0	8	3	0	0	1	0	0	27	0	2	60	0	
7:45 AM	0	2	15	0	0	0	4	9	0	0	0	0	0	32	0	2	64	217	
8:00 AM	0	2	11	0	0	0	1	14	0	0	0	1	0	38	1	3	71	247	
8:15 AM	0	0	18	0	0	1	8	17	0	0	1	1	0	41	0	1	88	283	
8:30 AM	0	0	11	1	0	1	13	11	0	1	0	0	0	34	1	1	74	297	
8:45 AM	0	2	7	0	0	1	4	13	0	0	0	2	0	25	0	1	55	288	
Count Total	0	9	100	1	0	3	46	81	0	1	2	5	0	243	3	11	505	0	
Peak Hour	All	0	4	55	1	0	2	26	51	0	1	1	2	0	145	2	7	297	0
	HV	0	1	4	0	0	1	4	5	0	0	1	0	0	3	0	1	20	0
	HV%	-	25%	7%	0%	-	50%	15%	10%	-	0%	100%	0%	-	2%	0%	14%	7%	0

Note: Two-hour count summary volumes include heavy vehicles but exclude bicycles in overall count.

Interval Start	Heavy Vehicle Totals					Bicycles					Pedestrians (Crossing Leg)					
	EB	WB	NB	SB	Total	EB	WB	NB	SB	Total	East	West	North	South	Total	
7:00 AM	0	0	0	0	0	0	0	0	0	0	0	2	0	0	5	7
7:15 AM	0	2	0	0	2	0	0	0	0	0	1	0	2	1	4	4
7:30 AM	0	1	0	1	2	0	0	0	2	2	0	1	0	0	1	1
7:45 AM	1	2	0	2	5	1	0	0	0	1	0	1	2	1	4	4
8:00 AM	1	0	0	2	3	0	1	0	0	1	0	0	0	0	0	0
8:15 AM	2	5	1	0	8	0	0	0	1	1	0	2	3	0	5	5
8:30 AM	1	3	0	0	4	0	0	0	0	0	0	2	2	0	4	4
8:45 AM	0	0	0	1	1	0	0	0	0	0	0	0	2	0	2	2
Count Total	5	13	1	6	25	1	1	0	3	5	1	8	11	7	27	27
Peak Hour	5	10	1	4	20	1	1	0	1	3	0	5	7	1	13	13

Two-Hour Count Summaries - Heavy Vehicles																		
Interval Start	N 117th St				1st Ave NE				1st Ave NE				1st Ave NE				15-min Total	Rolling One Hour
	Eastbound				Westbound				Northbound				Southbound					
	UT	LT	TH	RT	UT	LT	TH	RT	UT	LT	TH	RT	UT	LT	TH	RT		
7:00 AM	0	0	0	0	0	0	0	0	0	0	0	0	0	0	0	0	0	
7:15 AM	0	0	0	0	0	0	1	1	0	0	0	0	0	0	0	0	2	
7:30 AM	0	0	0	0	0	0	1	0	0	0	0	0	0	0	0	1	2	
7:45 AM	0	1	0	0	0	0	0	2	0	0	0	0	0	2	0	0	5	
8:00 AM	0	0	1	0	0	0	0	0	0	0	0	0	0	1	0	1	3	
8:15 AM	0	0	2	0	0	1	2	2	0	0	1	0	0	0	0	0	8	
8:30 AM	0	0	1	0	0	0	2	1	0	0	0	0	0	0	0	0	4	
8:45 AM	0	0	0	0	0	0	0	0	0	0	0	0	0	0	0	1	1	
Count Total	0	1	4	0	0	1	6	6	0	0	1	0	0	3	0	3	25	
Peak Hour	0	1	4	0	0	1	4	5	0	0	1	0	0	3	0	1	20	

Two-Hour Count Summaries - Bikes																	
Interval Start	N 117th St			1st Ave NE			1st Ave NE			1st Ave NE			15-min Total	Rolling One Hour			
	Eastbound			Westbound			Northbound			Southbound							
	LT	TH	RT	LT	TH	RT	LT	TH	RT	LT	TH	RT					
7:00 AM	0	0	0	0	0	0	0	0	0	0	0	0	0	0	0	0	
7:15 AM	0	0	0	0	0	0	0	0	0	0	0	0	0	0	0	0	
7:30 AM	0	0	0	0	0	0	0	0	0	0	0	2	0	0	0	2	
7:45 AM	0	1	0	0	0	0	0	0	0	0	0	0	0	0	0	1	
8:00 AM	0	0	0	0	0	0	1	0	0	0	0	0	0	0	0	1	
8:15 AM	0	0	0	0	0	0	0	0	0	0	0	1	0	0	0	1	
8:30 AM	0	0	0	0	0	0	0	0	0	0	0	0	0	0	0	0	
8:45 AM	0	0	0	0	0	0	0	0	0	0	0	0	0	0	0	0	
Count Total	0	1	0	0	0	0	1	0	0	0	0	3	0	0	0	5	
Peak Hour	0	1	0	0	0	0	1	0	0	0	0	1	0	0	0	3	

Note: U-Turn volumes for bikes are included in Left-Turn, if any.

1st Ave NE N 117th St



Date: 07/18/2023
 Count Period: 4:00 PM to 6:00 PM
 Peak Hour: 4:30 PM to 5:30 PM

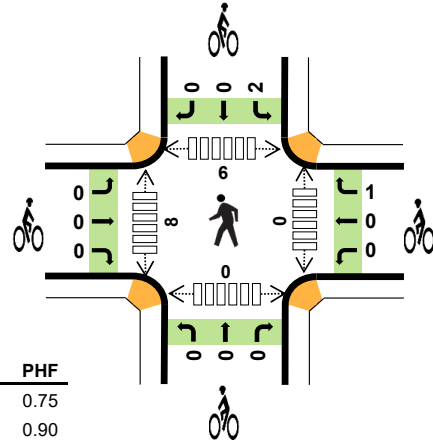
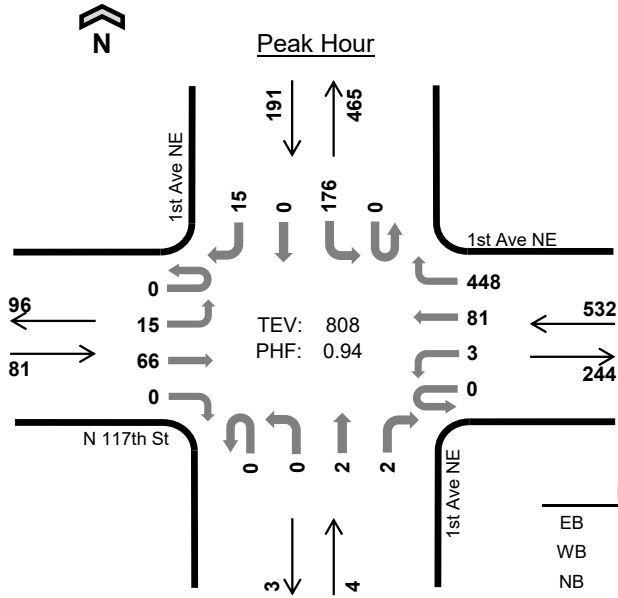

	HV %:	PHF
EB	1.2%	0.75
WB	0.9%	0.90
NB	0.0%	0.50
SB	0.0%	0.81
TOTAL	0.7%	0.94

Two-Hour Count Summaries

Interval Start	N 117th St				1st Ave NE				1st Ave NE				1st Ave NE				15-min Total	Rolling One Hour	
	Eastbound				Westbound				Northbound				Southbound						
	UT	LT	TH	RT	UT	LT	TH	RT	UT	LT	TH	RT	UT	LT	TH	RT			
4:00 PM	0	0	10	1	1	0	11	81	0	0	0	1	0	31	2	2	140	0	
4:15 PM	0	3	8	0	0	0	9	118	0	0	0	1	0	28	1	2	170	0	
4:30 PM	0	1	16	0	0	0	23	125	0	0	1	0	0	41	0	5	212	0	
4:45 PM	0	5	15	0	0	1	26	99	0	0	0	0	0	35	0	5	186	708	
5:00 PM	0	2	15	0	0	0	19	117	0	0	1	1	0	57	0	2	214	782	
5:15 PM	0	7	20	0	0	2	13	107	0	0	0	1	0	43	0	3	196	808	
5:30 PM	0	5	14	0	0	0	13	128	0	0	0	1	0	32	0	4	197	793	
5:45 PM	0	3	7	0	0	0	16	127	0	0	0	0	0	40	0	3	196	803	
Count Total	0	26	105	1	1	3	130	902	0	0	2	5	0	307	3	26	1,511	0	
Peak Hour	All	0	15	66	0	0	3	81	448	0	0	2	2	0	176	0	15	808	0
	HV	0	0	1	0	0	0	0	5	0	0	0	0	0	0	0	0	6	0
	HV%	-	0%	2%	-	-	0%	0%	1%	-	-	0%	0%	-	0%	-	0%	1%	0

Note: Two-hour count summary volumes include heavy vehicles but exclude bicycles in overall count.

Interval Start	Heavy Vehicle Totals					Bicycles					Pedestrians (Crossing Leg)				
	EB	WB	NB	SB	Total	EB	WB	NB	SB	Total	East	West	North	South	Total
4:00 PM	0	0	0	0	0	0	1	0	0	1	0	0	1	0	1
4:15 PM	0	1	0	0	1	0	0	0	1	1	0	0	2	0	2
4:30 PM	0	3	0	0	3	0	0	0	0	0	0	2	2	0	4
4:45 PM	1	2	0	0	3	0	1	0	2	3	0	4	2	0	6
5:00 PM	0	0	0	0	0	0	0	0	0	0	0	0	0	0	0
5:15 PM	0	0	0	0	0	0	0	0	0	0	0	2	2	0	4
5:30 PM	0	0	0	1	1	0	0	0	0	0	0	0	0	0	0
5:45 PM	0	0	0	0	0	0	0	1	0	1	1	1	2	1	5
Count Total	1	6	0	1	8	0	2	1	3	6	1	9	11	1	22
Peak Hour	1	5	0	0	6	0	1	0	2	3	0	8	6	0	14

Two-Hour Count Summaries - Heavy Vehicles																		
Interval Start	N 117th St				1st Ave NE				1st Ave NE				1st Ave NE				15-min Total	Rolling One Hour
	Eastbound				Westbound				Northbound				Southbound					
	UT	LT	TH	RT	UT	LT	TH	RT	UT	LT	TH	RT	UT	LT	TH	RT		
4:00 PM	0	0	0	0	0	0	0	0	0	0	0	0	0	0	0	0	0	
4:15 PM	0	0	0	0	0	0	0	0	1	0	0	0	0	0	0	0	1	
4:30 PM	0	0	0	0	0	0	0	0	3	0	0	0	0	0	0	0	3	
4:45 PM	0	0	1	0	0	0	0	0	2	0	0	0	0	0	0	0	3	
5:00 PM	0	0	0	0	0	0	0	0	0	0	0	0	0	0	0	0	0	
5:15 PM	0	0	0	0	0	0	0	0	0	0	0	0	0	0	0	0	0	
5:30 PM	0	0	0	0	0	0	0	0	0	0	0	0	0	1	0	0	1	
5:45 PM	0	0	0	0	0	0	0	0	0	0	0	0	0	0	0	0	0	
Count Total	0	0	1	0	0	0	0	0	6	0	0	0	0	0	1	0	8	
Peak Hour	0	0	1	0	0	0	0	0	5	0	0	0	0	0	0	0	6	
Two-Hour Count Summaries - Bikes																		
Interval Start	N 117th St			1st Ave NE			1st Ave NE			1st Ave NE			15-min Total	Rolling One Hour				
	Eastbound			Westbound			Northbound			Southbound								
	LT	TH	RT	LT	TH	RT	LT	TH	RT	LT	TH	RT						
4:00 PM	0	0	0	0	1	0	0	0	0	0	0	0	0	0	1	0		
4:15 PM	0	0	0	0	0	0	0	0	0	0	0	1	0	0	1	0		
4:30 PM	0	0	0	0	0	0	0	0	0	0	0	0	0	0	0	0		
4:45 PM	0	0	0	0	0	0	1	0	0	0	0	2	0	0	3	5		
5:00 PM	0	0	0	0	0	0	0	0	0	0	0	0	0	0	0	4		
5:15 PM	0	0	0	0	0	0	0	0	0	0	0	0	0	0	0	3		
5:30 PM	0	0	0	0	0	0	0	0	0	0	0	0	0	0	0	3		
5:45 PM	0	0	0	0	0	0	0	1	0	0	0	0	0	0	1	1		
Count Total	0	0	0	0	1	1	1	1	0	0	0	3	0	0	6	0		
Peak Hour	0	0	0	0	0	0	1	0	0	0	2	0	0	3	0	0		
<i>Note: U-Turn volumes for bikes are included in Left-Turn, if any.</i>																		

Aurora Ave N N 125th St



Peak Hour

Date: 07/18/2023
Count Period: 7:00 AM to 9:00 AM
Peak Hour: 8:00 AM to 9:00 AM

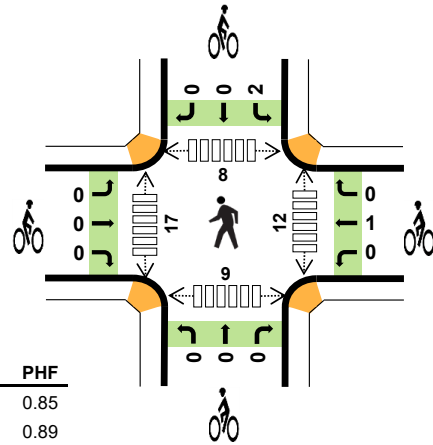
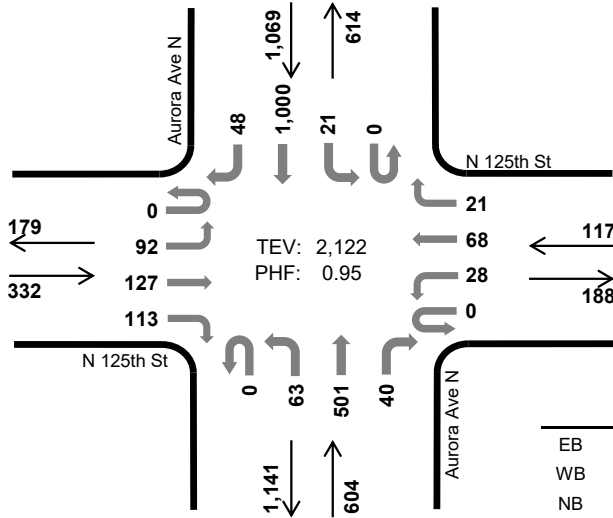

	HV %:	PHF
EB	2.7%	0.85
WB	4.3%	0.89
NB	10.1%	0.85
SB	6.4%	0.90
TOTAL	6.7%	0.95

Two-Hour Count Summaries

Interval Start	N 125th St Eastbound				N 125th St Westbound				Aurora Ave N Northbound				Aurora Ave N Southbound				15-min Total	Rolling One Hour	
	UT	LT	TH	RT	UT	LT	TH	RT	UT	LT	TH	RT	UT	LT	TH	RT			
7:00 AM	0	6	20	10	0	7	9	5	2	15	59	4	0	4	183	9	333	0	
7:15 AM	0	13	22	14	0	6	6	2	0	8	88	7	0	6	251	13	436	0	
7:30 AM	0	12	31	26	0	8	20	3	1	17	108	8	0	5	240	15	494	0	
7:45 AM	0	16	22	28	0	9	17	3	0	10	142	5	0	6	237	9	504	1,767	
8:00 AM	0	22	31	24	0	7	14	9	0	14	107	8	0	1	227	10	474	1,908	
8:15 AM	0	19	28	33	0	9	23	1	0	11	125	13	0	6	279	11	558	2,030	
8:30 AM	0	28	36	34	0	3	17	3	0	21	120	7	0	12	241	11	533	2,069	
8:45 AM	0	23	32	22	0	9	14	8	0	17	149	12	0	2	253	16	557	2,122	
Count Total	0	139	222	191	0	58	120	34	3	113	898	64	0	42	1,911	94	3,889	0	
Peak Hour	All	0	92	127	113	0	28	68	21	0	63	501	40	0	21	1,000	48	2,122	0
	HV	0	3	1	5	0	1	4	0	0	7	48	6	0	0	67	1	143	0
	HV%	-	3%	1%	4%	-	4%	6%	0%	-	11%	10%	15%	-	0%	7%	2%	7%	0

Note: Two-hour count summary volumes include heavy vehicles but exclude bicycles in overall count.

Interval Start	Heavy Vehicle Totals					Bicycles					Pedestrians (Crossing Leg)				
	EB	WB	NB	SB	Total	EB	WB	NB	SB	Total	East	West	North	South	Total
7:00 AM	0	1	5	9	15	0	0	0	0	0	6	2	0	2	10
7:15 AM	2	0	13	24	39	0	0	0	0	0	1	1	2	1	5
7:30 AM	1	6	12	14	33	0	0	0	0	0	0	6	0	2	8
7:45 AM	2	3	10	19	34	0	0	0	0	0	1	7	1	4	13
8:00 AM	3	0	17	22	42	0	0	0	1	1	4	5	4	3	16
8:15 AM	3	2	12	20	37	0	1	0	0	1	2	4	2	1	9
8:30 AM	2	1	17	12	32	0	0	0	0	0	4	2	1	0	7
8:45 AM	1	2	15	14	32	0	0	0	1	1	2	6	1	5	14
Count Total	14	15	101	134	264	0	1	0	2	3	20	33	11	18	82
Peak Hour	9	5	61	68	143	0	1	0	2	3	12	17	8	9	46

Two-Hour Count Summaries - Heavy Vehicles																		
Interval Start	N 125th St				N 125th St				Aurora Ave N				Aurora Ave N				15-min Total	Rolling One Hour
	Eastbound				Westbound				Northbound				Southbound					
	UT	LT	TH	RT	UT	LT	TH	RT	UT	LT	TH	RT	UT	LT	TH	RT		
7:00 AM	0	0	0	0	0	1	0	0	0	1	4	0	0	0	9	0	15	0
7:15 AM	0	0	0	2	0	0	0	0	0	1	10	2	0	2	22	0	39	0
7:30 AM	0	0	0	1	0	2	4	0	0	0	9	3	0	0	13	1	33	0
7:45 AM	0	1	0	1	0	1	2	0	0	0	10	0	0	0	18	1	34	121
8:00 AM	0	1	0	2	0	0	0	0	0	2	13	2	0	0	22	0	42	148
8:15 AM	0	1	1	1	0	0	2	0	0	3	8	1	0	0	19	1	37	146
8:30 AM	0	1	0	1	0	0	1	0	0	2	14	1	0	0	12	0	32	145
8:45 AM	0	0	0	1	0	1	1	0	0	0	13	2	0	0	14	0	32	143
Count Total	0	4	1	9	0	5	10	0	0	9	81	11	0	2	129	3	264	0
Peak Hour	0	3	1	5	0	1	4	0	0	7	48	6	0	0	67	1	143	0
Two-Hour Count Summaries - Bikes																		
Interval Start	N 125th St			N 125th St			Aurora Ave N			Aurora Ave N			15-min Total	Rolling One Hour				
	Eastbound			Westbound			Northbound			Southbound								
	LT	TH	RT	LT	TH	RT	LT	TH	RT	LT	TH	RT						
7:00 AM	0	0	0	0	0	0	0	0	0	0	0	0	0	0	0	0	0	0
7:15 AM	0	0	0	0	0	0	0	0	0	0	0	0	0	0	0	0	0	0
7:30 AM	0	0	0	0	0	0	0	0	0	0	0	0	0	0	0	0	0	0
7:45 AM	0	0	0	0	0	0	0	0	0	0	0	0	0	0	0	0	0	0
8:00 AM	0	0	0	0	0	0	0	0	0	0	0	0	1	0	0	1	1	1
8:15 AM	0	0	0	0	0	1	0	0	0	0	0	0	0	0	0	1	2	2
8:30 AM	0	0	0	0	0	0	0	0	0	0	0	0	0	0	0	0	0	2
8:45 AM	0	0	0	0	0	0	0	0	0	0	0	0	1	0	0	1	3	3
Count Total	0	0	0	0	0	1	0	0	0	0	0	0	2	0	0	3	0	0
Peak Hour	0	0	0	0	0	1	0	0	0	0	0	0	2	0	0	3	0	0
<i>Note: U-Turn volumes for bikes are included in Left-Turn, if any.</i>																		

Aurora Ave N N 125th St



Peak Hour

Date: 07/18/2023
Count Period: 4:00 PM to 6:00 PM
Peak Hour: 4:00 PM to 5:00 PM

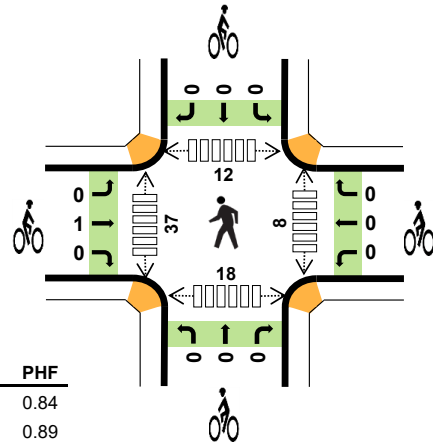
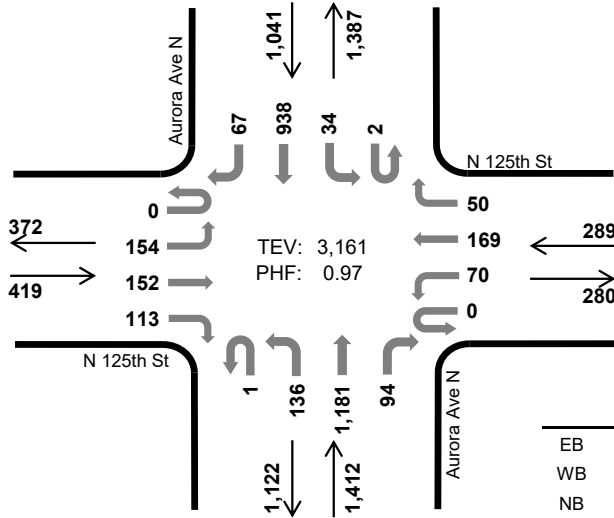

	HV %:	PHF
EB	2.1%	0.84
WB	2.1%	0.89
NB	3.3%	0.94
SB	5.0%	0.94
TOTAL	3.6%	0.97

Two-Hour Count Summaries

Interval Start	N 125th St Eastbound				N 125th St Westbound				Aurora Ave N Northbound				Aurora Ave N Southbound				15-min Total	Rolling One Hour	
	UT	LT	TH	RT	UT	LT	TH	RT	UT	LT	TH	RT	UT	LT	TH	RT			
4:00 PM	0	38	34	31	0	28	39	11	1	32	308	27	0	6	242	18	815	0	
4:15 PM	0	36	35	33	0	16	50	15	0	38	270	20	2	13	237	17	782	0	
4:30 PM	0	30	34	23	0	16	38	14	0	36	319	21	0	7	254	15	807	0	
4:45 PM	0	50	49	26	0	10	42	10	0	30	284	26	0	8	205	17	757	3,161	
5:00 PM	0	29	26	21	0	12	43	15	1	33	321	30	0	9	237	16	793	3,139	
5:15 PM	0	34	35	29	0	22	50	16	0	40	281	24	0	15	216	14	776	3,133	
5:30 PM	0	21	23	21	0	17	41	13	1	28	298	19	0	11	262	18	773	3,099	
5:45 PM	0	34	36	10	0	25	46	18	0	28	323	14	0	5	251	19	809	3,151	
Count Total	0	272	272	194	0	146	349	112	3	265	2,404	181	2	74	1,904	134	6,312	0	
Peak Hour	All	0	154	152	113	0	70	169	50	1	136	1,181	94	2	34	938	67	3,161	0
	HV	0	4	0	5	0	2	1	3	0	7	36	3	0	1	48	3	113	0
	HV%	-	3%	0%	4%	-	3%	1%	6%	0%	5%	3%	3%	0%	3%	5%	4%	4%	0

Note: Two-hour count summary volumes include heavy vehicles but exclude bicycles in overall count.

Interval Start	Heavy Vehicle Totals					Bicycles					Pedestrians (Crossing Leg)				
	EB	WB	NB	SB	Total	EB	WB	NB	SB	Total	East	West	North	South	Total
4:00 PM	4	2	13	10	29	0	0	0	0	0	3	8	2	4	17
4:15 PM	0	2	10	24	36	0	0	0	0	0	1	4	1	4	10
4:30 PM	4	0	10	9	23	1	0	0	0	1	2	12	2	4	20
4:45 PM	1	2	13	9	25	0	0	0	0	0	2	13	7	6	28
5:00 PM	2	0	9	9	20	1	0	0	0	1	4	7	8	2	21
5:15 PM	3	0	11	4	18	0	0	0	0	0	4	14	2	3	23
5:30 PM	2	0	9	8	19	1	1	0	0	2	4	17	4	8	33
5:45 PM	1	1	7	7	16	0	0	0	0	0	0	10	2	6	18
Count Total	17	7	82	80	186	3	1	0	0	4	20	85	28	37	170
Peak Hour	9	6	46	52	113	1	0	0	0	1	8	37	12	18	75

Two-Hour Count Summaries - Heavy Vehicles																		
Interval Start	N 125th St				N 125th St				Aurora Ave N				Aurora Ave N				15-min Total	Rolling One Hour
	Eastbound				Westbound				Northbound				Southbound					
	UT	LT	TH	RT	UT	LT	TH	RT	UT	LT	TH	RT	UT	LT	TH	RT		
4:00 PM	0	3	0	1	0	1	1	0	0	3	9	1	0	0	9	1	29	0
4:15 PM	0	0	0	0	0	1	0	1	0	0	10	0	0	1	23	0	36	0
4:30 PM	0	0	0	4	0	0	0	0	0	2	7	1	0	0	9	0	23	0
4:45 PM	0	1	0	0	0	0	0	2	0	2	10	1	0	0	7	2	25	113
5:00 PM	0	2	0	0	0	0	0	0	0	0	9	0	0	0	8	1	20	104
5:15 PM	0	2	1	0	0	0	0	0	0	0	10	1	0	0	4	0	18	86
5:30 PM	0	0	1	1	0	0	0	0	0	1	8	0	0	0	7	1	19	82
5:45 PM	0	1	0	0	0	1	0	0	0	0	7	0	0	0	7	0	16	73
Count Total	0	9	2	6	0	3	1	3	0	8	70	4	0	1	74	5	186	0
Peak Hour	0	4	0	5	0	2	1	3	0	7	36	3	0	1	48	3	113	0
Two-Hour Count Summaries - Bikes																		
Interval Start	N 125th St			N 125th St			Aurora Ave N			Aurora Ave N			15-min Total	Rolling One Hour				
	Eastbound			Westbound			Northbound			Southbound								
	LT	TH	RT	LT	TH	RT	LT	TH	RT	LT	TH	RT						
4:00 PM	0	0	0	0	0	0	0	0	0	0	0	0	0	0	0	0	0	0
4:15 PM	0	0	0	0	0	0	0	0	0	0	0	0	0	0	0	0	0	0
4:30 PM	0	1	0	0	0	0	0	0	0	0	0	0	0	0	0	0	1	0
4:45 PM	0	0	0	0	0	0	0	0	0	0	0	0	0	0	0	0	0	1
5:00 PM	0	1	0	0	0	0	0	0	0	0	0	0	0	0	0	0	1	2
5:15 PM	0	0	0	0	0	0	0	0	0	0	0	0	0	0	0	0	0	2
5:30 PM	0	1	0	0	0	1	0	0	0	0	0	0	0	0	0	0	2	3
5:45 PM	0	0	0	0	0	0	0	0	0	0	0	0	0	0	0	0	0	3
Count Total	0	3	0	0	0	1	0	0	0	0	0	0	0	0	0	0	4	0
Peak Hour	0	1	0	0	0	0	0	0	0	0	0	0	0	0	0	0	1	0
<i>Note: U-Turn volumes for bikes are included in Left-Turn, if any.</i>																		

Appendix B Detailed Trip Generation

UW Medical Center - MIMP
Trip Generation Summary

2022 Existing Counts

Day	AM Peak Hour Vehicle Count			PM Peak Hour Vehicle Count		
	In	Out	Total	In	Out	Total
10-May	389	189	578	92	354	446
11-May	365	178	543	74	327	401
(A) Existing Driveway Trips:	377	184	561	83	341	424
Trips on 115th (Calibrated)	30	15	45	30	62	92
Total	407	199	606	113	403	516
Existing Rate (Trips/1,000 sf):			1.10	0.94		
% In			67%	22%		

Trips assumed off-site

No Action Trip Generation -

(B) Net New Trips	AM Peak Hour Vehicle Trips			PM Peak Hour Vehicle Trips			
	In	Out	Total	In	Out	Total	
BHTF	188,846	76	44	120	-6	79	73
Hospital	26,000	19	10	29	5	19	24
Baseline Total	214,846	95	54	149	-1	98	97
NO ACTION (C = A + B) No Action Trips:	502	253	755	112	501	613	

All trips added to DW

RIGHT SIZE

	AM Peak Hour Vehicle Trips			PM Peak Hour Vehicle Trips		
	In	Out	Total	In	Out	Total
(A) Existing Trips:	407	199	606	113	403	516
CALIBRATED Rate for RIGHT SIZING (trips/1,000 sf): <i>Existing trips/Right sized</i>	0.79			0.67		

MIMP

+ 835,457 sf

MIMP TOTAL: 1,600,000

Trip Generation of
MIMP Additional Growth

(D) MIMP New Trips	AM Peak Hour Vehicle Trips			PM Peak Hour Vehicle Trips			sf
	In	Out	Total	In	Out	Total	
<i>Interim (2030)</i>	445	217	662	123	440	563	835,457
	425	208	633	118	421	539	800,000

Estimated per CALIBRATED Rate for RIGHT SIZING (trips/1,000 sf)

Cumulative Total Trip Generation

		AM Peak Hour	PM Peak Hour	Size
Existing	A	606	516	549,697
No Action	C (A + B)	755	613	764,543
MIMP	C + D	1,417	1,176	1,600,000
MIMP Net New Trips		662	563	835,457

Existing CTR Affected Employees 1,000,000
 Rate of CTR Affected Employees per 1,000 SF 2832861.19

Increase in CTR Affected Employees 424929

Existing TMP Summary (Nov 2019 CTR)		Future TMP Summary, SOV Shift to Target SOV (65%)		Future TMP Summary, SOV Shift to Target SOV (50%)	
CTR Affected Employees		CTR Affected Employees		CTR Affected Employees	
Employees	1,000,000	Employees	100,000	Employees	100,000
<i>Employee Mode Split</i>					
SOV	74.7%	SOV (Target)	65.0%	SOV (Sensitivity)	50.0%
Non-SOV	25.3%	Non-SOV	35.0%	Non-SOV	50.0%
Carpool	8.6%	Carpool (Estimated)	11.9%	Carpool (Estimated)	17.0%
Vanpool	5.0%	Vanpool (Estimated)	6.9%	Vanpool (Estimated)	9.9%
Walk	1.5%	Walk (Estimated)	2.1%	Walk (Estimated)	3.0%
Bike	0.8%	Bike (Estimated)	1.1%	Bike (Estimated)	1.6%
Transit	7.4%	Transit (Estimated)	10.2%	Transit (Estimated)	14.6%
Telework	0.5%	Telework (Estimated)	0.7%	Telework (Estimated)	1.0%
Other	1.7%	Other (Estimated)	2.3%	Other (Estimated)	3.3%
AVO	1.11	AVO	1.17	AVO	1.28
SOV	1	SOV	1	SOV	1
Carpool	2.12	Carpool	2.12	Carpool	2.12
Vanpool	5.44	Vanpool	5.44	Vanpool	5.44

Walk/Bike	2.5%	3.0%	4.5%
Transit	7%	10%	15%
Other	1.5%	3.0%	3.5%
Vehicle	89%	84%	77%
Total			

UWMC NW - 75% SOV

Person Trips by Mode of Travel

Trip Generation Summary	Percent By Mode	AM Peak Hour			PM Peak Hour		
		In	Out	Total	In	Out	Total
<u>Alternative 1 (Subtotal)</u>							
MIMP Additional Growth							
Walk, Bike, Other Trips	2.5%	14	7	21	4	14	18
Transit Trips	7%	39	19	58	11	38	49
Other	1.5%	8	4	12	2	8	11
Person Trips by Vehicle	89%	<u>493</u>	<u>240</u>	<u>734</u>	<u>136</u>	<u>488</u>	<u>624</u>
Total	100%	554	270	824	153	548	701
<u>No Action (Subtotal)</u>							
UWMC							
Walk, Bike, Other Trips	3%	3	2	5	0	3	3
Transit Trips	7%	8	5	13	0	8	8
Other	2%	2	0	2	0	2	2
Person Trips by Vehicle	89%	<u>105</u>	<u>60</u>	<u>165</u>	<u>-1</u>	<u>108</u>	<u>107</u>
Total	100%	118	67	185	-1	121	120
<u>Existing Use</u>							
UWMC							
Walk, Bike, Other Trips	2.5%	13	6	19	4	13	16
Transit Trips	7%	35	17	53	10	35	45
Other	1.5%	8	4	11	1	8	10
Person Trips by Vehicle	89%	<u>451</u>	<u>220</u>	<u>671</u>	<u>125</u>	<u>446</u>	<u>571</u>
Total	100%	507	247	754	140	502	642
<u>Alterantive 1 Total Project Person Trips</u>							
Walk, Bike, Other Trips		30	15	45	8	30	37
Transit Trips		82	41	124	21	81	102
Other		18	8	25	3	18	23
Person Trips by Vehicle		1,049	520	1,570	260	1,042	1,302
Total		1,179	584	1,763	292	1,171	1,463

Vehicle Trip Generation

Land Use	AVO	AM Peak Hour Vehicle Trips			PM Peak Hour Vehicle Trips		
		In	Out	Total	In	Out	Total
Added with MIMP	1.11	445	217	662	123	440	563
Baseline	1.11	95	54	149	-1	98	97
Existing Use	1.11	407	199	606	113	403	516
Total Vehicle Trips		947	470	1,417	235	941	1,176

UWMC NW - 65% SOV

Person Trips by Mode of Travel

Trip Generation Summary	Percent By Mode	AM Peak Hour			PM Peak Hour		
		In	Out	Total	In	Out	Total
<u>Alternative 1 (Subtotal)</u>							
MIMP Additional Growth							
Walk, Bike, Other Trips	3.0%	17	8	25	5	16	21
Transit Trips	10%	55	27	82	15	55	70
Other	3.0%	17	8	25	5	16	21
Person Trips by Vehicle	84%	<u>465</u>	<u>226</u>	<u>691</u>	<u>128</u>	<u>462</u>	<u>590</u>
Total	100%	554	270	824	153	548	701
<u>No Action (Subtotal)</u>							
UWMC							
Walk, Bike, Other Trips	3%	4	2	6	0	4	4
Transit Trips	10%	12	7	19	0	12	12
Other	3%	4	2	6	0	4	4
Person Trips by Vehicle	84%	<u>99</u>	<u>56</u>	<u>155</u>	<u>-1</u>	<u>102</u>	<u>101</u>
Total	100%	118	67	185	-1	121	120
<u>Existing Use</u>							
UWMC							
Walk, Bike, Other Trips	3.0%	15	7	23	4	15	19
Transit Trips	10%	51	25	75	14	50	64
Other	3.0%	15	7	23	4	15	19
Person Trips by Vehicle	84%	<u>426</u>	<u>208</u>	<u>633</u>	<u>118</u>	<u>422</u>	<u>540</u>
Total	100%	507	247	754	140	502	642
<u>Alterantive 1 Total Project Person Trips</u>							
<i>Walk, Bike, Other Trips</i>		36	17	53	9	35	44
<i>Transit Trips</i>		118	59	176	29	117	146
<i>Other</i>		36	17	53	9	35	44
<i>Person Trips by Vehicle</i>		990	490	1,480	245	986	1,231
<i>Total</i>		1,179	584	1,763	292	1,171	1,463

Vehicle Trip Generation

Land Use	AVO	AM Peak Hour Vehicle Trips			PM Peak Hour Vehicle Trips		
		In	Out	Total	In	Out	Total
Added with MIMP	1.17	399	194	593	110	396	506
Baseline	1.17	93	53	146	-1	96	95
Existing Use	1.17	365	178	543	101	362	463
Total Vehicle Trips		857	425	1,282	210	854	1,064

UWMC NW - 50% SOV

Person Trips by Mode of Travel

Trip Generation Summary	Percent By Mode	AM Peak Hour			PM Peak Hour		
		In	Out	Total	In	Out	Total
<u>Alternative 1 (Subtotal)</u>							
MIMP Additional Growth							
Walk, Bike, Other Trips	4.5%	25	12	37	7	25	32
Transit Trips	15%	83	40	124	23	82	105
Other	3.5%	20	9	29	5	19	25
Person Trips by Vehicle	77%	<u>427</u>	<u>208</u>	<u>635</u>	<u>118</u>	<u>423</u>	<u>541</u>
Total	100%	555	269	824	154	547	701
<u>No Action (Subtotal)</u>							
UWMC							
Walk, Bike, Other Trips	5%	5	3	8	0	5	5
Transit Trips	15%	18	10	28	0	18	18
Other	3%	4	2	6	0	4	4
Person Trips by Vehicle	77%	<u>91</u>	<u>52</u>	<u>142</u>	<u>-1</u>	<u>93</u>	<u>92</u>
Total	100%	118	67	185	-1	121	120
<u>Existing Use</u>							
UWMC							
Walk, Bike, Other Trips	4.5%	23	11	34	6	23	29
Transit Trips	15%	76	37	113	21	75	96
Other	3.5%	18	8	26	5	17	22
Person Trips by Vehicle	77%	<u>391</u>	<u>190</u>	<u>581</u>	<u>108</u>	<u>387</u>	<u>495</u>
Total	100%	508	246	754	140	502	642
<u>Alterantive 1 Total Project Person Trips</u>							
<i>Walk, Bike, Other Trips</i>		53	26	79	13	53	66
<i>Transit Trips</i>		177	87	264	44	175	219
<i>Other</i>		42	20	61	10	40	51
<i>Person Trips by Vehicle</i>		909	450	1,358	225	903	1,128
<i>Total</i>		1,181	582	1,763	293	1,170	1,463

Vehicle Trip Generation

Land Use	AVO	AM Peak Hour Vehicle Trips			PM Peak Hour Vehicle Trips		
		In	Out	Total	In	Out	Total
Added with MIMP	1.28	332	162	494	92	329	421
Baseline	1.28	90	51	141	-2	93	91
Existing Use	1.28	304	148	452	84	301	385
Total Vehicle Trips		726	361	1,087	174	723	897

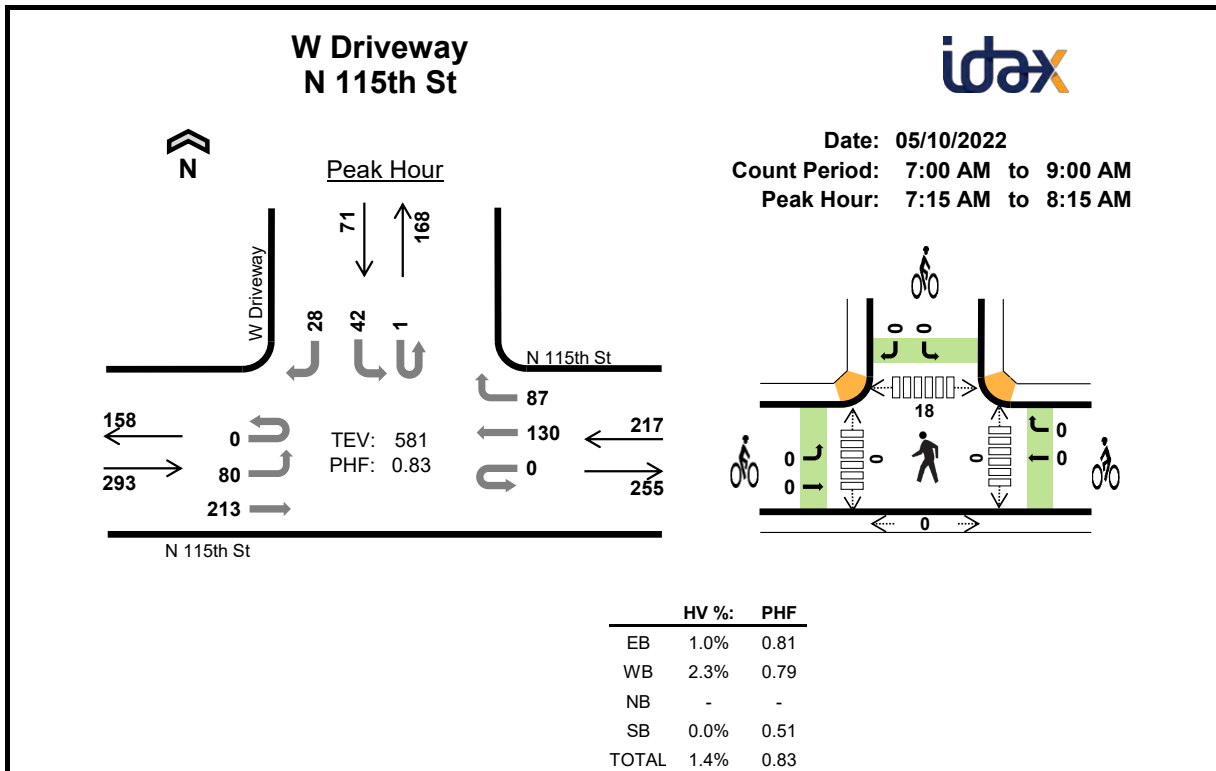

Two-Hour Count Summaries

Interval Start	N 115th St Eastbound				N 115th St Westbound				0 Northbound				W Driveway Southbound				15-min Total	Rolling One Hour	
	UT	LT	TH	RT	UT	LT	TH	RT	UT	LT	TH	RT	UT	LT	TH	RT			
	7:00 AM	0	13	29	0	0	0	25	25	0	0	0	0	0	3	0			0
7:15 AM	0	18	41	0	0	0	21	30	0	0	0	0	1	10	0	3	124	0	
7:30 AM	0	21	56	0	0	0	31	16	0	0	0	0	0	20	0	15	159	0	
7:45 AM	0	26	64	0	0	0	42	27	0	0	0	0	0	9	0	8	176	554	
8:00 AM	0	15	52	0	0	0	36	14	0	0	0	0	0	3	0	2	122	581	
8:15 AM	0	17	41	0	0	0	31	22	0	0	0	0	0	6	0	0	117	574	
8:30 AM	0	11	53	0	1	0	42	10	0	0	0	0	0	5	0	1	123	538	
8:45 AM	0	12	42	0	0	0	42	11	0	0	0	0	0	1	0	2	110	472	
Count Total	0	133	378	0	1	0	270	155	0	0	0	0	1	57	0	31	1,026	0	
Peak Hour	All	0	80	213	0	0	0	130	87	0	0	0	0	1	42	0	28	581	0
	HV	0	1	2	0	0	0	5	0	0	0	0	0	0	0	0	0	8	0
	HV%	-	1%	1%	-	-	-	4%	0%	-	-	-	-	0%	0%	-	0%	1%	0

Note: Two-hour count summary volumes include heavy vehicles but exclude bicycles in overall count.

Interval Start	Heavy Vehicle Totals					Bicycles					Pedestrians (Crossing Leg)				
	EB	WB	NB	SB	Total	EB	WB	NB	SB	Total	East	West	North	South	Total
7:00 AM	1	2	0	0	3	1	0	0	0	1	0	0	1	0	1
7:15 AM	0	1	0	0	1	0	0	0	0	0	0	0	2	0	2
7:30 AM	1	0	0	0	1	0	0	0	0	0	0	0	3	0	3
7:45 AM	0	1	0	0	1	0	0	0	0	0	0	0	4	0	4
8:00 AM	2	3	0	0	5	0	0	0	0	0	0	0	9	0	9
8:15 AM	3	4	0	0	7	0	0	0	0	0	0	0	3	0	3
8:30 AM	3	2	0	0	5	0	0	0	0	0	0	0	2	0	2
8:45 AM	1	2	0	0	3	0	0	0	0	0	0	0	5	0	5
Count Total	11	15	0	0	26	1	0	0	0	1	0	0	29	0	29
Peak Hr	3	5	0	0	8	0	0	0	0	0	0	0	18	0	18

Two-Hour Count Summaries - Heavy Vehicles																		
Interval Start	N 115th St				N 115th St				0				W Driveway				15-min Total	Rolling One Hour
	Eastbound				Westbound				Northbound				Southbound					
	UT	LT	TH	RT	UT	LT	TH	RT	UT	LT	TH	RT	UT	LT	TH	RT		
7:00 AM	0	0	1	0	0	0	2	0	0	0	0	0	0	0	0	3	0	
7:15 AM	0	0	0	0	0	0	1	0	0	0	0	0	0	0	0	1	0	
7:30 AM	0	1	0	0	0	0	0	0	0	0	0	0	0	0	0	1	0	
7:45 AM	0	0	0	0	0	0	1	0	0	0	0	0	0	0	0	1	6	
8:00 AM	0	0	2	0	0	0	3	0	0	0	0	0	0	0	0	5	8	
8:15 AM	0	0	3	0	0	0	4	0	0	0	0	0	0	0	0	7	14	
8:30 AM	0	0	3	0	0	0	2	0	0	0	0	0	0	0	0	5	18	
8:45 AM	0	0	1	0	0	0	2	0	0	0	0	0	0	0	0	3	20	
Count Total	0	1	10	0	0	0	15	0	0	0	0	0	0	0	0	26	0	
Peak Hour	0	1	2	0	0	0	5	0	0	0	0	0	0	0	0	8	0	

Two-Hour Count Summaries - Bikes														
Interval Start	N 115th St			N 115th St			0			W Driveway			15-min Total	Rolling One Hour
	Eastbound			Westbound			Northbound			Southbound				
	LT	TH	RT	LT	TH	RT	LT	TH	RT	LT	TH	RT		
7:00 AM	0	1	0	0	0	0	0	0	0	0	0	0	1	0
7:15 AM	0	0	0	0	0	0	0	0	0	0	0	0	0	0
7:30 AM	0	0	0	0	0	0	0	0	0	0	0	0	0	0
7:45 AM	0	0	0	0	0	0	0	0	0	0	0	0	0	1
8:00 AM	0	0	0	0	0	0	0	0	0	0	0	0	0	0
8:15 AM	0	0	0	0	0	0	0	0	0	0	0	0	0	0
8:30 AM	0	0	0	0	0	0	0	0	0	0	0	0	0	0
8:45 AM	0	0	0	0	0	0	0	0	0	0	0	0	0	0
Count Total	0	1	0	0	0	0	0	0	0	0	0	0	1	0
Peak Hour	0	0	0	0	0	0	0	0	0	0	0	0	0	0

Note: U-Turn volumes for bikes are included in Left-Turn, if any.

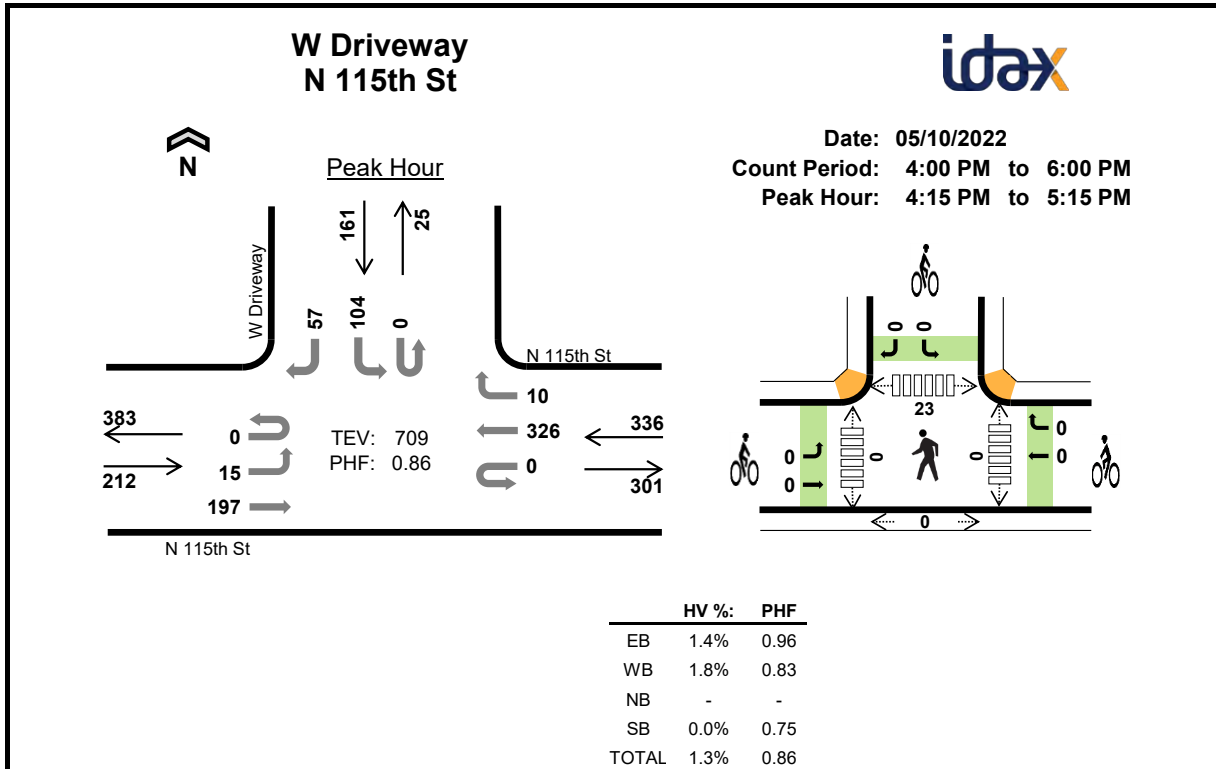

Two-Hour Count Summaries

Interval Start	N 115th St Eastbound				N 115th St Westbound				0 Northbound				W Driveway Southbound				15-min Total	Rolling One Hour	
	UT	LT	TH	RT	UT	LT	TH	RT	UT	LT	TH	RT	UT	LT	TH	RT			
4:00 PM	0	0	39	0	1	0	93	1	0	0	0	0	0	20	0	11	165	0	
4:15 PM	0	3	51	0	0	0	84	4	0	0	0	0	0	17	0	9	168	0	
4:30 PM	0	0	50	0	0	0	97	4	0	0	0	0	0	35	0	19	205	0	
4:45 PM	0	4	51	0	0	0	63	1	0	0	0	0	0	27	0	11	157	695	
5:00 PM	0	8	45	0	0	0	82	1	0	0	0	0	0	25	0	18	179	709	
5:15 PM	0	1	35	0	0	0	67	2	0	0	0	0	0	20	0	20	145	686	
5:30 PM	0	0	50	0	1	0	72	4	0	0	0	0	0	40	0	12	179	660	
5:45 PM	0	2	48	0	0	0	66	4	0	0	0	0	0	14	0	16	150	653	
Count Total	0	18	369	0	2	0	624	21	0	0	0	0	0	198	0	116	1,348	0	
Peak Hour	All	0	15	197	0	0	0	326	10	0	0	0	0	0	104	0	57	709	0
	HV	0	0	3	0	0	0	6	0	0	0	0	0	0	0	0	0	9	0
	HV%	-	0%	2%	-	-	-	2%	0%	-	-	-	-	-	0%	-	0%	1%	0

Note: Two-hour count summary volumes include heavy vehicles but exclude bicycles in overall count.

Interval Start	Heavy Vehicle Totals					Bicycles					Pedestrians (Crossing Leg)				
	EB	WB	NB	SB	Total	EB	WB	NB	SB	Total	East	West	North	South	Total
4:00 PM	1	3	0	0	4	0	0	0	0	0	0	0	5	0	5
4:15 PM	2	2	0	0	4	0	0	0	0	0	0	0	4	0	4
4:30 PM	1	2	0	0	3	0	0	0	0	0	0	0	6	0	6
4:45 PM	0	1	0	0	1	0	0	0	0	0	0	0	7	0	7
5:00 PM	0	1	0	0	1	0	0	0	0	0	0	0	6	0	6
5:15 PM	0	1	0	0	1	0	0	0	0	0	0	0	5	0	5
5:30 PM	0	0	0	0	0	0	0	0	0	0	0	0	11	0	11
5:45 PM	0	3	0	0	3	0	0	0	0	0	0	0	5	0	5
Count Total	4	13	0	0	17	0	0	0	0	0	0	0	49	0	49
Peak Hr	3	6	0	0	9	0	0	0	0	0	0	0	23	0	23

Two-Hour Count Summaries - Heavy Vehicles														15-min Total	Rolling One Hour			
Interval Start	N 115th St				N 115th St				0				W Driveway					
	Eastbound				Westbound				Northbound				Southbound					
	UT	LT	TH	RT	UT	LT	TH	RT	UT	LT	TH	RT	UT	LT	TH	RT		
4:00 PM	0	0	1	0	0	0	3	0	0	0	0	0	0	0	0	0	4	0
4:15 PM	0	0	2	0	0	0	2	0	0	0	0	0	0	0	0	0	4	0
4:30 PM	0	0	1	0	0	0	2	0	0	0	0	0	0	0	0	0	3	0
4:45 PM	0	0	0	0	0	0	1	0	0	0	0	0	0	0	0	0	1	12
5:00 PM	0	0	0	0	0	0	1	0	0	0	0	0	0	0	0	0	1	9
5:15 PM	0	0	0	0	0	0	1	0	0	0	0	0	0	0	0	0	1	6
5:30 PM	0	0	0	0	0	0	0	0	0	0	0	0	0	0	0	0	0	3
5:45 PM	0	0	0	0	0	0	3	0	0	0	0	0	0	0	0	0	3	5
Count Total	0	0	4	0	0	0	13	0	0	0	0	0	0	0	0	0	17	0
Peak Hour	0	0	3	0	0	0	6	0	0	0	0	0	0	0	0	0	9	0

Two-Hour Count Summaries - Bikes														15-min Total	Rolling One Hour			
Interval Start	N 115th St			N 115th St			0			W Driveway								
	Eastbound			Westbound			Northbound			Southbound								
	LT	TH	RT	LT	TH	RT	LT	TH	RT	LT	TH	RT						
4:00 PM	0	0	0	0	0	0	0	0	0	0	0	0	0	0	0	0	0	0
4:15 PM	0	0	0	0	0	0	0	0	0	0	0	0	0	0	0	0	0	0
4:30 PM	0	0	0	0	0	0	0	0	0	0	0	0	0	0	0	0	0	0
4:45 PM	0	0	0	0	0	0	0	0	0	0	0	0	0	0	0	0	0	0
5:00 PM	0	0	0	0	0	0	0	0	0	0	0	0	0	0	0	0	0	0
5:15 PM	0	0	0	0	0	0	0	0	0	0	0	0	0	0	0	0	0	0
5:30 PM	0	0	0	0	0	0	0	0	0	0	0	0	0	0	0	0	0	0
5:45 PM	0	0	0	0	0	0	0	0	0	0	0	0	0	0	0	0	0	0
Count Total	0	0	0	0	0	0	0	0	0	0	0	0	0	0	0	0	0	0
Peak Hour	0	0	0	0	0	0	0	0	0	0	0	0	0	0	0	0	0	0

Note: U-Turn volumes for bikes are included in Left-Turn, if any.

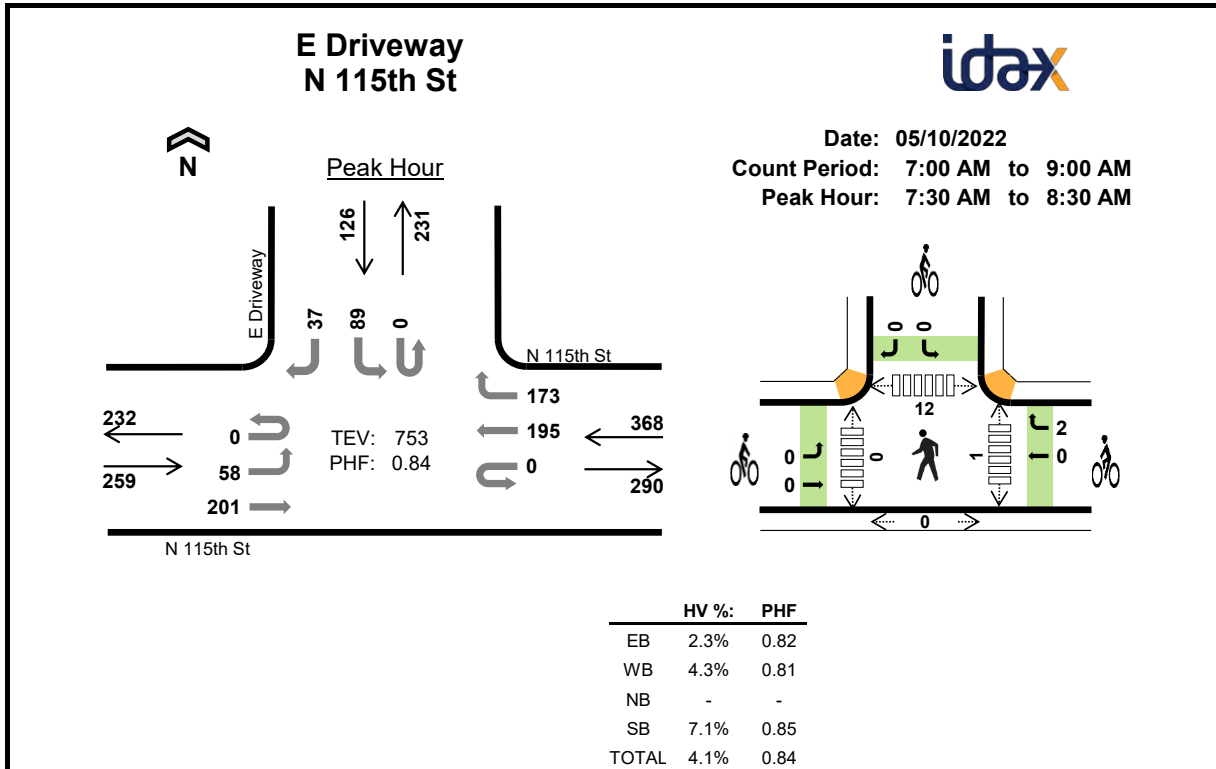

Two-Hour Count Summaries

Interval Start	N 115th St Eastbound				N 115th St Westbound				0 Northbound				E Driveway Southbound				15-min Total	Rolling One Hour	
	UT	LT	TH	RT	UT	LT	TH	RT	UT	LT	TH	RT	UT	LT	TH	RT			
	7:00 AM	0	10	23	0	0	0	46	46	0	0	0	0	0	11	0			8
7:15 AM	0	15	36	0	0	0	53	37	0	0	0	0	0	17	0	2	160	0	
7:30 AM	0	12	61	0	0	0	36	41	0	0	0	0	0	26	0	11	187	0	
7:45 AM	0	16	63	0	0	0	61	52	0	0	0	0	0	23	0	10	225	716	
8:00 AM	0	14	43	0	0	0	48	49	0	0	0	0	0	16	0	8	178	750	
8:15 AM	0	16	34	0	0	0	50	31	0	0	0	0	0	24	0	8	163	753	
8:30 AM	0	16	42	0	0	0	46	42	0	0	0	0	0	26	0	10	182	748	
8:45 AM	0	9	35	0	0	0	48	37	0	0	0	0	0	21	0	9	159	682	
Count Total	0	108	337	0	0	0	388	335	0	0	0	0	0	164	0	66	1,398	0	
Peak Hour	All	0	58	201	0	0	0	195	173	0	0	0	0	0	89	0	37	753	0
	HV	0	2	4	0	0	0	6	10	0	0	0	0	0	7	0	2	31	0
	HV%	-	3%	2%	-	-	-	3%	6%	-	-	-	-	-	8%	-	5%	4%	0

Note: Two-hour count summary volumes include heavy vehicles but exclude bicycles in overall count.

Interval Start	Heavy Vehicle Totals					Bicycles					Pedestrians (Crossing Leg)				
	EB	WB	NB	SB	Total	EB	WB	NB	SB	Total	East	West	North	South	Total
7:00 AM	1	2	0	3	6	0	0	0	0	0	1	0	2	0	3
7:15 AM	0	5	0	2	7	1	0	0	0	1	0	0	1	0	1
7:30 AM	0	3	0	0	3	0	0	0	0	0	0	0	1	0	1
7:45 AM	0	3	0	1	4	0	1	0	0	1	1	0	3	0	4
8:00 AM	3	6	0	2	11	0	0	0	0	0	0	0	5	0	5
8:15 AM	3	4	0	6	13	0	1	0	0	1	0	0	3	0	3
8:30 AM	3	3	0	2	8	0	0	0	0	0	1	0	2	0	3
8:45 AM	1	5	0	1	7	0	0	0	0	0	1	0	2	0	3
Count Total	11	31	0	17	59	1	2	0	0	3	4	0	19	0	23
Peak Hr	6	16	0	9	31	0	2	0	0	2	1	0	12	0	13

Two-Hour Count Summaries - Heavy Vehicles														15-min Total	Rolling One Hour			
Interval Start	N 115th St				N 115th St				0				E Driveway					
	Eastbound				Westbound				Northbound				Southbound					
	UT	LT	TH	RT	UT	LT	TH	RT	UT	LT	TH	RT	UT	LT	TH	RT		
7:00 AM	0	0	1	0	0	0	0	2	0	0	0	0	0	1	0	2	6	0
7:15 AM	0	0	0	0	0	0	2	3	0	0	0	0	0	2	0	0	7	0
7:30 AM	0	0	0	0	0	0	0	3	0	0	0	0	0	0	0	0	3	0
7:45 AM	0	0	0	0	0	0	1	2	0	0	0	0	0	1	0	0	4	20
8:00 AM	0	1	2	0	0	0	3	3	0	0	0	0	0	2	0	0	11	25
8:15 AM	0	1	2	0	0	0	2	2	0	0	0	0	0	4	0	2	13	31
8:30 AM	0	0	3	0	0	0	2	1	0	0	0	0	0	2	0	0	8	36
8:45 AM	0	1	0	0	0	0	2	3	0	0	0	0	0	1	0	0	7	39
Count Total	0	3	8	0	0	0	12	19	0	0	0	0	0	13	0	4	59	0
Peak Hour	0	2	4	0	0	0	6	10	0	0	0	0	0	7	0	2	31	0

Two-Hour Count Summaries - Bikes														15-min Total	Rolling One Hour			
Interval Start	N 115th St			N 115th St			0			E Driveway								
	Eastbound			Westbound			Northbound			Southbound								
	LT	TH	RT	LT	TH	RT	LT	TH	RT	LT	TH	RT						
7:00 AM	0	0	0	0	0	0	0	0	0	0	0	0	0	0	0	0	0	0
7:15 AM	1	0	0	0	0	0	0	0	0	0	0	0	0	0	0	0	1	0
7:30 AM	0	0	0	0	0	0	0	0	0	0	0	0	0	0	0	0	0	0
7:45 AM	0	0	0	0	0	0	1	0	0	0	0	0	0	0	0	0	1	2
8:00 AM	0	0	0	0	0	0	0	0	0	0	0	0	0	0	0	0	0	2
8:15 AM	0	0	0	0	0	0	1	0	0	0	0	0	0	0	0	0	1	2
8:30 AM	0	0	0	0	0	0	0	0	0	0	0	0	0	0	0	0	0	2
8:45 AM	0	0	0	0	0	0	0	0	0	0	0	0	0	0	0	0	0	1
Count Total	1	0	0	0	0	0	2	0	0	0	0	0	0	0	0	0	3	0
Peak Hour	0	0	0	0	0	0	2	0	0	0	0	0	0	0	0	0	2	0

Note: U-Turn volumes for bikes are included in Left-Turn, if any.

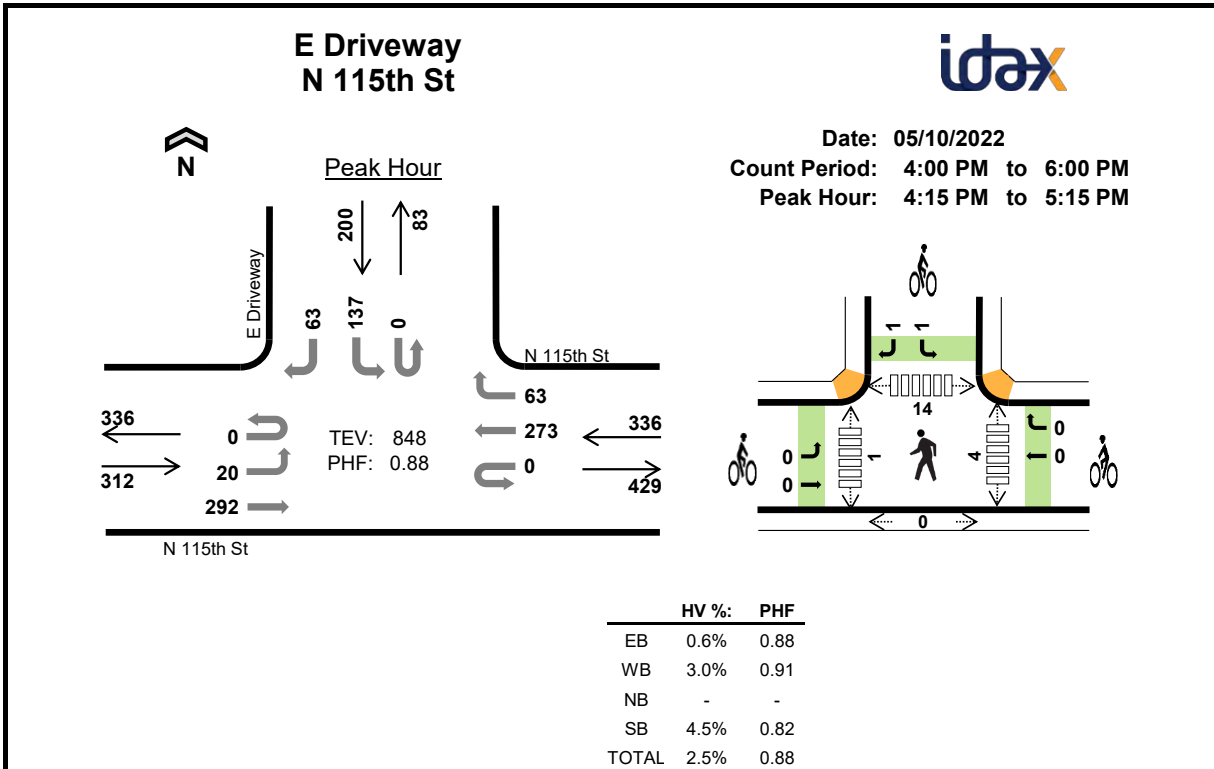

Two-Hour Count Summaries

Interval Start	N 115th St Eastbound				N 115th St Westbound				0 Northbound				E Driveway Southbound				15-min Total	Rolling One Hour	
	UT	LT	TH	RT	UT	LT	TH	RT	UT	LT	TH	RT	UT	LT	TH	RT			
4:00 PM	0	5	59	0	0	0	74	11	0	0	0	0	0	37	0	19	205	0	
4:15 PM	0	6	60	0	0	0	73	19	0	0	0	0	0	31	0	15	204	0	
4:30 PM	0	6	83	0	0	0	77	14	0	0	0	0	0	40	0	21	241	0	
4:45 PM	0	5	80	0	0	0	54	9	0	0	0	0	0	27	0	15	190	840	
5:00 PM	0	3	69	0	0	0	69	21	0	0	0	0	0	39	0	12	213	848	
5:15 PM	0	6	51	0	0	0	56	15	0	0	0	0	0	30	0	9	167	811	
5:30 PM	0	3	86	0	0	0	63	10	0	0	0	0	0	18	0	14	194	764	
5:45 PM	0	7	57	0	0	0	65	8	0	0	0	0	0	22	0	7	166	740	
Count Total	0	41	545	0	0	0	531	107	0	0	0	0	0	244	0	112	1,580	0	
Peak Hour	All	0	20	292	0	0	0	273	63	0	0	0	0	0	137	0	63	848	0
	HV	0	0	2	0	0	0	3	7	0	0	0	0	0	6	0	3	21	0
	HV%	-	0%	1%	-	-	-	1%	11%	-	-	-	-	-	4%	-	5%	2%	0

Note: Two-hour count summary volumes include heavy vehicles but exclude bicycles in overall count.

Interval Start	Heavy Vehicle Totals					Bicycles					Pedestrians (Crossing Leg)				
	EB	WB	NB	SB	Total	EB	WB	NB	SB	Total	East	West	North	South	Total
4:00 PM	1	4	0	2	7	1	0	0	0	1	2	0	5	0	7
4:15 PM	0	5	0	0	5	0	0	0	1	1	0	0	1	0	1
4:30 PM	2	1	0	4	7	0	0	0	1	1	1	0	3	0	4
4:45 PM	0	1	0	3	4	0	0	0	0	0	1	1	5	0	7
5:00 PM	0	3	0	2	5	0	0	0	0	0	2	0	5	0	7
5:15 PM	0	5	0	1	6	0	0	0	1	1	1	0	5	0	6
5:30 PM	0	0	0	1	1	0	0	0	1	1	0	1	8	0	9
5:45 PM	0	5	0	2	7	0	0	0	0	0	2	0	5	0	7
Count Total	3	24	0	15	42	1	0	0	4	5	9	2	37	0	48
Peak Hr	2	10	0	9	21	0	0	0	2	2	4	1	14	0	19

Two-Hour Count Summaries - Heavy Vehicles														15-min Total	Rolling One Hour			
Interval Start	N 115th St				N 115th St				0				E Driveway					
	Eastbound				Westbound				Northbound				Southbound					
	UT	LT	TH	RT	UT	LT	TH	RT	UT	LT	TH	RT	UT	LT	TH	RT		
4:00 PM	0	1	0	0	0	0	2	2	0	0	0	0	0	1	0	1	7	0
4:15 PM	0	0	0	0	0	0	2	3	0	0	0	0	0	0	0	0	5	0
4:30 PM	0	0	2	0	0	0	0	1	0	0	0	0	0	2	0	2	7	0
4:45 PM	0	0	0	0	0	0	0	1	0	0	0	0	0	2	0	1	4	23
5:00 PM	0	0	0	0	0	0	1	2	0	0	0	0	0	2	0	0	5	21
5:15 PM	0	0	0	0	0	0	2	3	0	0	0	0	0	1	0	0	6	22
5:30 PM	0	0	0	0	0	0	0	0	0	0	0	0	0	1	0	0	1	16
5:45 PM	0	0	0	0	0	0	3	2	0	0	0	0	0	2	0	0	7	19
Count Total	0	1	2	0	0	0	10	14	0	0	0	0	0	11	0	4	42	0
Peak Hour	0	0	2	0	0	0	3	7	0	0	0	0	0	6	0	3	21	0

Two-Hour Count Summaries - Bikes														15-min Total	Rolling One Hour
Interval Start	N 115th St			N 115th St			0			E Driveway					
	Eastbound			Westbound			Northbound			Southbound					
	LT	TH	RT	LT	TH	RT	LT	TH	RT	LT	TH	RT			
4:00 PM	0	1	0	0	0	0	0	0	0	0	0	0	1	0	
4:15 PM	0	0	0	0	0	0	0	0	0	1	0	0	1	0	
4:30 PM	0	0	0	0	0	0	0	0	0	0	0	1	1	0	
4:45 PM	0	0	0	0	0	0	0	0	0	0	0	0	0	3	
5:00 PM	0	0	0	0	0	0	0	0	0	0	0	0	0	2	
5:15 PM	0	0	0	0	0	0	0	0	0	1	0	0	1	2	
5:30 PM	0	0	0	0	0	0	0	0	0	1	0	0	1	2	
5:45 PM	0	0	0	0	0	0	0	0	0	0	0	0	0	2	
Count Total	0	1	0	0	0	0	0	0	0	3	0	1	5	0	
Peak Hour	0	0	0	0	0	0	0	0	0	1	0	1	2	0	

Note: U-Turn volumes for bikes are included in Left-Turn, if any.

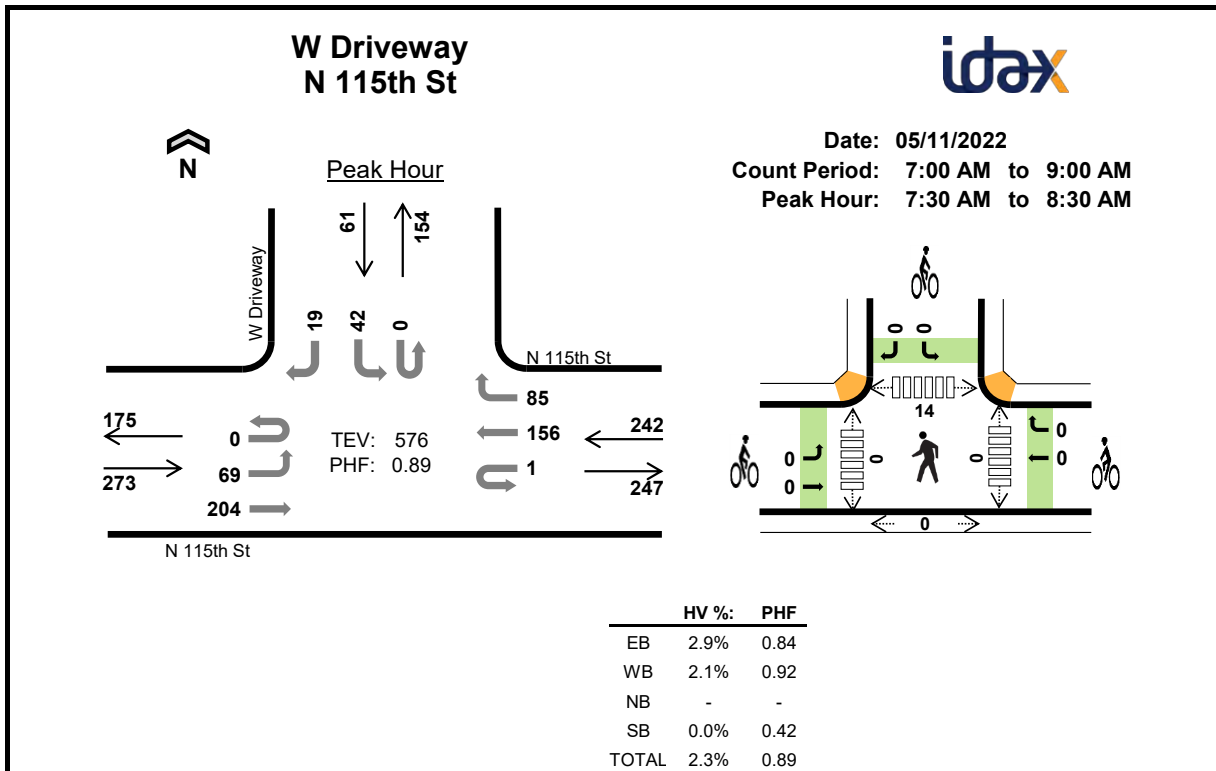

Two-Hour Count Summaries

Interval Start	N 115th St Eastbound				N 115th St Westbound				0 Northbound				W Driveway Southbound				15-min Total	Rolling One Hour	
	UT	LT	TH	RT	UT	LT	TH	RT	UT	LT	TH	RT	UT	LT	TH	RT			
	7:00 AM	0	17	34	0	0	0	20	21	0	0	0	0	0	0	0			1
7:15 AM	0	17	40	0	0	0	21	26	0	0	0	0	0	7	0	4	115	0	
7:30 AM	0	16	40	0	0	0	34	24	0	0	0	0	0	26	0	10	150	0	
7:45 AM	0	22	59	0	0	0	44	22	0	0	0	0	0	10	0	4	161	519	
8:00 AM	0	17	47	0	0	0	36	18	0	0	0	0	0	5	0	3	126	552	
8:15 AM	0	14	58	0	1	0	42	21	0	0	0	0	0	1	0	2	139	576	
8:30 AM	0	13	56	0	0	0	39	11	0	0	0	0	0	2	0	2	123	549	
8:45 AM	0	4	53	0	1	0	47	19	0	0	0	0	0	2	0	1	127	515	
Count Total	0	120	387	0	2	0	283	162	0	0	0	0	0	53	0	27	1,034	0	
Peak Hour	All	0	69	204	0	1	0	156	85	0	0	0	0	0	42	0	19	576	0
	HV	0	0	8	0	0	0	5	0	0	0	0	0	0	0	0	0	13	0
	HV%	-	0%	4%	-	0%	-	3%	0%	-	-	-	-	-	0%	-	0%	2%	0

Note: Two-hour count summary volumes include heavy vehicles but exclude bicycles in overall count.

Interval Start	Heavy Vehicle Totals					Bicycles					Pedestrians (Crossing Leg)				
	EB	WB	NB	SB	Total	EB	WB	NB	SB	Total	East	West	North	South	Total
7:00 AM	2	0	0	0	2	0	0	0	0	0	0	0	1	0	1
7:15 AM	1	0	0	0	1	0	0	0	0	0	0	0	3	0	3
7:30 AM	1	2	0	0	3	0	0	0	0	0	0	0	4	0	4
7:45 AM	2	1	0	0	3	0	0	0	0	0	0	0	5	0	5
8:00 AM	3	1	0	0	4	0	0	0	0	0	0	0	2	0	2
8:15 AM	2	1	0	0	3	0	0	0	0	0	0	0	3	0	3
8:30 AM	0	1	0	0	1	0	0	0	0	0	0	0	4	0	4
8:45 AM	1	1	0	0	2	0	0	0	0	0	0	0	2	0	2
Count Total	12	7	0	0	19	0	0	0	0	0	0	0	24	0	24
Peak Hr	8	5	0	0	13	0	0	0	0	0	0	0	14	0	14

Two-Hour Count Summaries - Heavy Vehicles																		
Interval Start	N 115th St				N 115th St				0				W Driveway				15-min Total	Rolling One Hour
	Eastbound				Westbound				Northbound				Southbound					
	UT	LT	TH	RT	UT	LT	TH	RT	UT	LT	TH	RT	UT	LT	TH	RT		
7:00 AM	0	0	2	0	0	0	0	0	0	0	0	0	0	0	0	0	2	0
7:15 AM	0	1	0	0	0	0	0	0	0	0	0	0	0	0	0	0	1	0
7:30 AM	0	0	1	0	0	0	2	0	0	0	0	0	0	0	0	0	3	0
7:45 AM	0	0	2	0	0	0	1	0	0	0	0	0	0	0	0	0	3	9
8:00 AM	0	0	3	0	0	0	1	0	0	0	0	0	0	0	0	0	4	11
8:15 AM	0	0	2	0	0	0	1	0	0	0	0	0	0	0	0	0	3	13
8:30 AM	0	0	0	0	0	0	1	0	0	0	0	0	0	0	0	0	1	11
8:45 AM	0	0	1	0	0	0	1	0	0	0	0	0	0	0	0	0	2	10
Count Total	0	1	11	0	0	0	7	0	0	0	0	0	0	0	0	0	19	0
Peak Hour	0	0	8	0	0	0	5	0	0	0	0	0	0	0	0	0	13	0

Two-Hour Count Summaries - Bikes																	
Interval Start	N 115th St			N 115th St			0			W Driveway			15-min Total	Rolling One Hour			
	Eastbound			Westbound			Northbound			Southbound							
	LT	TH	RT	LT	TH	RT	LT	TH	RT	LT	TH	RT					
7:00 AM	0	0	0	0	0	0	0	0	0	0	0	0	0	0	0	0	0
7:15 AM	0	0	0	0	0	0	0	0	0	0	0	0	0	0	0	0	0
7:30 AM	0	0	0	0	0	0	0	0	0	0	0	0	0	0	0	0	0
7:45 AM	0	0	0	0	0	0	0	0	0	0	0	0	0	0	0	0	0
8:00 AM	0	0	0	0	0	0	0	0	0	0	0	0	0	0	0	0	0
8:15 AM	0	0	0	0	0	0	0	0	0	0	0	0	0	0	0	0	0
8:30 AM	0	0	0	0	0	0	0	0	0	0	0	0	0	0	0	0	0
8:45 AM	0	0	0	0	0	0	0	0	0	0	0	0	0	0	0	0	0
Count Total	0	0	0	0	0	0	0	0	0	0	0	0	0	0	0	0	0
Peak Hour	0	0	0	0	0	0	0	0	0	0	0	0	0	0	0	0	0

Note: U-Turn volumes for bikes are included in Left-Turn, if any.

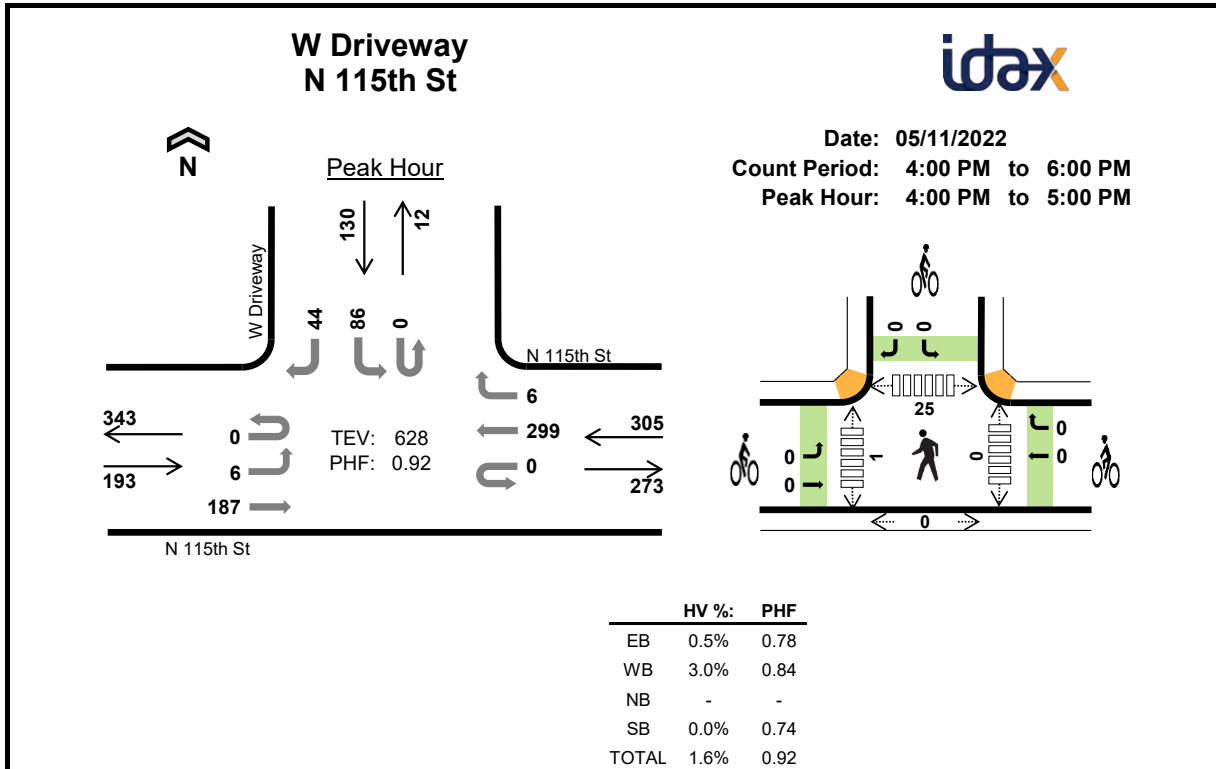

Two-Hour Count Summaries

Interval Start	N 115th St Eastbound				N 115th St Westbound				0 Northbound				W Driveway Southbound				15-min Total	Rolling One Hour	
	UT	LT	TH	RT	UT	LT	TH	RT	UT	LT	TH	RT	UT	LT	TH	RT			
4:00 PM	0	1	47	0	0	0	86	1	0	0	0	0	0	22	0	13	170	0	
4:15 PM	0	1	43	0	0	0	88	3	0	0	0	0	0	12	0	10	157	0	
4:30 PM	0	3	36	0	0	0	67	2	0	0	0	0	0	32	0	12	152	0	
4:45 PM	0	1	61	0	0	0	58	0	0	0	0	0	0	20	0	9	149	628	
5:00 PM	0	1	42	0	0	0	66	1	0	0	0	0	0	32	0	25	167	625	
5:15 PM	0	1	59	0	0	0	48	3	0	0	0	0	0	28	0	15	154	622	
5:30 PM	0	0	42	0	0	0	49	3	0	0	0	0	0	35	0	16	145	615	
5:45 PM	0	1	40	0	0	0	59	3	0	0	0	0	0	14	0	6	123	589	
Count Total	0	9	370	0	0	0	521	16	0	0	0	0	0	195	0	106	1,217	0	
Peak Hour	All	0	6	187	0	0	0	299	6	0	0	0	0	0	86	0	44	628	0
	HV	0	0	1	0	0	0	9	0	0	0	0	0	0	0	0	0	10	0
	HV%	-	0%	1%	-	-	-	3%	0%	-	-	-	-	-	0%	-	0%	2%	0

Note: Two-hour count summary volumes include heavy vehicles but exclude bicycles in overall count.

Interval Start	Heavy Vehicle Totals					Bicycles					Pedestrians (Crossing Leg)				
	EB	WB	NB	SB	Total	EB	WB	NB	SB	Total	East	West	North	South	Total
4:00 PM	0	3	0	0	3	0	0	0	0	0	0	1	6	0	7
4:15 PM	1	4	0	0	5	0	0	0	0	0	0	0	9	0	9
4:30 PM	0	1	0	0	1	0	0	0	0	0	0	0	3	0	3
4:45 PM	0	1	0	0	1	0	0	0	0	0	0	0	7	0	7
5:00 PM	0	2	0	0	2	0	1	0	0	1	0	0	4	0	4
5:15 PM	1	0	0	0	1	0	0	0	0	0	0	0	3	0	3
5:30 PM	0	0	0	0	0	0	0	0	0	0	0	0	7	0	7
5:45 PM	0	0	0	0	0	0	0	0	0	0	0	0	4	0	4
Count Total	2	11	0	0	13	0	1	0	0	1	0	1	43	0	44
Peak Hr	1	9	0	0	10	0	0	0	0	0	0	1	25	0	26

Two-Hour Count Summaries - Heavy Vehicles																		
Interval Start	N 115th St				N 115th St				0				W Driveway				15-min Total	Rolling One Hour
	Eastbound				Westbound				Northbound				Southbound					
	UT	LT	TH	RT	UT	LT	TH	RT	UT	LT	TH	RT	UT	LT	TH	RT		
4:00 PM	0	0	0	0	0	0	3	0	0	0	0	0	0	0	0	0	3	0
4:15 PM	0	0	1	0	0	0	4	0	0	0	0	0	0	0	0	0	5	0
4:30 PM	0	0	0	0	0	0	1	0	0	0	0	0	0	0	0	0	1	0
4:45 PM	0	0	0	0	0	0	1	0	0	0	0	0	0	0	0	0	1	10
5:00 PM	0	0	0	0	0	0	2	0	0	0	0	0	0	0	0	0	2	9
5:15 PM	0	0	1	0	0	0	0	0	0	0	0	0	0	0	0	0	1	5
5:30 PM	0	0	0	0	0	0	0	0	0	0	0	0	0	0	0	0	0	4
5:45 PM	0	0	0	0	0	0	0	0	0	0	0	0	0	0	0	0	0	3
Count Total	0	0	2	0	0	0	11	0	0	0	0	0	0	0	0	0	13	0
Peak Hour	0	0	1	0	0	0	9	0	0	0	0	0	0	0	0	0	10	0

Two-Hour Count Summaries - Bikes														
Interval Start	N 115th St			N 115th St			0			W Driveway			15-min Total	Rolling One Hour
	Eastbound			Westbound			Northbound			Southbound				
	LT	TH	RT	LT	TH	RT	LT	TH	RT	LT	TH	RT		
4:00 PM	0	0	0	0	0	0	0	0	0	0	0	0	0	0
4:15 PM	0	0	0	0	0	0	0	0	0	0	0	0	0	0
4:30 PM	0	0	0	0	0	0	0	0	0	0	0	0	0	0
4:45 PM	0	0	0	0	0	0	0	0	0	0	0	0	0	0
5:00 PM	0	0	0	0	1	0	0	0	0	0	0	0	1	1
5:15 PM	0	0	0	0	0	0	0	0	0	0	0	0	0	1
5:30 PM	0	0	0	0	0	0	0	0	0	0	0	0	0	1
5:45 PM	0	0	0	0	0	0	0	0	0	0	0	0	0	1
Count Total	0	0	0	0	1	0	0	0	0	0	0	0	1	0
Peak Hour	0	0	0	0	0	0	0	0	0	0	0	0	0	0

Note: U-Turn volumes for bikes are included in Left-Turn, if any.

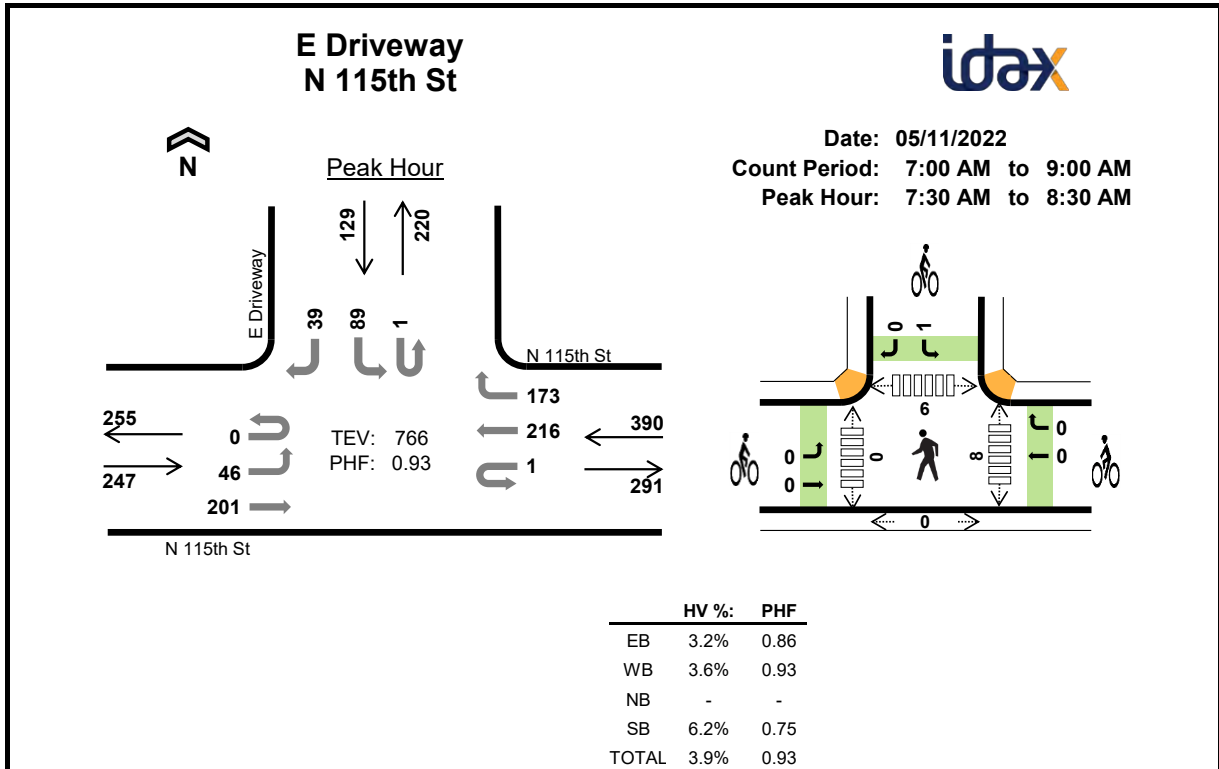

Two-Hour Count Summaries

Interval Start	N 115th St Eastbound				N 115th St Westbound				0 Northbound				E Driveway Southbound				15-min Total	Rolling One Hour	
	UT	LT	TH	RT	UT	LT	TH	RT	UT	LT	TH	RT	UT	LT	TH	RT			
7:00 AM	0	9	25	0	0	0	39	30	0	0	0	0	0	11	0	7	121	0	
7:15 AM	0	15	35	0	0	0	52	43	0	0	0	0	0	9	0	4	158	0	
7:30 AM	0	5	60	0	0	0	54	43	0	0	0	0	0	33	0	10	205	0	
7:45 AM	0	12	60	0	1	0	59	38	0	0	0	0	0	21	0	7	198	682	
8:00 AM	0	10	43	0	0	0	53	37	0	0	0	0	1	18	0	7	169	730	
8:15 AM	0	19	38	0	0	0	50	55	0	0	0	0	0	17	0	15	194	766	
8:30 AM	0	14	43	0	0	0	45	35	0	0	0	0	0	24	0	8	169	730	
8:45 AM	0	14	43	0	0	0	56	50	0	0	0	0	0	24	0	15	202	734	
Count Total	0	98	347	0	1	0	408	331	0	0	0	0	1	157	0	73	1,416	0	
Peak Hour	All	0	46	201	0	1	0	216	173	0	0	0	0	1	89	0	39	766	0
	HV	0	1	7	0	0	0	5	9	0	0	0	0	0	7	0	1	30	0
	HV%	-	2%	3%	-	0%	-	2%	5%	-	-	-	-	0%	8%	-	3%	4%	0

Note: Two-hour count summary volumes include heavy vehicles but exclude bicycles in overall count.

Interval Start	Heavy Vehicle Totals					Bicycles					Pedestrians (Crossing Leg)				
	EB	WB	NB	SB	Total	EB	WB	NB	SB	Total	East	West	North	South	Total
7:00 AM	2	1	0	1	4	1	0	0	0	1	0	0	2	0	2
7:15 AM	0	7	0	2	9	0	0	0	0	0	1	0	2	0	3
7:30 AM	1	8	0	1	10	0	0	0	1	1	2	0	2	0	4
7:45 AM	2	1	0	4	7	0	0	0	0	0	1	0	0	0	1
8:00 AM	3	3	0	2	8	0	0	0	0	0	1	0	2	0	3
8:15 AM	2	2	0	1	5	0	0	0	0	0	4	0	2	0	6
8:30 AM	0	3	0	2	5	0	0	0	0	0	2	0	2	0	4
8:45 AM	1	3	0	3	7	0	0	0	0	0	2	0	2	0	4
Count Total	11	28	0	16	55	1	0	0	1	2	13	0	14	0	27
Peak Hr	8	14	0	8	30	0	0	0	1	1	8	0	6	0	14

Two-Hour Count Summaries - Heavy Vehicles																		
Interval Start	N 115th St				N 115th St				0				E Driveway				15-min Total	Rolling One Hour
	Eastbound				Westbound				Northbound				Southbound					
	UT	LT	TH	RT	UT	LT	TH	RT	UT	LT	TH	RT	UT	LT	TH	RT		
7:00 AM	0	1	1	0	0	0	0	1	0	0	0	0	0	1	0	0	4	0
7:15 AM	0	0	0	0	0	0	4	3	0	0	0	0	0	2	0	0	9	0
7:30 AM	0	1	0	0	0	0	3	5	0	0	0	0	0	1	0	0	10	0
7:45 AM	0	0	2	0	0	0	0	1	0	0	0	0	0	3	0	1	7	30
8:00 AM	0	0	3	0	0	0	1	2	0	0	0	0	0	2	0	0	8	34
8:15 AM	0	0	2	0	0	0	1	1	0	0	0	0	0	1	0	0	5	30
8:30 AM	0	0	0	0	0	0	1	2	0	0	0	0	0	2	0	0	5	25
8:45 AM	0	1	0	0	0	0	1	2	0	0	0	0	0	3	0	0	7	25
Count Total	0	3	8	0	0	0	11	17	0	0	0	0	0	15	0	1	55	0
Peak Hour	0	1	7	0	0	0	5	9	0	0	0	0	0	7	0	1	30	0

Two-Hour Count Summaries - Bikes														
Interval Start	N 115th St			N 115th St			0			E Driveway			15-min Total	Rolling One Hour
	Eastbound			Westbound			Northbound			Southbound				
	LT	TH	RT	LT	TH	RT	LT	TH	RT	LT	TH	RT		
7:00 AM	0	1	0	0	0	0	0	0	0	0	0	0	1	0
7:15 AM	0	0	0	0	0	0	0	0	0	0	0	0	0	0
7:30 AM	0	0	0	0	0	0	0	0	0	0	0	1	0	0
7:45 AM	0	0	0	0	0	0	0	0	0	0	0	0	0	2
8:00 AM	0	0	0	0	0	0	0	0	0	0	0	0	0	1
8:15 AM	0	0	0	0	0	0	0	0	0	0	0	0	0	1
8:30 AM	0	0	0	0	0	0	0	0	0	0	0	0	0	0
8:45 AM	0	0	0	0	0	0	0	0	0	0	0	0	0	0
Count Total	0	1	0	0	0	0	0	0	0	0	0	1	0	2
Peak Hour	0	0	0	0	0	0	0	0	0	0	0	1	0	0

Note: U-Turn volumes for bikes are included in Left-Turn, if any.

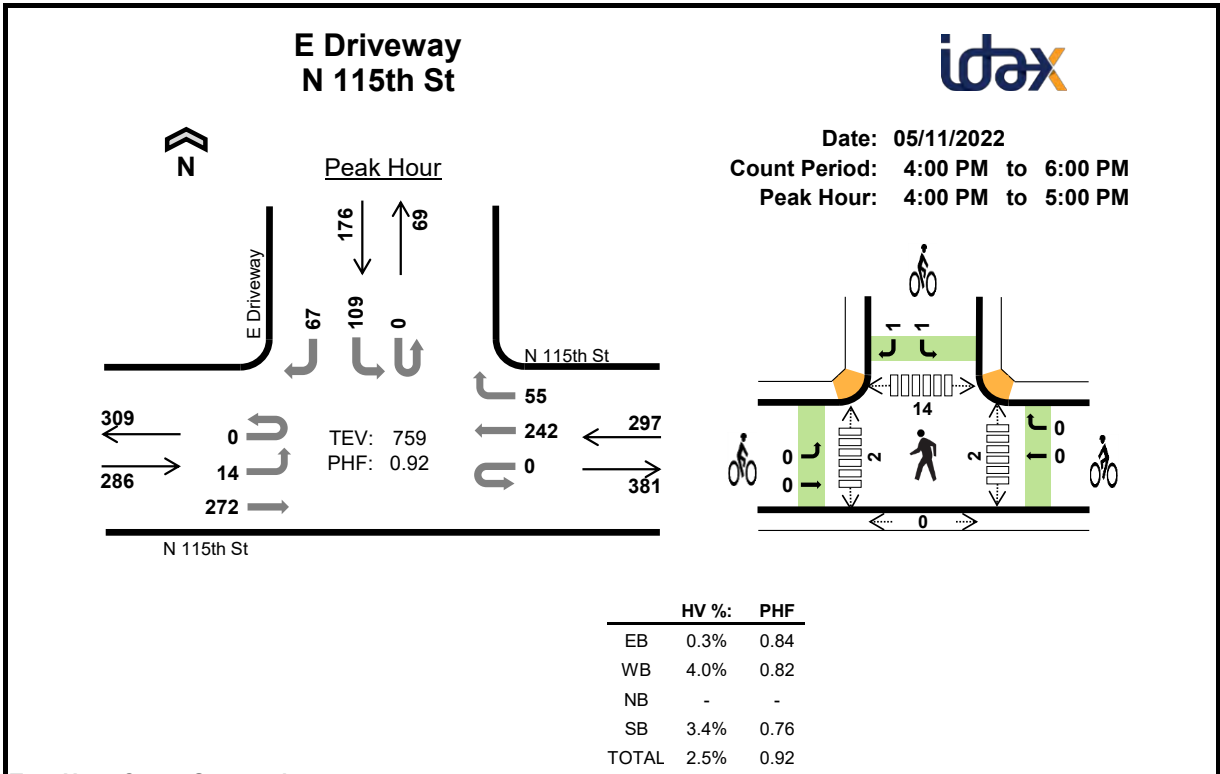

Two-Hour Count Summaries

Interval Start	N 115th St Eastbound				N 115th St Westbound				0 Northbound				E Driveway Southbound				15-min Total	Rolling One Hour	
	UT	LT	TH	RT	UT	LT	TH	RT	UT	LT	TH	RT	UT	LT	TH	RT			
4:00 PM	0	4	68	0	0	0	71	20	0	0	0	0	0	26	0	18	207	0	
4:15 PM	0	3	53	0	0	0	71	18	0	0	0	0	0	37	0	21	203	0	
4:30 PM	0	4	69	0	0	0	52	2	0	0	0	0	0	28	0	14	169	0	
4:45 PM	0	3	82	0	0	0	48	15	0	0	0	0	0	18	0	14	180	759	
5:00 PM	0	5	71	0	0	0	55	12	0	0	0	0	0	35	0	8	186	738	
5:15 PM	0	12	73	0	0	0	43	11	0	0	0	0	0	18	0	10	167	702	
5:30 PM	0	4	80	0	0	0	42	8	0	0	0	0	0	28	0	10	172	705	
5:45 PM	0	3	50	0	0	0	55	14	0	0	0	0	0	19	0	9	150	675	
Count Total	0	38	546	0	0	0	437	100	0	0	0	0	0	209	0	104	1,434	0	
Peak Hour	All	0	14	272	0	0	0	242	55	0	0	0	0	0	109	0	67	759	0
	HV	0	0	1	0	0	0	7	5	0	0	0	0	0	4	0	2	19	0
	HV%	-	0%	0%	-	-	-	3%	9%	-	-	-	-	-	4%	-	3%	3%	0

Note: Two-hour count summary volumes include heavy vehicles but exclude bicycles in overall count.

Interval Start	Heavy Vehicle Totals					Bicycles					Pedestrians (Crossing Leg)				
	EB	WB	NB	SB	Total	EB	WB	NB	SB	Total	East	West	North	South	Total
4:00 PM	0	4	0	2	6	0	0	0	1	1	0	0	3	0	3
4:15 PM	1	5	0	2	8	0	0	0	0	0	1	0	5	0	6
4:30 PM	0	1	0	1	2	0	0	0	0	0	0	1	2	0	3
4:45 PM	0	2	0	1	3	0	0	0	1	1	1	1	4	0	6
5:00 PM	0	3	0	2	5	0	0	0	0	0	0	1	2	0	3
5:15 PM	1	1	0	1	3	0	0	0	1	1	0	0	4	0	4
5:30 PM	0	0	0	0	0	0	0	0	0	0	0	2	5	0	7
5:45 PM	0	2	0	2	4	0	0	0	0	0	0	0	1	0	1
Count Total	2	18	0	11	31	0	0	0	3	3	2	5	26	0	33
Peak Hr	1	12	0	6	19	0	0	0	2	2	2	2	14	0	18

Two-Hour Count Summaries - Heavy Vehicles																		
Interval Start	N 115th St				N 115th St				0				E Driveway				15-min Total	Rolling One Hour
	Eastbound				Westbound				Northbound				Southbound					
	UT	LT	TH	RT	UT	LT	TH	RT	UT	LT	TH	RT	UT	LT	TH	RT		
4:00 PM	0	0	0	0	0	0	2	2	0	0	0	0	0	1	0	1	6	0
4:15 PM	0	0	1	0	0	0	3	2	0	0	0	0	0	1	0	1	8	0
4:30 PM	0	0	0	0	0	0	1	0	0	0	0	0	0	1	0	0	2	0
4:45 PM	0	0	0	0	0	0	1	1	0	0	0	0	0	1	0	0	3	19
5:00 PM	0	0	0	0	0	0	1	2	0	0	0	0	0	2	0	0	5	18
5:15 PM	0	0	1	0	0	0	0	1	0	0	0	0	0	1	0	0	3	13
5:30 PM	0	0	0	0	0	0	0	0	0	0	0	0	0	0	0	0	0	11
5:45 PM	0	0	0	0	0	0	0	2	0	0	0	0	0	2	0	0	4	12
Count Total	0	0	2	0	0	0	8	10	0	0	0	0	0	9	0	2	31	0
Peak Hour	0	0	1	0	0	0	7	5	0	0	0	0	0	4	0	2	19	0

Two-Hour Count Summaries - Bikes														
Interval Start	N 115th St			N 115th St			0			E Driveway			15-min Total	Rolling One Hour
	Eastbound			Westbound			Northbound			Southbound				
	LT	TH	RT	LT	TH	RT	LT	TH	RT	LT	TH	RT		
4:00 PM	0	0	0	0	0	0	0	0	0	0	0	1	1	0
4:15 PM	0	0	0	0	0	0	0	0	0	0	0	0	0	0
4:30 PM	0	0	0	0	0	0	0	0	0	0	0	0	0	0
4:45 PM	0	0	0	0	0	0	0	0	0	1	0	0	1	2
5:00 PM	0	0	0	0	0	0	0	0	0	0	0	0	0	1
5:15 PM	0	0	0	0	0	0	0	0	0	0	0	1	1	2
5:30 PM	0	0	0	0	0	0	0	0	0	0	0	0	0	2
5:45 PM	0	0	0	0	0	0	0	0	0	0	0	0	0	1
Count Total	0	0	0	0	0	0	0	0	0	1	0	2	3	0
Peak Hour	0	0	0	0	0	0	0	0	0	1	0	1	2	0

Note: U-Turn volumes for bikes are included in Left-Turn, if any.

Appendix C Pipeline Projects

Appendix C - Pipeline Projects

#	Project Address	Number	Description	Do we have the study?
1.	1130 N Norhtgate Way	3030820-LU	5-story, 69 sleeping rooms, 1 parking space.	Parking only
2.	12220 Aurora AVE N	3039892-EG	6 new mixed-use apartment buildings, 1,400,000 gross area, 2,000 dwelling units, 650 parking	-
3.	12301 Stone Ave N	3029876-LU	19 3-story townhouse buildings (113 Units total) and 3 live-work units. 156 parking	Yes
4.	12201 Stone Ave N/11762 Aurora AVE N	3036032-LU/3036031-EG	24 3-story townhouse buildings and two 5-story apartment buildings. (242 units total) 316 parking.	Yes
5.	10533 Stone Ave N	3039300-LU	4 story residential townhouse structure. (24total)	
6.	11224 Meridian AVE N	3032771-LU	4-story, 57 unit apartment building with 41 parking spaces.	Yes
7.	2101 N 113th ST	3039761-LU	20+ townhouse on vancant portion of Lot.	
8.	1724 N 107th ST	3034886-LU	5 story apartment building with 13 small efficiency dwelling unit, 4 efficiency dwelling units, and 13 apartments (30 units total). No parking	
9.	Northgate Mall MPD.	3031306-LU	Northgate Mall MPD. Includes all development proposed not completed and operating as of Jan 2023.	Yes
10.	151 NE 103rd St	3036540-LU	7 Story, 232 unit apartment, no parking	Yes
11.	12800 Aurora Ave N	3020863-LU	Seattle North Police Precinct. TIA by Heffron.	Yes
12.	12245 Aurora Ave N	3039521-EG	124 apartments, 90 supportive housing units, child care, 45 parking stalls. No TIA.	
13.	1911 N 120th St	3039953-LU	6 townhouses, 1 single-family house, 7 parking stalls. No TIA.	
14.	11302 Meridian Ave N	3038025-LU	Fire Station #31. No TIA.	
15.	1001 N 109th St	3040343-EG	90 apartments, 0 stalls. No TIA.	
16.	10631 8th Ave NE	3035925-LU	409 apartments, 256 stalls. TIA by TENW.	Yes
17.	10712 5th Ave NE	3030779-LU	235 apartments, 4,188 sf commercial, 203 stalls. TIA by Gibson.	Yes
18.	1020 NE Northgate Way	3039050-LU	179 apartments, 8,186 sf retail, 88 stalls. No TIA.	
19.	545 NE 112th Street	3029327-LU	82 apartments, 0 stalls. No TIA.	
20.	11057 8th Ave NE	3034765-LU	89 apartments, 8,400 sf child care, 28 stalls. TIA by Heffron.	Yes
21.	11201 Roosevelt Way NE	3034991-LU	291 apartments, 4 live-work units, 3,225 sf commercial, 207 stalls. TIA by TENW.	Yes

Appendix D LOS Definitions

Highway Capacity Manual 2010/6th Edition

Signalized intersection level of service (LOS) is defined in terms of a weighted average control delay for the entire intersection. Control delay quantifies the increase in travel time that a vehicle experiences due to the traffic signal control as well as provides a surrogate measure for driver discomfort and fuel consumption. Signalized intersection LOS is stated in terms of average control delay per vehicle (in seconds) during a specified time period (e.g., weekday PM peak hour). Control delay is a complex measure based on many variables, including signal phasing and coordination (i.e., progression of movements through the intersection and along the corridor), signal cycle length, and traffic volumes with respect to intersection capacity and resulting queues. Table 1 summarizes the LOS criteria for signalized intersections, as described in the *Highway Capacity Manual 2010* and 6th Edition (Transportation Research Board, 2010 and 2016, respectively).

Table 1. Level of Service Criteria for Signalized Intersections

Level of Service	Average Control Delay (seconds/vehicle)	General Description
A	≤10	Free Flow
B	>10 – 20	Stable Flow (slight delays)
C	>20 – 35	Stable flow (acceptable delays)
D	>35 – 55	Approaching unstable flow (tolerable delay, occasionally wait through more than one signal cycle before proceeding)
E	>55 – 80	Unstable flow (intolerable delay)
F ¹	>80	Forced flow (congested and queues fail to clear)

Source: *Highway Capacity Manual 2010 and 6th Edition*, Transportation Research Board, 2010 and 2016, respectively.

1. If the volume-to-capacity (v/c) ratio for a lane group exceeds 1.0 LOS F is assigned to the individual lane group. LOS for overall approach or intersection is determined solely by the control delay.

Unsignalized intersection LOS criteria can be further reduced into two intersection types: all-way stop and two-way stop control. All-way stop control intersection LOS is expressed in terms of the weighted average control delay of the overall intersection or by approach. Two-way stop-controlled intersection LOS is defined in terms of the average control delay for each minor-street movement (or shared movement) as well as major-street left-turns. This approach is because major-street through vehicles are assumed to experience zero delay, a weighted average of all movements results in very low overall average delay, and this calculated low delay could mask deficiencies of minor movements. Table 2 shows LOS criteria for unsignalized intersections.

Table 2. Level of Service Criteria for Unsignalized Intersections

Level of Service	Average Control Delay (seconds/vehicle)
A	0 – 10
B	>10 – 15
C	>15 – 25
D	>25 – 35
E	>35 – 50
F ¹	>50

Source: *Highway Capacity Manual 2010 and 6th Edition*, Transportation Research Board, 2010 and 2016, respectively.

1. If the volume-to-capacity (v/c) ratio exceeds 1.0, LOS F is assigned an individual lane group for all unsignalized intersections, or minor street approach at two-way stop-controlled intersections. Overall intersection LOS is determined solely by control delay.

Appendix E LOS Worksheets

Appendix E Available Upon Request

Appendix F Transit Analysis

Transit Analysis - 75% SOV

Net New NA Transit TG				Assume:	Net New MIMP Transit TG				
		AM	PM				AM	PM	
Total		13	8	100%	2023	Total	58	49	100%
				2%	2040				

	Existing				No Action										Action Alternative							
	Onboard Capacity Analysis				Total TG (Peak Hour)	Dist	Onboard Capacity Analysis						Total TG (Peak Hour)	Dist	Onboard Capacity Analysis							
	Route/Stop	Service	Direction	Total Capacity			Bus Passenger Load	Utilization	Total Capacity	Background Growth (1% annual)	Bus Passenger Load with Background Only	Additional NA (4-hr period)			TOTAL Future No Action Bus Passenger Load	Utilization	Total Capacity	TOTAL Future No Action Bus Passenger Load	Additional MIMP (4-hr period)	Total Future Action Bus Passenger Load	Utilization	
AM	345_S_AM	345	Shoreline/	S	296	45	15%	4	30%	296	18	63	16	79	27%	17	30%	296	79	68	147	50%
	345_N_AM	345	Northgate	N	296	54	18%	3	30%	296	21	75	12	87	29%	17	30%	296	75	68	143	48%
	346_S_AM	346	Shoreline/	S	370	77	21%	1	5%	370	31	108	4	112	30%	4	5%	370	108	16	124	33%
	346_N_AM	346	Northgate	N	333	77	23%	1	5%	333	31	108	4	112	34%	4	5%	333	108	16	124	37%
	40_S_AM	40	Downtown/	S	1,520	116	8%	1	8%	1,520	46	162	4	166	11%	4	8%	1,520	162	16	178	12%
	40_N_AM	40	Ballard/DT	N	988	126	13%	1	8%	988	50	177	4	181	18%	4	8%	988	177	16	193	19%
	675_N_AM	675	Shoreline/D	N	1,404	355	25%	1	8%	1,404	142	497	4	501	36%	4	8%	1,404	497	16	513	37%
	675_S_AM	675	T	S	2,496	550	22%	1	8%	2,496	220	771	4	775	31%	4	8%	2,496	771	16	787	32%
								13									58					

	Existing				No Action										Action Alternative							
	Onboard Capacity Analysis				Total TG (Peak Hour)	Dist	Onboard Capacity Analysis						Total TG (Peak Hour)	Dist	Onboard Capacity Analysis							
	Route/Stop	Service	Direction	Total Capacity			Bus Passenger Load	Utilization	Total Capacity	Background Growth (1% annual)	Bus Passenger Load with Background Only	Additional NA (4-hr period)			TOTAL Future No Action Bus Passenger Load	Utilization	Total Capacity	TOTAL Future No Action Bus Passenger Load	Additional MIMP (4-hr period)	Total Future Action Bus Passenger Load	Utilization	
PM	345_S_PM	345	Shoreline/	S	444	84	19%	2	30%	444	34	118	8	126	28%	15	30%	444	126	60	186	42%
	345_N_PM	345	Northgate	N	407	101	25%	2	30%	407	41	142	8	150	37%	14	30%	407	142	56	198	49%
	346_S_PM	346	Shoreline/	S	407	102	25%	0	5%	407	41	143	0	143	35%	2	5%	407	143	8	151	37%
	346_N_PM	346	Northgate	N	370	114	31%	0	5%	370	46	160	0	160	43%	2	5%	370	160	8	168	45%
	40_S_PM	40	Downtown/	S	1,672	255	15%	1	8%	1,672	102	357	4	361	22%	4	8%	1,672	357	16	373	22%
	40_N_PM	40	Ballard/DT	N	1,672	202	12%	1	8%	1,672	81	283	4	287	17%	4	8%	1,672	283	16	299	18%
	675_N_PM	675	Shoreline/D	N	2,808	727	26%	1	8%	2,808	291	1018	4	1,022	36%	4	8%	2,808	1,018	16	1,034	37%
	675_S_PM	675	T	S	2,028	546	27%	1	8%	2,028	219	765	4	769	38%	4	8%	2,028	765	16	781	38%
								8									49					

Transit Analysis - 65% SOV

Net New NA Transit TG				Assume:	Net New MIMP Transit TG				
		AM	PM				AM	PM	
Total		19	12	100%	2023	Total	82	70	100%
				2%	2040				

AM	Existing				No Action										Action Alternative								
	Onboard Capacity Analysis				Total TG (Peak Hour)	Dist	Onboard Capacity Analysis						Total TG (Peak Hour)	Dist	Onboard Capacity Analysis								
	Route/Stop	Service	Direction	Total Capacity			Bus Passenger Load	Utilization	Total Capacity	Background Growth (1% annual)	Bus Passenger Load with Background Only	Additional NA (4-hr period)			TOTAL Future No Action Bus Passenger Load	Utilization	Total Capacity	TOTAL Future No Action Bus Passenger Load	Additional MIMP (4-hr period)	Total Future Action Bus Passenger Load	Utilization		
345_S_AM	345	Shoreline/	S	296	45	15%	6	30%	296	18	63	24	87	29%	25	30%	296	87	100	187	63%		
345_N_AM		Northgate	N	296	54	18%	6	30%	296	21	75	24	99	33%	25	30%	296	75	100	175	59%		
346_S_AM	346	Shoreline/	S	370	77	21%	2	5%	370	31	108	8	116	31%	4	5%	370	108	16	124	33%		
346_N_AM		Northgate	N	333	77	23%	1	5%	333	31	108	4	112	34%	4	5%	333	108	16	124	37%		
40_S_AM	40	Downtown/	S	1,520	116	8%	1	8%	1,520	46	162	4	166	11%	6	8%	1,520	162	24	186	12%		
40_N_AM		Ballard/DT	N	988	126	13%	1	8%	988	50	177	4	181	18%	6	8%	988	177	24	201	20%		
675_N_AM	675	Shoreline/D	N	1,404	355	25%	1	8%	1,404	142	497	4	501	36%	6	8%	1,404	497	24	521	37%		
675_S_AM		T	S	2,496	550	22%	1	8%	2,496	220	771	4	775	31%	6	8%	2,496	771	24	795	32%		
							19											82					

PM	Existing				No Action										Action Alternative								
	Onboard Capacity Analysis				Total TG (Peak Hour)	Dist	Onboard Capacity Analysis						Total TG (Peak Hour)	Dist	Onboard Capacity Analysis								
	Route/Stop	Service	Direction	Total Capacity			Bus Passenger Load	Utilization	Total Capacity	Background Growth (1% annual)	Bus Passenger Load with Background Only	Additional NA (4-hr period)			TOTAL Future No Action Bus Passenger Load	Utilization	Total Capacity	TOTAL Future No Action Bus Passenger Load	Additional MIMP (4-hr period)	Total Future Action Bus Passenger Load	Utilization		
345_S_PM	345	Shoreline/	S	444	84	19%	3	30%	444	34	118	12	130	29%	21	30%	444	130	84	214	48%		
345_N_PM		Northgate	N	407	101	25%	3	30%	407	41	142	12	154	38%	21	30%	407	142	84	226	55%		
346_S_PM	346	Shoreline/	S	407	102	25%	1	5%	407	41	143	4	147	36%	4	5%	407	143	16	159	39%		
346_N_PM		Northgate	N	370	114	31%	1	5%	370	46	160	4	164	44%	4	5%	370	160	16	176	47%		
40_S_PM	40	Downtown/	S	1,672	255	15%	1	8%	1,672	102	357	4	361	22%	5	8%	1,672	357	20	377	23%		
40_N_PM		Ballard/DT	N	1,672	202	12%	1	8%	1,672	81	283	4	287	17%	5	8%	1,672	283	20	303	18%		
675_N_PM	675	Shoreline/D	N	2,808	727	26%	1	8%	2,808	291	1018	4	1,022	36%	5	8%	2,808	1,018	20	1,038	37%		
675_S_PM		T	S	2,028	546	27%	1	8%	2,028	219	765	4	769	38%	5	8%	2,028	765	20	785	39%		
							12											48					

Transit Analysis - 50% SOV

Net New NA Transit TG				Assume:	Net New MIMP Transit TG			
	AM	PM		2023	AM	PM		
Total	28	18	100%	2040	124	105	100%	
				2%				

	Existing				No Action										Action Alternative							
	Onboard Capacity Analysis				Total TG (Peak Hour)	Dist	Onboard Capacity Analysis						Total TG (Peak Hour)	Dist	Onboard Capacity Analysis							
	Route/Stop	Service	Direction	Total Capacity			Bus Passenger Load	Utilization	Total Capacity	Background Growth (1% annual)	Bus Passenger Load with Background Only	Additional NA (4-hr period)			TOTAL Future No Action Bus Passenger Load	Utilization	Total Capacity	TOTAL Future No Action Bus Passenger Load	Additional MIMP (4-hr period)	Total Future Action Bus Passenger Load	Utilization	
AM	345_S_AM	345	Shoreline/	S	296	45	15%	8	30%	296	18	63	32	95	32%	38	30%	296	95	152	247	83%
	345_N_AM	345	Northgate	N	296	54	18%	8	30%	296	21	75	32	107	36%	38	30%	296	75	152	227	77%
	346_S_AM	346	Shoreline/	S	370	77	21%	2	5%	370	31	108	8	116	31%	6	5%	370	108	24	132	36%
	346_N_AM		Northgate	N	333	77	23%	1	5%	333	31	108	4	112	34%	6	5%	333	108	24	132	40%
	40_S_AM	40	Downtown/	S	1,520	116	8%	2	8%	1,520	46	162	8	170	11%	9	8%	1,520	162	36	198	13%
	40_N_AM		Ballard/DT	N	988	126	13%	2	8%	988	50	177	8	185	19%	9	8%	988	177	36	213	22%
	675_N_AM	675	Shoreline/D	N	1,404	355	25%	2	8%	1,404	142	497	8	505	36%	9	8%	1,404	497	36	533	38%
	675_S_AM		T	S	2,496	550	22%	2	8%	2,496	220	771	8	779	31%	9	8%	2,496	771	36	807	32%
								27									124					

	Existing				No Action										Action Alternative							
	Onboard Capacity Analysis				Total TG (Peak Hour)	Dist	Onboard Capacity Analysis						Total TG (Peak Hour)	Dist	Onboard Capacity Analysis							
	Route/Stop	Service	Direction	Total Capacity			Bus Passenger Load	Utilization	Total Capacity	Background Growth (1% annual)	Bus Passenger Load with Background Only	Additional NA (4-hr period)			TOTAL Future No Action Bus Passenger Load	Utilization	Total Capacity	TOTAL Future No Action Bus Passenger Load	Additional MIMP (4-hr period)	Total Future Action Bus Passenger Load	Utilization	
PM	345_S_PM	345	Shoreline/	S	444	84	19%	4	30%	444	34	118	16	134	30%	32	30%	444	134	128	262	59%
	345_N_PM	345	Northgate	N	407	101	25%	4	30%	407	41	142	16	158	39%	32	30%	407	142	128	270	66%
	346_S_PM	346	Shoreline/	S	407	102	25%	1	5%	407	41	143	4	147	36%	5	5%	407	143	20	163	40%
	346_N_PM		Northgate	N	370	114	31%	1	5%	370	46	160	4	164	44%	5	5%	370	160	20	180	49%
	40_S_PM	40	Downtown/	S	1,672	255	15%	1	8%	1,672	102	357	4	361	22%	7	8%	1,672	357	28	385	23%
	40_N_PM		Ballard/DT	N	1,672	202	12%	1	8%	1,672	81	283	4	287	17%	8	8%	1,672	283	32	315	19%
	675_N_PM	675	Shoreline/D	N	2,808	727	26%	1	8%	2,808	291	1018	4	1,022	36%	8	8%	2,808	1,018	32	1,050	37%
	675_S_PM		T	S	2,028	546	27%	1	8%	2,028	219	765	4	769	38%	8	8%	2,028	765	32	797	39%
								14									56					

Appendix G Signal Warrants

Warrants Summary												
Information												
Analyst	Transpo Group					Intersection	Meridian Ave N/N 115th St					
Agency/Co						Jurisdiction	SDOT					
Date Performed	5/31/2023					Units	U.S. Customary					
Project ID	UWMC NW TDR					Time Period Analyzed	PM Peak Hour					
East/West Street	N 115th St					North/South Street	Meridian Ave N					
File Name	Warrants1					Major Street	North-South					
Project Description <i>UWMC NW TDR</i>												
General						Roadway Network						
Major Street Speed (mph)	25	<input type="checkbox"/>	Population < 10,000				Two Major Routes			<input type="checkbox"/>		
Nearest Signal (ft)	1330	<input type="checkbox"/>	Coordinated Signal System				Weekend Count			<input type="checkbox"/>		
Crashes (per year)	1	<input type="checkbox"/>	Adequate Trials of Alternatives				5-yr Growth Factor			0		
Geometry and Traffic	EB			WB			NB			SB		
	LT	TH	RT	LT	TH	RT	LT	TH	RT	LT	TH	RT
Number of lanes, N	0	1	0	0	1	0	1	1	0	0	1	0
Lane usage	LTR			LTR			L	TR		LTR		
Vehicle Volume Averages (vph)	195	14	375	7	3	3	228	225	7	3	107	63
Peds (ped/h) / Gaps (gaps/h)	--	0 / 0	--	--	0 / 0	--	--	0 / 0	--	--	0 / 0	--
Delay (s/veh) / (veh-hr)	--	0 / 0	--	--	0 / 0	--	--	0 / 0	--	--	0 / 0	--
Warrant 1: Eight-Hour Vehicular Volume												<input type="checkbox"/>
1 A. Minimum Vehicular Volumes (Both major approaches --and-- higher minor approach) --or--												<input type="checkbox"/>
1 B. Interruption of Continuous Traffic (Both major approaches --and-- higher minor approach) --or--												<input type="checkbox"/>
1 (80%) Vehicular --and-- Interruption Volumes (Both major approaches --and-- higher minor approach)												<input type="checkbox"/>
Warrant 2: Four-Hour Vehicular Volume												<input checked="" type="checkbox"/>
2 A. Four-Hour Vehicular Volumes (Both major approaches --and-- higher minor approach)												<input checked="" type="checkbox"/>
Warrant 3: Peak Hour												<input checked="" type="checkbox"/>
3 A. Peak-Hour Conditions (Minor delay --and-- minor volume --and-- total volume) --or--												<input type="checkbox"/>
3 B. Peak- Hour Vehicular Volumes (Both major approaches --and-- higher minor approach)												<input checked="" type="checkbox"/>
Warrant 4: Pedestrian Volume												<input type="checkbox"/>
4 A. Four Hour Volumes --or--												<input type="checkbox"/>
4 B. One-Hour Volumes												<input type="checkbox"/>
Warrant 5: School Crossing												<input type="checkbox"/>
5. Student Volumes --and--												<input type="checkbox"/>
5. Gaps Same Period												<input type="checkbox"/>
Warrant 6: Coordinated Signal System												<input type="checkbox"/>
6. Degree of Platooning (Predominant direction or both directions)												<input type="checkbox"/>
Warrant 7: Crash Experience												<input type="checkbox"/>
7 A. Adequate trials of alternatives, observance and enforcement failed --and--												<input type="checkbox"/>
7 B. Reported crashes susceptible to correction by signal (12-month period) --and--												<input type="checkbox"/>
7 C. (80%) Volumes for Warrants 1A, 1B --or-- 4 are satisfied												<input checked="" type="checkbox"/>

Warrant 8: Roadway Network	<input type="checkbox"/>
8 A. Weekday Volume (Peak hour total --and-- projected warrants 1, 2 or 3) --or--	<input type="checkbox"/>
8 B. Weekend Volume (Five hours total)	<input type="checkbox"/>
Warrant 9: Grade Crossing	<input type="checkbox"/>
9 A. Grade Crossing within 140 ft --and--	<input type="checkbox"/>
9 B. Peak-Hour Vehicular Volumes	<input type="checkbox"/>

Warrants Summary												
Information												
Analyst	Transpo Group					Intersection	Central Access/N 115th St					
Agency/Co						Jurisdiction	SDOT					
Date Performed	5/31/2023					Units	U.S. Customary					
Project ID	UWMC NW TDR					Time Period Analyzed	PM Peak Hour					
East/West Street	N 115th Street					North/South Street	Central Access					
File Name	Central Access_115th Warrants.xhy					Major Street	East-West					
Project Description <i>UWMC NW TDR</i>												
General						Roadway Network						
Major Street Speed (mph)	25	<input type="checkbox"/>	Population < 10,000			Two Major Routes			<input type="checkbox"/>			
Nearest Signal (ft)	1900	<input type="checkbox"/>	Coordinated Signal System			Weekend Count			<input type="checkbox"/>			
Crashes (per year)	2	<input type="checkbox"/>	Adequate Trials of Alternatives			5-yr Growth Factor			0			
Geometry and Traffic	EB			WB			NB			SB		
	LT	TH	RT	LT	TH	RT	LT	TH	RT	LT	TH	RT
Number of lanes, N	1	1	0	0	1	0	0	0	0	0	0	0
Lane usage	L	T			TR						LR	
Vehicle Volume Averages (vph)	15	263	0	0	300	30	0	0	0	225	0	67
Peds (ped/h) / Gaps (gaps/h)	--	0 / 0	--	--	0 / 0	--	--	0 / 0	--	--	0 / 0	--
Delay (s/veh) / (veh-hr)	--	0 / 0	--	--	0 / 0	--	--	0 / 0	--	--	0 / 0	--
Warrant 1: Eight-Hour Vehicular Volume												<input type="checkbox"/>
1 A. Minimum Vehicular Volumes (Both major approaches --and-- higher minor approach) --or--												<input type="checkbox"/>
1 B. Interruption of Continuous Traffic (Both major approaches --and-- higher minor approach) --or--												<input type="checkbox"/>
1 (80%) Vehicular --and-- Interruption Volumes (Both major approaches --and-- higher minor approach)												<input type="checkbox"/>
Warrant 2: Four-Hour Vehicular Volume												<input checked="" type="checkbox"/>
2 A. Four-Hour Vehicular Volumes (Both major approaches --and-- higher minor approach)												<input checked="" type="checkbox"/>
Warrant 3: Peak Hour												<input checked="" type="checkbox"/>
3 A. Peak-Hour Conditions (Minor delay --and-- minor volume --and-- total volume) --or--												<input type="checkbox"/>
3 B. Peak- Hour Vehicular Volumes (Both major approaches --and-- higher minor approach)												<input checked="" type="checkbox"/>
Warrant 4: Pedestrian Volume												<input type="checkbox"/>
4 A. Four Hour Volumes --or--												<input type="checkbox"/>
4 B. One-Hour Volumes												<input type="checkbox"/>
Warrant 5: School Crossing												<input type="checkbox"/>
5. Student Volumes --and--												<input type="checkbox"/>
5. Gaps Same Period												<input type="checkbox"/>
Warrant 6: Coordinated Signal System												<input type="checkbox"/>
6. Degree of Platooning (Predominant direction or both directions)												<input type="checkbox"/>
Warrant 7: Crash Experience												<input type="checkbox"/>
7 A. Adequate trials of alternatives, observance and enforcement failed --and--												<input type="checkbox"/>
7 B. Reported crashes susceptible to correction by signal (12-month period) --and--												<input type="checkbox"/>

7 C. (80%) Volumes for Warrants 1A, 1B --or-- 4 are satisfied	<input checked="" type="checkbox"/>
Warrant 8: Roadway Network	<input type="checkbox"/>
8 A. Weekday Volume (Peak hour total --and-- projected warrants 1, 2 or 3) --or--	<input type="checkbox"/>
8 B. Weekend Volume (Five hours total)	<input type="checkbox"/>
Warrant 9: Grade Crossing	<input type="checkbox"/>
9 A. Grade Crossing within 140 ft --and--	<input type="checkbox"/>
9 B. Peak-Hour Vehicular Volumes	<input type="checkbox"/>

Appendix H Access Analysis

Alternative 1 2030 Weekday AM Peak Hour Site Access LOS Access Summary

Intersection	Traffic Control	No Action				Evenly Distributed Parking Scenario				West Concentrated Parking Scenario			
		LOS ¹	Delay ²	WM ³	Queue ⁴	LOS	Delay	WM	Queue	LOS	Delay	WM	Queue
Option 1 - N 115th St													
10. Meridian Ave N/N 120th St	TWSC	B	14	WB	-	C	18	WB	-	C	18	WB	-
A. West Access/N 115th St	TWSC	C	20	SBL	1	C	24	SBL	1	E	37	SBL	4
B. East Access/N 115th St	TWSC	D	30	SBL	2	F	76	SBL	4	F	88	SBL	6
C. Central Access/N 115th St	Signal	-	-	-	-	A	7	-	-	A	8	-	-
Option 2 - N 120th St													
10. Meridian Ave N/N 120th St	TWSC	B	14	WB	-	C	20	WB	-	C	20	WB	-
A. West Access/N 115th St	TWSC	C	20	SBL	1	E	37	SBL	3	F	76	SBL	6
B. East Access/N 115th St	TWSC	D	30	SBL	2	F	254	SBL	12	F	188	SBL	8
D. North Access/N 120th St	TWSC	-	-	-	-	A	9	NB	<1	A	9	NB	<1

Note: TWSC = Two-Way Stop Controlled. **Bold** text indicates operating at LOS E or F if signalized or LOS F for TWSC.

1. Level of Service (A – F) as defined by the *Highway Capacity Manual* (HCM) 6th Edition (TRB, 2016).
2. Average delay per vehicle in seconds
3. Worst movement reported for TWSC intersections. WB = westbound, SBL = southbound left-turn.
4. 95th percentile queue (vehicles) reported for the worst movement at the stop-controlled site access points.

Alternative 1 2030 Weekday PM Peak Hour Site Access LOS Access Summary

Intersection	Traffic Control	No Action				Evenly Distributed Parking Scenario				West Concentrated Parking Scenario			
		LOS ¹	Delay ²	WM ³	Queue ⁴	LOS	Delay	WM	Queue	LOS	Delay	WM	Queue
Option 1 - N 115th St													
10. Meridian Ave N/N 120th St	TWSC	B	15	WB	-	C	18	WB	-	C	18	WB	-
A. West Access/N 115th St	TWSC	C	21	SBL	2	D	27	SBL	2	E	39	SBL	4
B. East Access/N 115th St	TWSC	D	30	SBL	4	F	94	SBL	7	F	92	SBL	7
C. Central Access/N 115th St	Signal	-	-	-	-	A	9	-	-	A	8	-	-
Option 2 - N 120th St													
10. Meridian Ave N/N 120th St	TWSC	B	15	WB	-	C	18	WB	-	C	18	WB	-
A. West Access/N 115th St	TWSC	C	21	SBL	2	D	29	SBL	3	F	122	SBL	13
B. East Access/N 115th St	TWSC	D	30	SBL	4	F	228	SBL	18	F	185	SBL	14
D. North Access/N 120th St	TWSC	-	-	-	-	A	9	NB	<1	A	9	NB	<1

Note: TWSC = Two-Way Stop Controlled. **Bold** text indicates operating at LOS E or F if signalized or LOS F for TWSC.

1. Level of Service (A – F) as defined by the *Highway Capacity Manual* (HCM) 6th Edition (TRB, 2016).
2. Average delay per vehicle in seconds
3. Worst movement reported for TWSC intersections. WB = westbound, SBL = southbound left-turn, EB = eastbound.
4. 95th percentile queue reported for the worst movement at the stop-controlled site access points.

Alternative 1 2040 Weekday AM Peak Hour Site Access LOS Access Summary

Intersection	Traffic Control	No Action				Evenly Distributed Parking Scenario				West Concentrated Parking Scenario			
		LOS ¹	Delay ²	WM ³	Queue ⁴	LOS	Delay	WM	Queue	LOS	Delay	WM	Queue
Option 1 - N 115th St													
10. Meridian Ave N/N 120th St	TWSC	B	13	WB	-	C	17	WB	-	C	17	WB	-
A. West Access/N 115th St	TWSC	C	17	SBL	1	C	22	SBL	1	D	27	SBL	2
B. East Access/N 115th St	TWSC	C	23	SBL	1	F	56	SBL	3	F	54	SBL	3
C. Central Access/N 115th St	Signal	-	-	-	-	A	7	-	-	A	9	-	-
Option 2 - N 120th St													
10. Meridian Ave N/N 120th St	TWSC	B	13	WB	-	C	18	WB	-	C	18	WB	-
A. West Access/N 115th St	TWSC	C	17	SBL	1	D	32	SBL	2	F	54	SBL	5
B. East Access/N 115th St	TWSC	C	23	SBL	1	F	170	SBL	10	F	120	SBL	6
D. North Access/N 120th St	TWSC	-	-	-	-	A	9	NB	<1	A	9	NB	<1

Note: TWSC = Two-Way Stop Controlled. **Bold** text indicates operating at LOS E or F if signalized or LOS F for TWSC.

1. Level of Service (A – F) as defined by the *Highway Capacity Manual* (HCM) 6th Edition (TRB, 2016).
2. Average delay per vehicle in seconds
3. Worst movement reported for TWSC intersections. WB = westbound, SBL = southbound left-turn, EB = eastbound.
4. 95th percentile queue reported for the worst movement at the stop-controlled site access points.

Alternative 1 2040 Weekday PM Peak Hour Site Access LOS Access Summary

Intersection	Traffic Control	No Action				Evenly Distributed Parking Scenario				West Concentrated Parking Scenario			
		LOS ¹	Delay ²	WM ³	Queue ⁴	LOS	Delay	WM	Queue	LOS	Delay	WM	Queue
Option 1 - N 115th St													
10. Meridian Ave N/N 120th St	TWSC	B	14	WB	-	C	17	WB	-	C	17	WB	-
A. West Access/N 115th St	TWSC	C	19	SBL	1	C	24	SBL	2	D	33	SBL	3
B. East Access/N 115th St	TWSC	D	26	SBL	3	F	70	SBL	5	F	69	SBL	5
C. Central Access/N 115th St	Signal	-	-	-	-	A	9	-	-	A	8	-	-
Option 2 - N 120th St													
10. Meridian Ave N/N 120th St	TWSC	B	14	WB	-	C	17	EB	-	C	17	EB	-
A. West Access/N 115th St	TWSC	C	19	SBL	1	D	34	SBL	4	F	88	SBL	10
B. East Access/N 115th St	TWSC	D	26	SBL	3	F	212	SBL	18	F	132	SBL	11
D. North Access/N 120th St	TWSC	-	-	-	-	A	9	NB	<1	A	9	NB	<1

Note: TWSC = Two-Way Stop Controlled. **Bold** text indicates operating at LOS E or F if signalized or LOS F for TWSC.

1. Level of Service (A – F) as defined by the *Highway Capacity Manual* (HCM) 6th Edition (TRB, 2016).
2. Average delay per vehicle in seconds
3. Worst movement reported for TWSC intersections. WB = westbound, SBL = southbound left-turn, EB = eastbound.
4. 95th percentile queue reported for the worst movement at the stop-controlled site access points.

Intersection												
Int Delay, s/veh	2.4											
Movement	EBL	EBT	EBR	WBL	WBT	WBR	NBL	NBT	NBR	SBL	SBT	SBR
Lane Configurations		↕			↕			↕			↕	
Traffic Vol, veh/h	5	5	50	11	5	10	70	406	31	5	152	5
Future Vol, veh/h	5	5	50	11	5	10	70	406	31	5	152	5
Conflicting Peds, #/hr	1	0	4	4	0	1	1	0	12	12	0	1
Sign Control	Stop	Stop	Stop	Stop	Stop	Stop	Free	Free	Free	Free	Free	Free
RT Channelized	-	-	None	-	-	None	-	-	None	-	-	None
Storage Length	-	-	-	-	-	-	-	-	-	-	-	-
Veh in Median Storage, #	-	0	-	-	0	-	-	0	-	-	0	-
Grade, %	-	0	-	-	0	-	-	0	-	-	0	-
Peak Hour Factor	86	86	86	86	86	86	86	86	86	86	86	86
Heavy Vehicles, %	13	13	13	0	0	0	10	10	10	4	4	4
Mvmt Flow	6	6	58	13	6	12	81	472	36	6	177	6

Major/Minor	Minor2		Minor1		Major1			Major2				
Conflicting Flow All	855	875	185	892	860	503	184	0	0	520	0	0
Stage 1	193	193	-	664	664	-	-	-	-	-	-	-
Stage 2	662	682	-	228	196	-	-	-	-	-	-	-
Critical Hdwy	7.23	6.63	6.33	7.1	6.5	6.2	4.2	-	-	4.14	-	-
Critical Hdwy Stg 1	6.23	5.63	-	6.1	5.5	-	-	-	-	-	-	-
Critical Hdwy Stg 2	6.23	5.63	-	6.1	5.5	-	-	-	-	-	-	-
Follow-up Hdwy	3.617	4.117	3.417	3.5	4	3.3	2.29	-	-	2.236	-	-
Pot Cap-1 Maneuver	266	276	830	265	296	573	1344	-	-	1036	-	-
Stage 1	784	721	-	453	461	-	-	-	-	-	-	-
Stage 2	433	433	-	779	742	-	-	-	-	-	-	-
Platoon blocked, %								-	-	-	-	-
Mov Cap-1 Maneuver	238	248	826	222	266	566	1343	-	-	1024	-	-
Mov Cap-2 Maneuver	238	248	-	222	266	-	-	-	-	-	-	-
Stage 1	717	715	-	410	417	-	-	-	-	-	-	-
Stage 2	382	392	-	711	736	-	-	-	-	-	-	-

Approach	EB		WB		NB		SB	
HCM Control Delay, s	11.9		18.2		1.1		0.3	
HCM LOS	B		C					

Minor Lane/Major Mvmt	NBL	NBT	NBR	EBLn1WBLn1	SBL	SBT	SBR
Capacity (veh/h)	1343	-	-	590	302	1024	-
HCM Lane V/C Ratio	0.061	-	-	0.118	0.1	0.006	-
HCM Control Delay (s)	7.9	0	-	11.9	18.2	8.5	0
HCM Lane LOS	A	A	-	B	C	A	A
HCM 95th %tile Q(veh)	0.2	-	-	0.4	0.3	0	-

Intersection						
Int Delay, s/veh	6.9					
Movement	EBL	EBT	WBT	WBR	SBL	SBR
Lane Configurations		↕	↕		↕	↕
Traffic Vol, veh/h	20	282	482	37	164	75
Future Vol, veh/h	20	282	482	37	164	75
Conflicting Peds, #/hr	18	0	0	18	0	0
Sign Control	Free	Free	Free	Free	Stop	Stop
RT Channelized	-	None	-	None	-	None
Storage Length	-	-	-	-	0	0
Veh in Median Storage, #	-	0	0	-	0	-
Grade, %	-	0	0	-	0	-
Peak Hour Factor	91	91	91	91	91	91
Heavy Vehicles, %	5	5	9	9	0	0
Mvmt Flow	22	310	530	41	180	82

Major/Minor	Major1	Major2	Minor2		
Conflicting Flow All	589	0	-	0	923
Stage 1	-	-	-	-	569
Stage 2	-	-	-	-	354
Critical Hdwy	4.15	-	-	-	6.4
Critical Hdwy Stg 1	-	-	-	-	5.4
Critical Hdwy Stg 2	-	-	-	-	5.4
Follow-up Hdwy	2.245	-	-	-	3.5
Pot Cap-1 Maneuver	972	-	-	-	302
Stage 1	-	-	-	-	570
Stage 2	-	-	-	-	715
Platoon blocked, %		-	-	-	
Mov Cap-1 Maneuver	955	-	-	-	284
Mov Cap-2 Maneuver	-	-	-	-	284
Stage 1	-	-	-	-	544
Stage 2	-	-	-	-	703

Approach	EB	WB	SB
HCM Control Delay, s	0.6	0	29.8
HCM LOS			D

Minor Lane/Major Mvmt	EBL	EBT	WBT	WBR	SBLn1	SBLn2
Capacity (veh/h)	955	-	-	-	284	516
HCM Lane V/C Ratio	0.023	-	-	-	0.635	0.16
HCM Control Delay (s)	8.9	0	-	-	37.3	13.3
HCM Lane LOS	A	A	-	-	E	B
HCM 95th %tile Q(veh)	0.1	-	-	-	4	0.6

Intersection						
Int Delay, s/veh	10.3					
Movement	EBL	EBT	WBT	WBR	SBL	SBR
Lane Configurations		↶	↷		↶	↷
Traffic Vol, veh/h	17	682	376	46	144	81
Future Vol, veh/h	17	682	376	46	144	81
Conflicting Peds, #/hr	18	0	0	18	0	0
Sign Control	Free	Free	Free	Free	Stop	Stop
RT Channelized	-	None	-	None	-	None
Storage Length	-	-	-	-	0	0
Veh in Median Storage, #	-	0	0	-	0	-
Grade, %	-	0	0	-	0	-
Peak Hour Factor	91	91	91	91	91	91
Heavy Vehicles, %	5	5	9	9	0	0
Mvmt Flow	19	749	413	51	158	89

Major/Minor	Major1	Major2	Minor2		
Conflicting Flow All	482	0	-	0	1244 457
Stage 1	-	-	-	-	457 -
Stage 2	-	-	-	-	787 -
Critical Hdwy	4.15	-	-	-	6.4 6.2
Critical Hdwy Stg 1	-	-	-	-	5.4 -
Critical Hdwy Stg 2	-	-	-	-	5.4 -
Follow-up Hdwy	2.245	-	-	-	3.5 3.3
Pot Cap-1 Maneuver	1065	-	-	-	194 608
Stage 1	-	-	-	-	642 -
Stage 2	-	-	-	-	452 -
Platoon blocked, %		-	-	-	
Mov Cap-1 Maneuver	1047	-	-	-	182 598
Mov Cap-2 Maneuver	-	-	-	-	182 -
Stage 1	-	-	-	-	612 -
Stage 2	-	-	-	-	444 -

Approach	EB	WB	SB
HCM Control Delay, s	0.2	0	60.8
HCM LOS			F

Minor Lane/Major Mvmt	EBL	EBT	WBT	WBR	SBLn1	SBLn2
Capacity (veh/h)	1047	-	-	-	182	598
HCM Lane V/C Ratio	0.018	-	-	-	0.869	0.149
HCM Control Delay (s)	8.5	0	-	-	88.2	12.1
HCM Lane LOS	A	A	-	-	F	B
HCM 95th %tile Q(veh)	0.1	-	-	-	6.4	0.5

HCM 6th Signalized Intersection Summary

UWMC - NW

15: N 115th St & Central Site Access (Future) Future With-Project (2030) AM Peak Hour_Access Parking (west weighted)



Movement	EBL	EBT	WBT	WBR	SBL	SBR
Lane Configurations						
Traffic Volume (veh/h)	31	424	398	54	279	120
Future Volume (veh/h)	31	424	398	54	279	120
Initial Q (Qb), veh	0	0	0	0	0	0
Ped-Bike Adj(A_pbT)	0.99			0.97	1.00	1.00
Parking Bus, Adj	1.00	1.00	1.00	1.00	1.00	1.00
Work Zone On Approach		No	No		No	
Adj Sat Flow, veh/h/ln	1826	1826	1767	1767	1900	1900
Adj Flow Rate, veh/h	34	466	437	59	307	132
Peak Hour Factor	0.91	0.91	0.91	0.91	0.91	0.91
Percent Heavy Veh, %	5	5	9	9	0	0
Cap, veh/h	431	808	671	91	462	412
Arrive On Green	0.44	0.44	0.44	0.44	0.26	0.26
Sat Flow, veh/h	876	1826	1516	205	1810	1610
Grp Volume(v), veh/h	34	466	0	496	307	132
Grp Sat Flow(s),veh/h/ln	876	1826	0	1721	1810	1610
Q Serve(g_s), s	0.9	5.7	0.0	6.7	4.5	2.0
Cycle Q Clear(g_c), s	7.7	5.7	0.0	6.7	4.5	2.0
Prop In Lane	1.00			0.12	1.00	1.00
Lane Grp Cap(c), veh/h	431	808	0	762	462	412
V/C Ratio(X)	0.08	0.58	0.00	0.65	0.66	0.32
Avail Cap(c_a), veh/h	1116	2235	0	2107	1487	1323
HCM Platoon Ratio	1.00	1.00	1.00	1.00	1.00	1.00
Upstream Filter(I)	1.00	1.00	0.00	1.00	1.00	1.00
Uniform Delay (d), s/veh	9.5	6.2	0.0	6.5	9.9	9.0
Incr Delay (d2), s/veh	0.1	0.7	0.0	0.9	1.6	0.4
Initial Q Delay(d3),s/veh	0.0	0.0	0.0	0.0	0.0	0.0
%ile BackOfQ(50%),veh/ln	0.1	1.2	0.0	1.4	1.4	0.5
Unsig. Movement Delay, s/veh						
LnGrp Delay(d),s/veh	9.6	6.9	0.0	7.5	11.6	9.4
LnGrp LOS	A	A	A	A	B	A
Approach Vol, veh/h		500	496		439	
Approach Delay, s/veh		7.1	7.5		10.9	
Approach LOS		A	A		B	
Timer - Assigned Phs				4	6	8
Phs Duration (G+Y+Rc), s				17.7	12.1	17.7
Change Period (Y+Rc), s				4.5	4.5	4.5
Max Green Setting (Gmax), s				36.5	24.5	36.5
Max Q Clear Time (g_c+I1), s				9.7	6.5	8.7
Green Ext Time (p_c), s				3.4	1.3	3.5
Intersection Summary						
HCM 6th Ctrl Delay			8.4			
HCM 6th LOS			A			
Notes						
User approved volume balancing among the lanes for turning movement.						

Intersection												
Int Delay, s/veh	2.3											
Movement	EBL	EBT	EBR	WBL	WBT	WBR	NBL	NBT	NBR	SBL	SBT	SBR
Lane Configurations		↕			↕			↕			↕	
Traffic Vol, veh/h	5	5	50	11	5	10	70	406	31	5	152	5
Future Vol, veh/h	5	5	50	11	5	10	70	406	31	5	152	5
Conflicting Peds, #/hr	0	0	7	7	0	0	0	0	8	8	0	0
Sign Control	Stop	Stop	Stop	Stop	Stop	Stop	Free	Free	Free	Free	Free	Free
RT Channelized	-	-	None	-	-	None	-	-	None	-	-	None
Storage Length	-	-	-	-	-	-	-	-	-	-	-	-
Veh in Median Storage, #	-	0	-	-	0	-	-	0	-	-	0	-
Grade, %	-	0	-	-	0	-	-	0	-	-	0	-
Peak Hour Factor	89	89	89	89	89	89	89	89	89	89	89	89
Heavy Vehicles, %	9	9	9	5	5	5	2	2	2	6	6	6
Mvmt Flow	6	6	56	12	6	11	79	456	35	6	171	6

Major/Minor	Minor2		Minor1		Major1			Major2				
Conflicting Flow All	826	843	181	864	829	482	177	0	0	499	0	0
Stage 1	186	186	-	640	640	-	-	-	-	-	-	-
Stage 2	640	657	-	224	189	-	-	-	-	-	-	-
Critical Hdwy	7.19	6.59	6.29	7.15	6.55	6.25	4.12	-	-	4.16	-	-
Critical Hdwy Stg 1	6.19	5.59	-	6.15	5.55	-	-	-	-	-	-	-
Critical Hdwy Stg 2	6.19	5.59	-	6.15	5.55	-	-	-	-	-	-	-
Follow-up Hdwy	3.581	4.081	3.381	3.545	4.045	3.345	2.218	-	-	2.254	-	-
Pot Cap-1 Maneuver	283	293	844	271	303	578	1399	-	-	1045	-	-
Stage 1	800	733	-	459	465	-	-	-	-	-	-	-
Stage 2	452	451	-	772	738	-	-	-	-	-	-	-
Platoon blocked, %								-	-	-	-	-
Mov Cap-1 Maneuver	256	266	838	230	275	574	1399	-	-	1037	-	-
Mov Cap-2 Maneuver	256	266	-	230	275	-	-	-	-	-	-	-
Stage 1	738	729	-	420	425	-	-	-	-	-	-	-
Stage 2	403	413	-	706	734	-	-	-	-	-	-	-

Approach	EB		WB		NB		SB	
HCM Control Delay, s	11.6		17.7		1.1		0.3	
HCM LOS	B		C					

Minor Lane/Major Mvmt	NBL	NBT	NBR	EBLn1	WBLn1	SBL	SBT	SBR
Capacity (veh/h)	1399	-	-	612	312	1037	-	-
HCM Lane V/C Ratio	0.056	-	-	0.11	0.094	0.005	-	-
HCM Control Delay (s)	7.7	0	-	11.6	17.7	8.5	0	-
HCM Lane LOS	A	A	-	B	C	A	A	-
HCM 95th %tile Q(veh)	0.2	-	-	0.4	0.3	0	-	-

Intersection						
Int Delay, s/veh	7.1					
Movement	EBL	EBT	WBT	WBR	SBL	SBR
Lane Configurations		↔	↔		↔	↔
Traffic Vol, veh/h	20	282	482	37	164	75
Future Vol, veh/h	20	282	482	37	164	75
Conflicting Peds, #/hr	23	0	0	23	0	0
Sign Control	Free	Free	Free	Free	Stop	Stop
RT Channelized	-	None	-	None	-	None
Storage Length	-	-	-	-	0	0
Veh in Median Storage, #	-	0	0	-	0	-
Grade, %	-	0	0	-	0	-
Peak Hour Factor	91	91	91	91	91	91
Heavy Vehicles, %	2	2	6	6	0	0
Mvmt Flow	22	310	530	41	180	82

Major/Minor	Major1	Major2	Minor2		
Conflicting Flow All	594	0	-	0	928
Stage 1	-	-	-	-	574
Stage 2	-	-	-	-	354
Critical Hdwy	4.12	-	-	-	6.4
Critical Hdwy Stg 1	-	-	-	-	5.4
Critical Hdwy Stg 2	-	-	-	-	5.4
Follow-up Hdwy	2.218	-	-	-	3.5
Pot Cap-1 Maneuver	982	-	-	-	300
Stage 1	-	-	-	-	567
Stage 2	-	-	-	-	715
Platoon blocked, %		-	-	-	
Mov Cap-1 Maneuver	960	-	-	-	279
Mov Cap-2 Maneuver	-	-	-	-	279
Stage 1	-	-	-	-	539
Stage 2	-	-	-	-	699

Approach	EB	WB	SB
HCM Control Delay, s	0.6	0	30.8
HCM LOS			D

Minor Lane/Major Mvmt	EBL	EBT	WBT	WBR	SBLn1	SBLn2
Capacity (veh/h)	960	-	-	-	279	511
HCM Lane V/C Ratio	0.023	-	-	-	0.646	0.161
HCM Control Delay (s)	8.8	0	-	-	38.7	13.4
HCM Lane LOS	A	A	-	-	E	B
HCM 95th %tile Q(veh)	0.1	-	-	-	4.1	0.6

Intersection						
Int Delay, s/veh	10.7					
Movement	EBL	EBT	WBT	WBR	SBL	SBR
Lane Configurations		↕	↕		↕	↕
Traffic Vol, veh/h	17	682	376	46	144	81
Future Vol, veh/h	17	682	376	46	144	81
Conflicting Peds, #/hr	23	0	0	23	0	0
Sign Control	Free	Free	Free	Free	Stop	Stop
RT Channelized	-	None	-	None	-	None
Storage Length	-	-	-	-	0	0
Veh in Median Storage, #	-	0	0	-	0	-
Grade, %	-	0	0	-	0	-
Peak Hour Factor	91	91	91	91	91	91
Heavy Vehicles, %	2	2	6	6	0	0
Mvmt Flow	19	749	413	51	158	89
Major/Minor	Major1	Major2	Minor2			
Conflicting Flow All	487	0	-	0	1249	462
Stage 1	-	-	-	-	462	-
Stage 2	-	-	-	-	787	-
Critical Hdwy	4.12	-	-	-	6.4	6.2
Critical Hdwy Stg 1	-	-	-	-	5.4	-
Critical Hdwy Stg 2	-	-	-	-	5.4	-
Follow-up Hdwy	2.218	-	-	-	3.5	3.3
Pot Cap-1 Maneuver	1076	-	-	-	193	604
Stage 1	-	-	-	-	638	-
Stage 2	-	-	-	-	452	-
Platoon blocked, %		-	-	-		
Mov Cap-1 Maneuver	1052	-	-	-	179	591
Mov Cap-2 Maneuver	-	-	-	-	179	-
Stage 1	-	-	-	-	605	-
Stage 2	-	-	-	-	442	-
Approach	EB	WB	SB			
HCM Control Delay, s	0.2	0	63.4			
HCM LOS			F			
Minor Lane/Major Mvmt	EBL	EBT	WBT	WBR	SBLn1	SBLn2
Capacity (veh/h)	1052	-	-	-	179	591
HCM Lane V/C Ratio	0.018	-	-	-	0.884	0.151
HCM Control Delay (s)	8.5	0	-	-	92.2	12.2
HCM Lane LOS	A	A	-	-	F	B
HCM 95th %tile Q(veh)	0.1	-	-	-	6.5	0.5

HCM 6th Signalized Intersection Summary

UWMC - NW

15: N 115th St & Central Site Access (Future) Future With-Project (2030) PM Peak Hour_Access Parking (west weighted)



Movement	EBL	EBT	WBT	WBR	SBL	SBR
Lane Configurations						
Traffic Volume (veh/h)	31	424	398	54	279	120
Future Volume (veh/h)	31	424	398	54	279	120
Initial Q (Qb), veh	0	0	0	0	0	0
Ped-Bike Adj(A_pbT)	0.99			0.98	1.00	1.00
Parking Bus, Adj	1.00	1.00	1.00	1.00	1.00	1.00
Work Zone On Approach		No	No		No	
Adj Sat Flow, veh/h/ln	1870	1870	1811	1811	1900	1900
Adj Flow Rate, veh/h	34	466	437	59	307	132
Peak Hour Factor	0.91	0.91	0.91	0.91	0.91	0.91
Percent Heavy Veh, %	2	2	6	6	0	0
Cap, veh/h	442	825	687	93	463	412
Arrive On Green	0.44	0.44	0.44	0.44	0.26	0.26
Sat Flow, veh/h	896	1870	1559	210	1810	1610
Grp Volume(v), veh/h	34	466	0	496	307	132
Grp Sat Flow(s),veh/h/ln	896	1870	0	1769	1810	1610
Q Serve(g_s), s	0.9	5.5	0.0	6.5	4.5	2.0
Cycle Q Clear(g_c), s	7.4	5.5	0.0	6.5	4.5	2.0
Prop In Lane	1.00			0.12	1.00	1.00
Lane Grp Cap(c), veh/h	442	825	0	780	463	412
V/C Ratio(X)	0.08	0.57	0.00	0.64	0.66	0.32
Avail Cap(c_a), veh/h	1149	2300	0	2176	1494	1329
HCM Platoon Ratio	1.00	1.00	1.00	1.00	1.00	1.00
Upstream Filter(I)	1.00	1.00	0.00	1.00	1.00	1.00
Uniform Delay (d), s/veh	9.3	6.2	0.0	6.4	9.9	9.0
Incr Delay (d2), s/veh	0.1	0.6	0.0	0.9	1.6	0.4
Initial Q Delay(d3),s/veh	0.0	0.0	0.0	0.0	0.0	0.0
%ile BackOfQ(50%),veh/ln	0.1	1.2	0.0	1.4	1.4	0.5
Unsig. Movement Delay, s/veh						
LnGrp Delay(d),s/veh	9.4	6.8	0.0	7.3	11.5	9.4
LnGrp LOS	A	A	A	A	B	A
Approach Vol, veh/h		500	496		439	
Approach Delay, s/veh		7.0	7.3		10.9	
Approach LOS		A	A		B	
Timer - Assigned Phs				4	6	8
Phs Duration (G+Y+Rc), s				17.6	12.1	17.6
Change Period (Y+Rc), s				4.5	4.5	4.5
Max Green Setting (Gmax), s				36.5	24.5	36.5
Max Q Clear Time (g_c+I1), s				9.4	6.5	8.5
Green Ext Time (p_c), s				3.4	1.3	3.5
Intersection Summary						
HCM 6th Ctrl Delay			8.3			
HCM 6th LOS			A			
Notes						
User approved volume balancing among the lanes for turning movement.						

Intersection												
Int Delay, s/veh	2.8											
Movement	EBL	EBT	EBR	WBL	WBT	WBR	NBL	NBT	NBR	SBL	SBT	SBR
Lane Configurations		↕			↕			↕			↕	
Traffic Vol, veh/h	5	5	75	27	5	5	35	162	16	5	380	5
Future Vol, veh/h	5	5	75	27	5	5	35	162	16	5	380	5
Conflicting Peds, #/hr	1	0	4	4	0	1	1	0	12	12	0	1
Sign Control	Stop	Stop	Stop	Stop	Stop	Stop	Free	Free	Free	Free	Free	Free
RT Channelized	-	-	None	-	-	None	-	-	None	-	-	None
Storage Length	-	-	-	-	-	-	-	-	-	-	-	-
Veh in Median Storage, #	-	0	-	-	0	-	-	0	-	-	0	-
Grade, %	-	0	-	-	0	-	-	0	-	-	0	-
Peak Hour Factor	100	100	100	100	100	100	100	100	100	100	100	100
Heavy Vehicles, %	13	13	13	0	0	0	10	10	10	4	4	4
Mvmt Flow	5	5	75	27	5	5	35	162	16	5	380	5

Major/Minor	Minor2		Minor1		Major1		Major2					
Conflicting Flow All	640	654	388	689	648	183	386	0	0	190	0	0
Stage 1	394	394	-	252	252	-	-	-	-	-	-	-
Stage 2	246	260	-	437	396	-	-	-	-	-	-	-
Critical Hdwy	7.23	6.63	6.33	7.1	6.5	6.2	4.2	-	-	4.14	-	-
Critical Hdwy Stg 1	6.23	5.63	-	6.1	5.5	-	-	-	-	-	-	-
Critical Hdwy Stg 2	6.23	5.63	-	6.1	5.5	-	-	-	-	-	-	-
Follow-up Hdwy	3.617	4.117	3.417	3.5	4	3.3	2.29	-	-	2.236	-	-
Pot Cap-1 Maneuver	373	372	637	363	392	865	1130	-	-	1372	-	-
Stage 1	609	587	-	757	702	-	-	-	-	-	-	-
Stage 2	734	673	-	602	607	-	-	-	-	-	-	-
Platoon blocked, %								-	-	-	-	-
Mov Cap-1 Maneuver	355	353	634	303	372	854	1129	-	-	1356	-	-
Mov Cap-2 Maneuver	355	353	-	303	372	-	-	-	-	-	-	-
Stage 1	588	583	-	723	670	-	-	-	-	-	-	-
Stage 2	699	643	-	522	603	-	-	-	-	-	-	-

Approach	EB		WB		NB		SB			
HCM Control Delay, s	12.3		16.8		1.4		0.1			
HCM LOS	B		C							

Minor Lane/Major Mvmt	NBL	NBT	NBR	EBLn1WBLn1	SBL	SBT	SBR
Capacity (veh/h)	1129	-	-	580	341	1356	-
HCM Lane V/C Ratio	0.031	-	-	0.147	0.109	0.004	-
HCM Control Delay (s)	8.3	0	-	12.3	16.8	7.7	0
HCM Lane LOS	A	A	-	B	C	A	A
HCM 95th %tile Q(veh)	0.1	-	-	0.5	0.4	0	-

Intersection						
Int Delay, s/veh	3.3					
Movement	EBL	EBT	WBT	WBR	SBL	SBR
Lane Configurations		↔	↔		↔	↔
Traffic Vol, veh/h	83	437	251	161	87	40
Future Vol, veh/h	83	437	251	161	87	40
Conflicting Peds, #/hr	18	0	0	18	0	0
Sign Control	Free	Free	Free	Free	Stop	Stop
RT Channelized	-	None	-	None	-	None
Storage Length	-	-	-	-	0	0
Veh in Median Storage, #	-	0	0	-	0	-
Grade, %	-	0	0	-	0	-
Peak Hour Factor	100	100	100	100	100	100
Heavy Vehicles, %	5	5	9	9	0	0
Mvmt Flow	83	437	251	161	87	40

Major/Minor	Major1	Major2	Minor2		
Conflicting Flow All	430	0	-	0	953 350
Stage 1	-	-	-	-	350 -
Stage 2	-	-	-	-	603 -
Critical Hdwy	4.15	-	-	-	6.4 6.2
Critical Hdwy Stg 1	-	-	-	-	5.4 -
Critical Hdwy Stg 2	-	-	-	-	5.4 -
Follow-up Hdwy	2.245	-	-	-	3.5 3.3
Pot Cap-1 Maneuver	1114	-	-	-	290 698
Stage 1	-	-	-	-	718 -
Stage 2	-	-	-	-	550 -
Platoon blocked, %		-	-	-	
Mov Cap-1 Maneuver	1095	-	-	-	252 686
Mov Cap-2 Maneuver	-	-	-	-	252 -
Stage 1	-	-	-	-	635 -
Stage 2	-	-	-	-	541 -

Approach	EB	WB	SB
HCM Control Delay, s	1.4	0	21.6
HCM LOS			C

Minor Lane/Major Mvmt	EBL	EBT	WBT	WBR	SBLn1	SBLn2
Capacity (veh/h)	1095	-	-	-	252	686
HCM Lane V/C Ratio	0.076	-	-	-	0.345	0.058
HCM Control Delay (s)	8.6	0	-	-	26.6	10.6
HCM Lane LOS	A	A	-	-	D	B
HCM 95th %tile Q(veh)	0.2	-	-	-	1.5	0.2

Intersection						
Int Delay, s/veh	3.8					
Movement	EBL	EBT	WBT	WBR	SBL	SBR
Lane Configurations		↕	↕		↕	↕
Traffic Vol, veh/h	77	465	566	221	78	43
Future Vol, veh/h	77	465	566	221	78	43
Conflicting Peds, #/hr	18	0	0	18	0	0
Sign Control	Free	Free	Free	Free	Stop	Stop
RT Channelized	-	None	-	None	-	None
Storage Length	-	-	-	-	0	0
Veh in Median Storage, #	-	0	0	-	0	-
Grade, %	-	0	0	-	0	-
Peak Hour Factor	100	100	100	100	100	100
Heavy Vehicles, %	5	5	9	9	0	0
Mvmt Flow	77	465	566	221	78	43

Major/Minor	Major1	Major2	Minor2		
Conflicting Flow All	805	0	-	0	1314 695
Stage 1	-	-	-	-	695 -
Stage 2	-	-	-	-	619 -
Critical Hdwy	4.15	-	-	-	6.4 6.2
Critical Hdwy Stg 1	-	-	-	-	5.4 -
Critical Hdwy Stg 2	-	-	-	-	5.4 -
Follow-up Hdwy	2.245	-	-	-	3.5 3.3
Pot Cap-1 Maneuver	806	-	-	-	176 446
Stage 1	-	-	-	-	499 -
Stage 2	-	-	-	-	541 -
Platoon blocked, %		-	-	-	
Mov Cap-1 Maneuver	792	-	-	-	148 438
Mov Cap-2 Maneuver	-	-	-	-	148 -
Stage 1	-	-	-	-	426 -
Stage 2	-	-	-	-	532 -

Approach	EB	WB	SB
HCM Control Delay, s	1.4	0	39.6
HCM LOS			E

Minor Lane/Major Mvmt	EBL	EBT	WBT	WBR	SBLn1	SBLn2
Capacity (veh/h)	792	-	-	-	148	438
HCM Lane V/C Ratio	0.097	-	-	-	0.527	0.098
HCM Control Delay (s)	10	0	-	-	53.6	14.1
HCM Lane LOS	B	A	-	-	F	B
HCM 95th %tile Q(veh)	0.3	-	-	-	2.6	0.3

HCM 6th Signalized Intersection Summary

UWMC - NW

15: N 115th St & Central Site Access (Future) Future With-Project (2040) AM Peak Hour_Access Parking (west weighted)

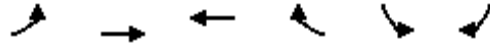

Movement	EBL	EBT	WBT	WBR	SBL	SBR
Lane Configurations	↙	↑	↔		↘	↗
Traffic Volume (veh/h)	129	406	364	250	148	63
Future Volume (veh/h)	129	406	364	250	148	63
Initial Q (Qb), veh	0	0	0	0	0	0
Ped-Bike Adj(A_pbT)	1.00			0.97	1.00	1.00
Parking Bus, Adj	1.00	1.00	1.00	1.00	1.00	1.00
Work Zone On Approach		No	No		No	
Adj Sat Flow, veh/h/ln	1826	1826	1767	1767	1900	1900
Adj Flow Rate, veh/h	129	406	364	250	148	63
Peak Hour Factor	1.00	1.00	1.00	1.00	1.00	1.00
Percent Heavy Veh, %	5	5	9	9	0	0
Cap, veh/h	479	1046	551	379	245	218
Arrive On Green	0.57	0.57	0.57	0.57	0.14	0.14
Sat Flow, veh/h	786	1826	962	661	1810	1610
Grp Volume(v), veh/h	129	406	0	614	148	63
Grp Sat Flow(s),veh/h/ln	786	1826	0	1622	1810	1610
Q Serve(g_s), s	4.2	3.8	0.0	8.0	2.4	1.1
Cycle Q Clear(g_c), s	12.2	3.8	0.0	8.0	2.4	1.1
Prop In Lane	1.00			0.41	1.00	1.00
Lane Grp Cap(c), veh/h	479	1046	0	930	245	218
V/C Ratio(X)	0.27	0.39	0.00	0.66	0.60	0.29
Avail Cap(c_a), veh/h	958	2159	0	1918	1436	1278
HCM Platoon Ratio	1.00	1.00	1.00	1.00	1.00	1.00
Upstream Filter(I)	1.00	1.00	0.00	1.00	1.00	1.00
Uniform Delay (d), s/veh	8.7	3.6	0.0	4.5	12.6	12.0
Incr Delay (d2), s/veh	0.3	0.2	0.0	0.8	2.4	0.7
Initial Q Delay(d3),s/veh	0.0	0.0	0.0	0.0	0.0	0.0
%ile BackOfQ(50%),veh/ln	0.5	0.5	0.0	1.0	0.9	0.3
Unsig. Movement Delay, s/veh						
LnGrp Delay(d),s/veh	9.0	3.9	0.0	5.3	15.0	12.7
LnGrp LOS	A	A	A	A	B	B
Approach Vol, veh/h		535	614		211	
Approach Delay, s/veh		5.1	5.3		14.3	
Approach LOS		A	A		B	
Timer - Assigned Phs				4	6	8
Phs Duration (G+Y+Rc), s				22.2	8.7	22.2
Change Period (Y+Rc), s				4.5	4.5	4.5
Max Green Setting (Gmax), s				36.5	24.5	36.5
Max Q Clear Time (g_c+I1), s				14.2	4.4	10.0
Green Ext Time (p_c), s				3.5	0.6	4.9
Intersection Summary						
HCM 6th Ctrl Delay			6.6			
HCM 6th LOS			A			

Intersection												
Int Delay, s/veh	2.1											
Movement	EBL	EBT	EBR	WBL	WBT	WBR	NBL	NBT	NBR	SBL	SBT	SBR
Lane Configurations		↕			↕			↕			↕	
Traffic Vol, veh/h	5	5	55	11	5	10	70	444	37	5	167	5
Future Vol, veh/h	5	5	55	11	5	10	70	444	37	5	167	5
Conflicting Peds, #/hr	0	0	7	7	0	0	0	0	8	8	0	0
Sign Control	Stop	Stop	Stop	Stop	Stop	Stop	Free	Free	Free	Free	Free	Free
RT Channelized	-	-	None	-	-	None	-	-	None	-	-	None
Storage Length	-	-	-	-	-	-	-	-	-	-	-	-
Veh in Median Storage, #	-	0	-	-	0	-	-	0	-	-	0	-
Grade, %	-	0	-	-	0	-	-	0	-	-	0	-
Peak Hour Factor	100	100	100	100	100	100	100	100	100	100	100	100
Heavy Vehicles, %	9	9	9	5	5	5	2	2	2	6	6	6
Mvmt Flow	5	5	55	11	5	10	70	444	37	5	167	5

Major/Minor	Minor2		Minor1		Major1			Major2				
Conflicting Flow All	790	809	177	828	793	471	172	0	0	489	0	0
Stage 1	180	180	-	611	611	-	-	-	-	-	-	-
Stage 2	610	629	-	217	182	-	-	-	-	-	-	-
Critical Hdwy	7.19	6.59	6.29	7.15	6.55	6.25	4.12	-	-	4.16	-	-
Critical Hdwy Stg 1	6.19	5.59	-	6.15	5.55	-	-	-	-	-	-	-
Critical Hdwy Stg 2	6.19	5.59	-	6.15	5.55	-	-	-	-	-	-	-
Follow-up Hdwy	3.581	4.081	3.381	3.545	4.045	3.345	2.218	-	-	2.254	-	-
Pot Cap-1 Maneuver	300	306	848	287	318	587	1405	-	-	1054	-	-
Stage 1	806	737	-	476	480	-	-	-	-	-	-	-
Stage 2	470	465	-	779	743	-	-	-	-	-	-	-
Platoon blocked, %								-	-	-	-	-
Mov Cap-1 Maneuver	275	282	842	247	293	583	1405	-	-	1046	-	-
Mov Cap-2 Maneuver	275	282	-	247	293	-	-	-	-	-	-	-
Stage 1	751	733	-	440	444	-	-	-	-	-	-	-
Stage 2	426	430	-	715	739	-	-	-	-	-	-	-

Approach	EB		WB		NB			SB		
HCM Control Delay, s	11.2		16.8		1			0.2		
HCM LOS	B		C							

Minor Lane/Major Mvmt	NBL	NBT	NBR	EBLn1WBLn1	SBL	SBT	SBR
Capacity (veh/h)	1405	-	-	642	330	1046	-
HCM Lane V/C Ratio	0.05	-	-	0.101	0.079	0.005	-
HCM Control Delay (s)	7.7	0	-	11.2	16.8	8.5	0
HCM Lane LOS	A	A	-	B	C	A	A
HCM 95th %tile Q(veh)	0.2	-	-	0.3	0.3	0	-

Intersection						
Int Delay, s/veh	6					
Movement	EBL	EBT	WBT	WBR	SBL	SBR
Lane Configurations		↕	↕		↕	↕
Traffic Vol, veh/h	20	303	516	39	168	77
Future Vol, veh/h	20	303	516	39	168	77
Conflicting Peds, #/hr	23	0	0	23	0	0
Sign Control	Free	Free	Free	Free	Stop	Stop
RT Channelized	-	None	-	None	-	None
Storage Length	-	-	-	-	0	0
Veh in Median Storage, #	-	0	0	-	0	-
Grade, %	-	0	0	-	0	-
Peak Hour Factor	100	100	100	100	100	100
Heavy Vehicles, %	2	2	6	6	0	0
Mvmt Flow	20	303	516	39	168	77
Major/Minor	Major1	Major2	Minor2			
Conflicting Flow All	578	0	-	0	902	559
Stage 1	-	-	-	-	559	-
Stage 2	-	-	-	-	343	-
Critical Hdwy	4.12	-	-	-	6.4	6.2
Critical Hdwy Stg 1	-	-	-	-	5.4	-
Critical Hdwy Stg 2	-	-	-	-	5.4	-
Follow-up Hdwy	2.218	-	-	-	3.5	3.3
Pot Cap-1 Maneuver	996	-	-	-	311	532
Stage 1	-	-	-	-	576	-
Stage 2	-	-	-	-	723	-
Platoon blocked, %		-	-	-		
Mov Cap-1 Maneuver	974	-	-	-	290	520
Mov Cap-2 Maneuver	-	-	-	-	290	-
Stage 1	-	-	-	-	550	-
Stage 2	-	-	-	-	707	-
Approach	EB	WB	SB			
HCM Control Delay, s	0.5	0	26.9			
HCM LOS			D			
Minor Lane/Major Mvmt	EBL	EBT	WBT	WBR	SBLn1	SBLn2
Capacity (veh/h)	974	-	-	-	290	520
HCM Lane V/C Ratio	0.021	-	-	-	0.579	0.148
HCM Control Delay (s)	8.8	0	-	-	33.2	13.1
HCM Lane LOS	A	A	-	-	D	B
HCM 95th %tile Q(veh)	0.1	-	-	-	3.4	0.5

Intersection						
Int Delay, s/veh	7.8					
Movement	EBL	EBT	WBT	WBR	SBL	SBR
Lane Configurations		↕	↔		↕	↕
Traffic Vol, veh/h	17	729	405	46	145	82
Future Vol, veh/h	17	729	405	46	145	82
Conflicting Peds, #/hr	23	0	0	23	0	0
Sign Control	Free	Free	Free	Free	Stop	Stop
RT Channelized	-	None	-	None	-	None
Storage Length	-	-	-	-	0	0
Veh in Median Storage, #	-	0	0	-	0	-
Grade, %	-	0	0	-	0	-
Peak Hour Factor	100	100	100	100	100	100
Heavy Vehicles, %	2	2	6	6	0	0
Mvmt Flow	17	729	405	46	145	82

Major/Minor	Major1	Major2	Minor2		
Conflicting Flow All	474	0	-	0	1214 451
Stage 1	-	-	-	-	451 -
Stage 2	-	-	-	-	763 -
Critical Hdwy	4.12	-	-	-	6.4 6.2
Critical Hdwy Stg 1	-	-	-	-	5.4 -
Critical Hdwy Stg 2	-	-	-	-	5.4 -
Follow-up Hdwy	2.218	-	-	-	3.5 3.3
Pot Cap-1 Maneuver	1088	-	-	-	202 613
Stage 1	-	-	-	-	646 -
Stage 2	-	-	-	-	464 -
Platoon blocked, %		-	-	-	
Mov Cap-1 Maneuver	1064	-	-	-	188 600
Mov Cap-2 Maneuver	-	-	-	-	188 -
Stage 1	-	-	-	-	615 -
Stage 2	-	-	-	-	454 -

Approach	EB	WB	SB
HCM Control Delay, s	0.2	0	48.4
HCM LOS			E

Minor Lane/Major Mvmt	EBL	EBT	WBT	WBR	SBLn1	SBLn2
Capacity (veh/h)	1064	-	-	-	188	600
HCM Lane V/C Ratio	0.016	-	-	-	0.771	0.137
HCM Control Delay (s)	8.4	0	-	-	69.1	11.9
HCM Lane LOS	A	A	-	-	F	B
HCM 95th %tile Q(veh)	0	-	-	-	5.2	0.5

HCM 6th Signalized Intersection Summary

UWMC - NW

15: N 115th St & Central Site Access (Future) Future With-Project (2040) PM Peak Hour_Access Parking (west weighted)



Movement	EBL	EBT	WBT	WBR	SBL	SBR
Lane Configurations						
Traffic Volume (veh/h)	31	459	435	57	286	124
Future Volume (veh/h)	31	459	435	57	286	124
Initial Q (Qb), veh	0	0	0	0	0	0
Ped-Bike Adj(A_pbT)	0.99			0.98	1.00	1.00
Parking Bus, Adj	1.00	1.00	1.00	1.00	1.00	1.00
Work Zone On Approach		No	No		No	
Adj Sat Flow, veh/h/ln	1870	1870	1811	1811	1900	1900
Adj Flow Rate, veh/h	31	459	435	57	286	124
Peak Hour Factor	1.00	1.00	1.00	1.00	1.00	1.00
Percent Heavy Veh, %	2	2	6	6	0	0
Cap, veh/h	456	829	694	91	441	392
Arrive On Green	0.44	0.44	0.44	0.44	0.24	0.24
Sat Flow, veh/h	899	1870	1565	205	1810	1610
Grp Volume(v), veh/h	31	459	0	492	286	124
Grp Sat Flow(s),veh/h/ln	899	1870	0	1770	1810	1610
Q Serve(g_s), s	0.8	5.2	0.0	6.2	4.1	1.8
Cycle Q Clear(g_c), s	7.0	5.2	0.0	6.2	4.1	1.8
Prop In Lane	1.00			0.12	1.00	1.00
Lane Grp Cap(c), veh/h	456	829	0	785	441	392
V/C Ratio(X)	0.07	0.55	0.00	0.63	0.65	0.32
Avail Cap(c_a), veh/h	1199	2373	0	2246	1541	1371
HCM Platoon Ratio	1.00	1.00	1.00	1.00	1.00	1.00
Upstream Filter(I)	1.00	1.00	0.00	1.00	1.00	1.00
Uniform Delay (d), s/veh	8.8	5.9	0.0	6.2	9.8	8.9
Incr Delay (d2), s/veh	0.1	0.6	0.0	0.8	1.6	0.5
Initial Q Delay(d3),s/veh	0.0	0.0	0.0	0.0	0.0	0.0
%ile BackOfQ(50%),veh/ln	0.1	1.1	0.0	1.2	1.3	0.5
Unsig. Movement Delay, s/veh						
LnGrp Delay(d),s/veh	8.9	6.5	0.0	7.0	11.4	9.4
LnGrp LOS	A	A	A	A	B	A
Approach Vol, veh/h		490	492		410	
Approach Delay, s/veh		6.6	7.0		10.8	
Approach LOS		A	A		B	
Timer - Assigned Phs				4	6	8
Phs Duration (G+Y+Rc), s				17.3	11.5	17.3
Change Period (Y+Rc), s				4.5	4.5	4.5
Max Green Setting (Gmax), s				36.5	24.5	36.5
Max Q Clear Time (g_c+I1), s				9.0	6.1	8.2
Green Ext Time (p_c), s				3.3	1.2	3.5
Intersection Summary						
HCM 6th Ctrl Delay			8.0			
HCM 6th LOS			A			

Intersection												
Int Delay, s/veh	4.1											
Movement	EBL	EBT	EBR	WBL	WBT	WBR	NBL	NBT	NBR	SBL	SBT	SBR
Lane Configurations		↕			↕			↕			↕	
Traffic Vol, veh/h	21	9	81	18	14	5	58	141	11	5	337	37
Future Vol, veh/h	21	9	81	18	14	5	58	141	11	5	337	37
Conflicting Peds, #/hr	1	0	4	4	0	1	1	0	12	12	0	1
Sign Control	Stop	Stop	Stop	Stop	Stop	Stop	Free	Free	Free	Free	Free	Free
RT Channelized	-	-	None	-	-	None	-	-	None	-	-	None
Storage Length	-	-	-	-	-	-	-	-	-	-	-	-
Veh in Median Storage, #	-	0	-	-	0	-	-	0	-	-	0	-
Grade, %	-	0	-	-	0	-	-	0	-	-	0	-
Peak Hour Factor	86	86	86	86	86	86	86	86	86	86	86	86
Heavy Vehicles, %	13	13	13	0	0	0	10	10	10	4	4	4
Mvmt Flow	24	10	94	21	16	6	67	164	13	6	392	43

Major/Minor	Minor2		Minor1		Major1		Major2					
Conflicting Flow All	744	750	419	799	765	184	436	0	0	189	0	0
Stage 1	427	427	-	317	317	-	-	-	-	-	-	-
Stage 2	317	323	-	482	448	-	-	-	-	-	-	-
Critical Hdwy	7.23	6.63	6.33	7.1	6.5	6.2	4.2	-	-	4.14	-	-
Critical Hdwy Stg 1	6.23	5.63	-	6.1	5.5	-	-	-	-	-	-	-
Critical Hdwy Stg 2	6.23	5.63	-	6.1	5.5	-	-	-	-	-	-	-
Follow-up Hdwy	3.617	4.117	3.417	3.5	4	3.3	2.29	-	-	2.236	-	-
Pot Cap-1 Maneuver	317	327	611	306	336	864	1082	-	-	1373	-	-
Stage 1	585	567	-	698	658	-	-	-	-	-	-	-
Stage 2	671	631	-	569	576	-	-	-	-	-	-	-
Platoon blocked, %								-	-	-	-	-
Mov Cap-1 Maneuver	284	299	608	234	307	853	1081	-	-	1357	-	-
Mov Cap-2 Maneuver	284	299	-	234	307	-	-	-	-	-	-	-
Stage 1	544	563	-	642	606	-	-	-	-	-	-	-
Stage 2	603	581	-	467	572	-	-	-	-	-	-	-

Approach	EB		WB		NB		SB	
HCM Control Delay, s	15.6		19.7		2.4		0.1	
HCM LOS	C		C					

Minor Lane/Major Mvmt	NBL	NBT	NBR	EBLn1WBLn1	SBL	SBT	SBR
Capacity (veh/h)	1081	-	-	468	288	1357	-
HCM Lane V/C Ratio	0.062	-	-	0.276	0.149	0.004	-
HCM Control Delay (s)	8.6	0	-	15.6	19.7	7.7	0
HCM Lane LOS	A	A	-	C	C	A	A
HCM 95th %tile Q(veh)	0.2	-	-	1.1	0.5	0	-

Intersection						
Int Delay, s/veh	5.5					
Movement	EBL	EBT	WBT	WBR	SBL	SBR
Lane Configurations		↕	↕		↕	↕
Traffic Vol, veh/h	118	349	196	206	107	66
Future Vol, veh/h	118	349	196	206	107	66
Conflicting Peds, #/hr	18	0	0	18	0	0
Sign Control	Free	Free	Free	Free	Stop	Stop
RT Channelized	-	None	-	None	-	None
Storage Length	-	-	-	-	0	0
Veh in Median Storage, #	-	0	0	-	0	-
Grade, %	-	0	0	-	0	-
Peak Hour Factor	91	91	91	91	91	91
Heavy Vehicles, %	5	5	9	9	0	0
Mvmt Flow	130	384	215	226	118	73

Major/Minor	Major1	Major2	Minor2		
Conflicting Flow All	459	0	-	0	990
Stage 1	-	-	-	-	346
Stage 2	-	-	-	-	644
Critical Hdwy	4.15	-	-	-	6.4
Critical Hdwy Stg 1	-	-	-	-	5.4
Critical Hdwy Stg 2	-	-	-	-	5.4
Follow-up Hdwy	2.245	-	-	-	3.5
Pot Cap-1 Maneuver	1086	-	-	-	276
Stage 1	-	-	-	-	721
Stage 2	-	-	-	-	527
Platoon blocked, %		-	-	-	
Mov Cap-1 Maneuver	1067	-	-	-	225
Mov Cap-2 Maneuver	-	-	-	-	225
Stage 1	-	-	-	-	599
Stage 2	-	-	-	-	518

Approach	EB	WB	SB
HCM Control Delay, s	2.2	0	27.2
HCM LOS			D

Minor Lane/Major Mvmt	EBL	EBT	WBT	WBR	SBLn1	SBLn2
Capacity (veh/h)	1067	-	-	-	225	690
HCM Lane V/C Ratio	0.122	-	-	-	0.523	0.105
HCM Control Delay (s)	8.8	0	-	-	37.3	10.8
HCM Lane LOS	A	A	-	-	E	B
HCM 95th %tile Q(veh)	0.4	-	-	-	2.7	0.4

Intersection

Int Delay, s/veh 34

Movement	EBL	EBT	WBT	WBR	SBL	SBR
Lane Configurations		↕	↕		↕	↕
Traffic Vol, veh/h	139	312	336	368	178	66
Future Vol, veh/h	139	312	336	368	178	66
Conflicting Peds, #/hr	18	0	0	18	0	0
Sign Control	Free	Free	Free	Free	Stop	Stop
RT Channelized	-	None	-	None	-	None
Storage Length	-	-	-	-	0	0
Veh in Median Storage, #	-	0	0	-	0	-
Grade, %	-	0	0	-	0	-
Peak Hour Factor	91	91	91	91	91	91
Heavy Vehicles, %	5	5	9	9	0	0
Mvmt Flow	153	343	369	404	196	73

Major/Minor	Major1	Major2	Minor2
Conflicting Flow All	791	0	0
Stage 1	-	-	-
Stage 2	-	-	-
Critical Hdwy	4.15	-	-
Critical Hdwy Stg 1	-	-	-
Critical Hdwy Stg 2	-	-	-
Follow-up Hdwy	2.245	-	-
Pot Cap-1 Maneuver	816	-	-
Stage 1	-	-	-
Stage 2	-	-	-
Platoon blocked, %	-	-	-
Mov Cap-1 Maneuver	802	-	-
Mov Cap-2 Maneuver	-	-	-
Stage 1	-	-	-
Stage 2	-	-	-

Approach	EB	WB	SB
HCM Control Delay, s	3.2	0	189
HCM LOS			F

Minor Lane/Major Mvmt	EBL	EBT	WBT	WBR	SBLn1	SBLn2
Capacity (veh/h)	802	-	-	-	145	503
HCM Lane V/C Ratio	0.19	-	-	-	1.349	0.144
HCM Control Delay (s)	10.5	0	-	-	254.1	13.4
HCM Lane LOS	B	A	-	-	F	B
HCM 95th %tile Q(veh)	0.7	-	-	-	12.3	0.5

Notes

~: Volume exceeds capacity \$: Delay exceeds 300s +: Computation Not Defined *: All major volume in platoon

Intersection						
Int Delay, s/veh	3.5					
Movement	EBT	EBR	WBL	WBT	NBL	NBR
Lane Configurations						
Traffic Vol, veh/h	75	0	64	45	0	31
Future Vol, veh/h	75	0	64	45	0	31
Conflicting Peds, #/hr	0	0	0	0	0	0
Sign Control	Free	Free	Free	Free	Stop	Stop
RT Channelized	-	None	-	None	-	None
Storage Length	-	-	-	-	0	-
Veh in Median Storage, #	0	-	-	0	0	-
Grade, %	0	-	-	0	0	-
Peak Hour Factor	91	91	91	91	91	91
Heavy Vehicles, %	13	13	0	0	0	0
Mvmt Flow	82	0	70	49	0	34
Major/Minor	Major1	Major2	Minor1			
Conflicting Flow All	0	0	82	0	271	82
Stage 1	-	-	-	-	82	-
Stage 2	-	-	-	-	189	-
Critical Hdwy	-	-	4.1	-	6.4	6.2
Critical Hdwy Stg 1	-	-	-	-	5.4	-
Critical Hdwy Stg 2	-	-	-	-	5.4	-
Follow-up Hdwy	-	-	2.2	-	3.5	3.3
Pot Cap-1 Maneuver	-	-	1528	-	723	983
Stage 1	-	-	-	-	946	-
Stage 2	-	-	-	-	848	-
Platoon blocked, %	-	-	-	-	-	-
Mov Cap-1 Maneuver	-	-	1528	-	689	983
Mov Cap-2 Maneuver	-	-	-	-	689	-
Stage 1	-	-	-	-	946	-
Stage 2	-	-	-	-	808	-
Approach	EB	WB	NB			
HCM Control Delay, s	0	4.4	8.8			
HCM LOS				A		
Minor Lane/Major Mvmt	NBLn1	EBT	EBR	WBL	WBT	
Capacity (veh/h)	983	-	-	1528	-	
HCM Lane V/C Ratio	0.035	-	-	0.046	-	
HCM Control Delay (s)	8.8	-	-	7.5	0	
HCM Lane LOS	A	-	-	A	A	
HCM 95th %tile Q(veh)	0.1	-	-	0.1	-	

Intersection												
Int Delay, s/veh	4											
Movement	EBL	EBT	EBR	WBL	WBT	WBR	NBL	NBT	NBR	SBL	SBT	SBR
Lane Configurations		↕			↕			↕			↕	
Traffic Vol, veh/h	37	14	73	9	7	10	77	397	23	5	149	14
Future Vol, veh/h	37	14	73	9	7	10	77	397	23	5	149	14
Conflicting Peds, #/hr	0	0	7	7	0	0	0	0	8	8	0	0
Sign Control	Stop	Stop	Stop	Stop	Stop	Stop	Free	Free	Free	Free	Free	Free
RT Channelized	-	-	None	-	-	None	-	-	None	-	-	None
Storage Length	-	-	-	-	-	-	-	-	-	-	-	-
Veh in Median Storage, #	-	0	-	-	0	-	-	0	-	-	0	-
Grade, %	-	0	-	-	0	-	-	0	-	-	0	-
Peak Hour Factor	89	89	89	89	89	89	89	89	89	89	89	89
Heavy Vehicles, %	9	9	9	5	5	5	2	2	2	6	6	6
Mvmt Flow	42	16	82	10	8	11	87	446	26	6	167	16

Major/Minor	Minor2		Minor1		Major1			Major2				
Conflicting Flow All	830	841	182	884	836	467	183	0	0	480	0	0
Stage 1	187	187	-	641	641	-	-	-	-	-	-	-
Stage 2	643	654	-	243	195	-	-	-	-	-	-	-
Critical Hdwy	7.19	6.59	6.29	7.15	6.55	6.25	4.12	-	-	4.16	-	-
Critical Hdwy Stg 1	6.19	5.59	-	6.15	5.55	-	-	-	-	-	-	-
Critical Hdwy Stg 2	6.19	5.59	-	6.15	5.55	-	-	-	-	-	-	-
Follow-up Hdwy	3.581	4.081	3.381	3.545	4.045	3.345	2.218	-	-	2.254	-	-
Pot Cap-1 Maneuver	281	294	843	263	300	590	1392	-	-	1062	-	-
Stage 1	799	732	-	458	465	-	-	-	-	-	-	-
Stage 2	450	452	-	754	734	-	-	-	-	-	-	-
Platoon blocked, %								-	-	-	-	-
Mov Cap-1 Maneuver	251	265	837	208	271	586	1392	-	-	1054	-	-
Mov Cap-2 Maneuver	251	265	-	208	271	-	-	-	-	-	-	-
Stage 1	731	728	-	416	422	-	-	-	-	-	-	-
Stage 2	396	410	-	657	730	-	-	-	-	-	-	-

Approach	EB		WB		NB		SB	
HCM Control Delay, s	17.3		18.2		1.2		0.3	
HCM LOS	C		C					

Minor Lane/Major Mvmt	NBL	NBT	NBR	EBLn1WBLn1	SBL	SBT	SBR
Capacity (veh/h)	1392	-	-	431	302	1054	-
HCM Lane V/C Ratio	0.062	-	-	0.323	0.097	0.005	-
HCM Control Delay (s)	7.8	0	-	17.3	18.2	8.4	0
HCM Lane LOS	A	A	-	C	C	A	A
HCM 95th %tile Q(veh)	0.2	-	-	1.4	0.3	0	-

Intersection

Int Delay, s/veh 5.5

Movement	EBL	EBT	WBT	WBR	SBL	SBR
Lane Configurations		↕	↕		↕	↕
Traffic Vol, veh/h	20	276	440	38	142	96
Future Vol, veh/h	20	276	440	38	142	96
Conflicting Peds, #/hr	23	0	0	23	0	0
Sign Control	Free	Free	Free	Free	Stop	Stop
RT Channelized	-	None	-	None	-	None
Storage Length	-	-	-	-	0	0
Veh in Median Storage, #	-	0	0	-	0	-
Grade, %	-	0	0	-	0	-
Peak Hour Factor	91	91	91	91	91	91
Heavy Vehicles, %	2	2	6	6	0	0
Mvmt Flow	22	303	484	42	156	105

Major/Minor	Major1	Major2	Minor2
Conflicting Flow All	549	0	0
Stage 1	-	-	-
Stage 2	-	-	-
Critical Hdwy	4.12	-	-
Critical Hdwy Stg 1	-	-	-
Critical Hdwy Stg 2	-	-	-
Follow-up Hdwy	2.218	-	-
Pot Cap-1 Maneuver	1021	-	-
Stage 1	-	-	-
Stage 2	-	-	-
Platoon blocked, %	-	-	-
Mov Cap-1 Maneuver	999	-	-
Mov Cap-2 Maneuver	-	-	-
Stage 1	-	-	-
Stage 2	-	-	-

Approach	EB	WB	SB
HCM Control Delay, s	0.6	0	22.8
HCM LOS			C

Minor Lane/Major Mvmt	EBL	EBT	WBT	WBR	SBLn1	SBLn2
Capacity (veh/h)	999	-	-	-	300	542
HCM Lane V/C Ratio	0.022	-	-	-	0.52	0.195
HCM Control Delay (s)	8.7	0	-	-	29.3	13.2
HCM Lane LOS	A	A	-	-	D	B
HCM 95th %tile Q(veh)	0.1	-	-	-	2.8	0.7

Intersection

Int Delay, s/veh 51.3

Movement	EBL	EBT	WBT	WBR	SBL	SBR
Lane Configurations		↕	↕		↕	↕
Traffic Vol, veh/h	29	492	342	69	291	98
Future Vol, veh/h	29	492	342	69	291	98
Conflicting Peds, #/hr	23	0	0	23	0	0
Sign Control	Free	Free	Free	Free	Stop	Stop
RT Channelized	-	None	-	None	-	None
Storage Length	-	-	-	-	0	0
Veh in Median Storage, #	-	0	0	-	0	-
Grade, %	-	0	0	-	0	-
Peak Hour Factor	91	91	91	91	91	91
Heavy Vehicles, %	2	2	6	6	0	0
Mvmt Flow	32	541	376	76	320	108

Major/Minor

	Major1	Major2	Minor2
Conflicting Flow All	475	0	0 1042 437
Stage 1	-	-	- 437 -
Stage 2	-	-	- 605 -
Critical Hdwy	4.12	-	- 6.4 6.2
Critical Hdwy Stg 1	-	-	- 5.4 -
Critical Hdwy Stg 2	-	-	- 5.4 -
Follow-up Hdwy	2.218	-	- 3.5 3.3
Pot Cap-1 Maneuver	1087	-	- ~ 257 624
Stage 1	-	-	- 655 -
Stage 2	-	-	- 549 -
Platoon blocked, %		-	-
Mov Cap-1 Maneuver	1063	-	- ~ 235 610
Mov Cap-2 Maneuver	-	-	- ~ 235 -
Stage 1	-	-	- 613 -
Stage 2	-	-	- 537 -

Approach

	EB	WB	SB
HCM Control Delay, s	0.5	0	173.6
HCM LOS			F

Minor Lane/Major Mvmt

	EBL	EBT	WBT	WBR	SBLn1	SBLn2
Capacity (veh/h)	1063	-	-	-	235	610
HCM Lane V/C Ratio	0.03	-	-	-	1.361	0.177
HCM Control Delay (s)	8.5	0	-	-	227.9	12.2
HCM Lane LOS	A	A	-	-	F	B
HCM 95th %tile Q(veh)	0.1	-	-	-	17.5	0.6

Notes

~: Volume exceeds capacity \$: Delay exceeds 300s +: Computation Not Defined *: All major volume in platoon

Intersection						
Int Delay, s/veh	3.3					
Movement	EBT	EBR	WBL	WBT	NBL	NBR
Lane Configurations						
Traffic Vol, veh/h	55	0	17	75	0	64
Future Vol, veh/h	55	0	17	75	0	64
Conflicting Peds, #/hr	0	0	0	0	0	0
Sign Control	Free	Free	Free	Free	Stop	Stop
RT Channelized	-	None	-	None	-	None
Storage Length	-	-	-	-	0	-
Veh in Median Storage, #	0	-	-	0	0	-
Grade, %	0	-	-	0	0	-
Peak Hour Factor	91	91	91	91	91	91
Heavy Vehicles, %	9	9	5	5	0	0
Mvmt Flow	60	0	19	82	0	70
Major/Minor	Major1	Major2	Minor1			
Conflicting Flow All	0	0	60	0	180	60
Stage 1	-	-	-	-	60	-
Stage 2	-	-	-	-	120	-
Critical Hdwy	-	-	4.15	-	6.4	6.2
Critical Hdwy Stg 1	-	-	-	-	5.4	-
Critical Hdwy Stg 2	-	-	-	-	5.4	-
Follow-up Hdwy	-	-	2.245	-	3.5	3.3
Pot Cap-1 Maneuver	-	-	1525	-	814	1011
Stage 1	-	-	-	-	968	-
Stage 2	-	-	-	-	910	-
Platoon blocked, %	-	-	-	-	-	-
Mov Cap-1 Maneuver	-	-	1525	-	803	1011
Mov Cap-2 Maneuver	-	-	-	-	803	-
Stage 1	-	-	-	-	968	-
Stage 2	-	-	-	-	898	-
Approach	EB	WB	NB			
HCM Control Delay, s	0	1.4	8.8			
HCM LOS			A			
Minor Lane/Major Mvmt	NBLn1	EBT	EBR	WBL	WBT	
Capacity (veh/h)	1011	-	-	1525	-	
HCM Lane V/C Ratio	0.07	-	-	0.012	-	
HCM Control Delay (s)	8.8	-	-	7.4	0	
HCM Lane LOS	A	-	-	A	A	
HCM 95th %tile Q(veh)	0.2	-	-	0	-	

Intersection												
Int Delay, s/veh	3.7											
Movement	EBL	EBT	EBR	WBL	WBT	WBR	NBL	NBT	NBR	SBL	SBT	SBR
Lane Configurations		↕			↕			↕			↕	
Traffic Vol, veh/h	21	9	88	18	14	5	65	156	12	5	368	38
Future Vol, veh/h	21	9	88	18	14	5	65	156	12	5	368	38
Conflicting Peds, #/hr	1	0	4	4	0	1	1	0	12	12	0	1
Sign Control	Stop	Stop	Stop	Stop	Stop	Stop	Free	Free	Free	Free	Free	Free
RT Channelized	-	-	None	-	-	None	-	-	None	-	-	None
Storage Length	-	-	-	-	-	-	-	-	-	-	-	-
Veh in Median Storage, #	-	0	-	-	0	-	-	0	-	-	0	-
Grade, %	-	0	-	-	0	-	-	0	-	-	0	-
Peak Hour Factor	100	100	100	100	100	100	100	100	100	100	100	100
Heavy Vehicles, %	13	13	13	0	0	0	10	10	10	4	4	4
Mvmt Flow	21	9	88	18	14	5	65	156	12	5	368	38

Major/Minor	Minor2		Minor1		Major1			Major2				
Conflicting Flow All	701	708	392	754	721	175	407	0	0	180	0	0
Stage 1	398	398	-	304	304	-	-	-	-	-	-	-
Stage 2	303	310	-	450	417	-	-	-	-	-	-	-
Critical Hdwy	7.23	6.63	6.33	7.1	6.5	6.2	4.2	-	-	4.14	-	-
Critical Hdwy Stg 1	6.23	5.63	-	6.1	5.5	-	-	-	-	-	-	-
Critical Hdwy Stg 2	6.23	5.63	-	6.1	5.5	-	-	-	-	-	-	-
Follow-up Hdwy	3.617	4.117	3.417	3.5	4	3.3	2.29	-	-	2.236	-	-
Pot Cap-1 Maneuver	339	346	633	328	356	874	1110	-	-	1384	-	-
Stage 1	606	584	-	710	667	-	-	-	-	-	-	-
Stage 2	683	640	-	592	595	-	-	-	-	-	-	-
Platoon blocked, %								-	-	-	-	-
Mov Cap-1 Maneuver	308	318	630	257	327	863	1109	-	-	1368	-	-
Mov Cap-2 Maneuver	308	318	-	257	327	-	-	-	-	-	-	-
Stage 1	566	580	-	656	617	-	-	-	-	-	-	-
Stage 2	620	592	-	497	591	-	-	-	-	-	-	-

Approach	EB		WB		NB		SB	
HCM Control Delay, s	14.4		18.1		2.4		0.1	
HCM LOS	B		C					

Minor Lane/Major Mvmt	NBL	NBT	NBR	EBLn1WBLn1	SBL	SBT	SBR
Capacity (veh/h)	1109	-	-	500	312	1368	-
HCM Lane V/C Ratio	0.059	-	-	0.236	0.119	0.004	-
HCM Control Delay (s)	8.4	0	-	14.4	18.1	7.6	0
HCM Lane LOS	A	A	-	B	C	A	A
HCM 95th %tile Q(veh)	0.2	-	-	0.9	0.4	0	-

Intersection						
Int Delay, s/veh	4.7					
Movement	EBL	EBT	WBT	WBR	SBL	SBR
Lane Configurations		↶	↷		↶	↷
Traffic Vol, veh/h	120	377	212	210	108	68
Future Vol, veh/h	120	377	212	210	108	68
Conflicting Peds, #/hr	18	0	0	18	0	0
Sign Control	Free	Free	Free	Free	Stop	Stop
RT Channelized	-	None	-	None	-	None
Storage Length	-	-	-	-	0	0
Veh in Median Storage, #	-	0	0	-	0	-
Grade, %	-	0	0	-	0	-
Peak Hour Factor	100	100	100	100	100	100
Heavy Vehicles, %	5	5	9	9	0	0
Mvmt Flow	120	377	212	210	108	68

Major/Minor	Major1	Major2	Minor2		
Conflicting Flow All	440	0	-	0	952 335
Stage 1	-	-	-	-	335 -
Stage 2	-	-	-	-	617 -
Critical Hdwy	4.15	-	-	-	6.4 6.2
Critical Hdwy Stg 1	-	-	-	-	5.4 -
Critical Hdwy Stg 2	-	-	-	-	5.4 -
Follow-up Hdwy	2.245	-	-	-	3.5 3.3
Pot Cap-1 Maneuver	1104	-	-	-	290 712
Stage 1	-	-	-	-	729 -
Stage 2	-	-	-	-	542 -
Platoon blocked, %		-	-	-	
Mov Cap-1 Maneuver	1085	-	-	-	241 700
Mov Cap-2 Maneuver	-	-	-	-	241 -
Stage 1	-	-	-	-	616 -
Stage 2	-	-	-	-	533 -

Approach	EB	WB	SB
HCM Control Delay, s	2.1	0	23.5
HCM LOS			C

Minor Lane/Major Mvmt	EBL	EBT	WBT	WBR	SBLn1	SBLn2
Capacity (veh/h)	1085	-	-	-	241	700
HCM Lane V/C Ratio	0.111	-	-	-	0.448	0.097
HCM Control Delay (s)	8.7	0	-	-	31.5	10.7
HCM Lane LOS	A	A	-	-	D	B
HCM 95th %tile Q(veh)	0.4	-	-	-	2.2	0.3

Intersection

Int Delay, s/veh 22.7

Movement	EBL	EBT	WBT	WBR	SBL	SBR
Lane Configurations		↕	↕		↕	↕
Traffic Vol, veh/h	142	338	361	376	182	66
Future Vol, veh/h	142	338	361	376	182	66
Conflicting Peds, #/hr	18	0	0	18	0	0
Sign Control	Free	Free	Free	Free	Stop	Stop
RT Channelized	-	None	-	None	-	None
Storage Length	-	-	-	-	0	0
Veh in Median Storage, #	-	0	0	-	0	-
Grade, %	-	0	0	-	0	-
Peak Hour Factor	100	100	100	100	100	100
Heavy Vehicles, %	5	5	9	9	0	0
Mvmt Flow	142	338	361	376	182	66

Major/Minor	Major1	Major2	Minor2
Conflicting Flow All	755	0	0
Stage 1	-	-	-
Stage 2	-	-	-
Critical Hdwy	4.15	-	-
Critical Hdwy Stg 1	-	-	-
Critical Hdwy Stg 2	-	-	-
Follow-up Hdwy	2.245	-	-
Pot Cap-1 Maneuver	842	-	-
Stage 1	-	-	-
Stage 2	-	-	-
Platoon blocked, %	-	-	-
Mov Cap-1 Maneuver	828	-	-
Mov Cap-2 Maneuver	-	-	-
Stage 1	-	-	-
Stage 2	-	-	-

Approach	EB	WB	SB
HCM Control Delay, s	3	0	128.3
HCM LOS			F

Minor Lane/Major Mvmt	EBL	EBT	WBT	WBR	SBLn1	SBLn2
Capacity (veh/h)	828	-	-	-	160	518
HCM Lane V/C Ratio	0.171	-	-	-	1.138	0.127
HCM Control Delay (s)	10.2	0	-	-	170.1	13
HCM Lane LOS	B	A	-	-	F	B
HCM 95th %tile Q(veh)	0.6	-	-	-	9.8	0.4

Notes

~: Volume exceeds capacity \$: Delay exceeds 300s +: Computation Not Defined *: All major volume in platoon

Intersection						
Int Delay, s/veh	3.5					
Movement	EBT	EBR	WBL	WBT	NBL	NBR
Lane Configurations						
Traffic Vol, veh/h	80	0	67	50	0	33
Future Vol, veh/h	80	0	67	50	0	33
Conflicting Peds, #/hr	0	0	0	0	0	0
Sign Control	Free	Free	Free	Free	Stop	Stop
RT Channelized	-	None	-	None	-	None
Storage Length	-	-	-	-	0	-
Veh in Median Storage, #	0	-	-	0	0	-
Grade, %	0	-	-	0	0	-
Peak Hour Factor	100	100	100	100	100	100
Heavy Vehicles, %	13	13	0	0	0	0
Mvmt Flow	80	0	67	50	0	33
Major/Minor	Major1	Major2	Minor1			
Conflicting Flow All	0	0	80	0	264	80
Stage 1	-	-	-	-	80	-
Stage 2	-	-	-	-	184	-
Critical Hdwy	-	-	4.1	-	6.4	6.2
Critical Hdwy Stg 1	-	-	-	-	5.4	-
Critical Hdwy Stg 2	-	-	-	-	5.4	-
Follow-up Hdwy	-	-	2.2	-	3.5	3.3
Pot Cap-1 Maneuver	-	-	1531	-	729	986
Stage 1	-	-	-	-	948	-
Stage 2	-	-	-	-	852	-
Platoon blocked, %	-	-	-	-	-	-
Mov Cap-1 Maneuver	-	-	1531	-	696	986
Mov Cap-2 Maneuver	-	-	-	-	696	-
Stage 1	-	-	-	-	948	-
Stage 2	-	-	-	-	814	-
Approach	EB	WB	NB			
HCM Control Delay, s	0	4.3	8.8			
HCM LOS				A		
Minor Lane/Major Mvmt	NBLn1	EBT	EBR	WBL	WBT	
Capacity (veh/h)	986	-	-	1531	-	
HCM Lane V/C Ratio	0.033	-	-	0.044	-	
HCM Control Delay (s)	8.8	-	-	7.5	0	
HCM Lane LOS	A	-	-	A	A	
HCM 95th %tile Q(veh)	0.1	-	-	0.1	-	

Intersection												
Int Delay, s/veh	3.6											
Movement	EBL	EBT	EBR	WBL	WBT	WBR	NBL	NBT	NBR	SBL	SBT	SBR
Lane Configurations		↕			↕			↕			↕	
Traffic Vol, veh/h	38	14	79	9	7	10	78	433	28	5	159	14
Future Vol, veh/h	38	14	79	9	7	10	78	433	28	5	159	14
Conflicting Peds, #/hr	0	0	7	7	0	0	0	0	8	8	0	0
Sign Control	Stop	Stop	Stop	Stop	Stop	Stop	Free	Free	Free	Free	Free	Free
RT Channelized	-	-	None	-	-	None	-	-	None	-	-	None
Storage Length	-	-	-	-	-	-	-	-	-	-	-	-
Veh in Median Storage, #	-	0	-	-	0	-	-	0	-	-	0	-
Grade, %	-	0	-	-	0	-	-	0	-	-	0	-
Peak Hour Factor	100	100	100	100	100	100	100	100	100	100	100	100
Heavy Vehicles, %	9	9	9	5	5	5	2	2	2	6	6	6
Mvmt Flow	38	14	79	9	7	10	78	433	28	5	159	14

Major/Minor	Minor2		Minor1		Major1		Major2					
Conflicting Flow All	788	801	173	841	794	455	173	0	0	469	0	0
Stage 1	176	176	-	611	611	-	-	-	-	-	-	-
Stage 2	612	625	-	230	183	-	-	-	-	-	-	-
Critical Hdwy	7.19	6.59	6.29	7.15	6.55	6.25	4.12	-	-	4.16	-	-
Critical Hdwy Stg 1	6.19	5.59	-	6.15	5.55	-	-	-	-	-	-	-
Critical Hdwy Stg 2	6.19	5.59	-	6.15	5.55	-	-	-	-	-	-	-
Follow-up Hdwy	3.581	4.081	3.381	3.545	4.045	3.345	2.218	-	-	2.254	-	-
Pot Cap-1 Maneuver	301	310	853	281	317	599	1404	-	-	1072	-	-
Stage 1	810	740	-	476	480	-	-	-	-	-	-	-
Stage 2	469	467	-	766	743	-	-	-	-	-	-	-
Platoon blocked, %								-	-	-	-	-
Mov Cap-1 Maneuver	273	283	847	227	289	594	1404	-	-	1064	-	-
Mov Cap-2 Maneuver	273	283	-	227	289	-	-	-	-	-	-	-
Stage 1	749	736	-	437	441	-	-	-	-	-	-	-
Stage 2	420	429	-	673	739	-	-	-	-	-	-	-

Approach	EB		WB		NB		SB	
HCM Control Delay, s	15.8		17.2		1.1		0.2	
HCM LOS	C		C					

Minor Lane/Major Mvmt	NBL	NBT	NBR	EBLn1WBLn1	SBL	SBT	SBR
Capacity (veh/h)	1404	-	-	465	322	1064	-
HCM Lane V/C Ratio	0.056	-	-	0.282	0.081	0.005	-
HCM Control Delay (s)	7.7	0	-	15.8	17.2	8.4	0
HCM Lane LOS	A	A	-	C	C	A	A
HCM 95th %tile Q(veh)	0.2	-	-	1.1	0.3	0	-

Intersection						
Int Delay, s/veh	7.8					
Movement	EBL	EBT	WBT	WBR	SBL	SBR
Lane Configurations		↶	↷		↶	↷
Traffic Vol, veh/h	27	288	439	46	203	131
Future Vol, veh/h	27	288	439	46	203	131
Conflicting Peds, #/hr	23	0	0	23	0	0
Sign Control	Free	Free	Free	Free	Stop	Stop
RT Channelized	-	None	-	None	-	None
Storage Length	-	-	-	-	0	0
Veh in Median Storage, #	-	0	0	-	0	-
Grade, %	-	0	0	-	0	-
Peak Hour Factor	100	100	100	100	100	100
Heavy Vehicles, %	2	2	6	6	0	0
Mvmt Flow	27	288	439	46	203	131

Major/Minor	Major1	Major2	Minor2		
Conflicting Flow All	508	0	-	0	827 485
Stage 1	-	-	-	-	485 -
Stage 2	-	-	-	-	342 -
Critical Hdwy	4.12	-	-	-	6.4 6.2
Critical Hdwy Stg 1	-	-	-	-	5.4 -
Critical Hdwy Stg 2	-	-	-	-	5.4 -
Follow-up Hdwy	2.218	-	-	-	3.5 3.3
Pot Cap-1 Maneuver	1057	-	-	-	344 586
Stage 1	-	-	-	-	623 -
Stage 2	-	-	-	-	724 -
Platoon blocked, %		-	-	-	
Mov Cap-1 Maneuver	1034	-	-	-	319 573
Mov Cap-2 Maneuver	-	-	-	-	319 -
Stage 1	-	-	-	-	591 -
Stage 2	-	-	-	-	708 -

Approach	EB	WB	SB
HCM Control Delay, s	0.7	0	25.9
HCM LOS			D

Minor Lane/Major Mvmt	EBL	EBT	WBT	WBR	SBLn1	SBLn2
Capacity (veh/h)	1034	-	-	-	319	573
HCM Lane V/C Ratio	0.026	-	-	-	0.636	0.229
HCM Control Delay (s)	8.6	0	-	-	34.1	13.1
HCM Lane LOS	A	A	-	-	D	B
HCM 95th %tile Q(veh)	0.1	-	-	-	4.1	0.9

Intersection

Int Delay, s/veh 53.6

Movement	EBL	EBT	WBT	WBR	SBL	SBR
Lane Configurations		↕	↕		↕	↕
Traffic Vol, veh/h	33	473	356	83	351	124
Future Vol, veh/h	33	473	356	83	351	124
Conflicting Peds, #/hr	23	0	0	23	0	0
Sign Control	Free	Free	Free	Free	Stop	Stop
RT Channelized	-	None	-	None	-	None
Storage Length	-	-	-	-	0	0
Veh in Median Storage, #	-	0	0	-	0	-
Grade, %	-	0	0	-	0	-
Peak Hour Factor	100	100	100	100	100	100
Heavy Vehicles, %	2	2	6	6	0	0
Mvmt Flow	33	473	356	83	351	124

Major/Minor	Major1	Major2	Minor2
Conflicting Flow All	462	0	0
Stage 1	-	-	421
Stage 2	-	-	539
Critical Hdwy	4.12	-	6.4
Critical Hdwy Stg 1	-	-	5.4
Critical Hdwy Stg 2	-	-	5.4
Follow-up Hdwy	2.218	-	3.5
Pot Cap-1 Maneuver	1099	-	~ 287
Stage 1	-	-	667
Stage 2	-	-	589
Platoon blocked, %	-	-	-
Mov Cap-1 Maneuver	1075	-	~ 263
Mov Cap-2 Maneuver	-	-	~ 263
Stage 1	-	-	625
Stage 2	-	-	576

Approach	EB	WB	SB
HCM Control Delay, s	0.6	0	159.7
HCM LOS			F

Minor Lane/Major Mvmt	EBL	EBT	WBT	WBR	SBLn1	SBLn2
Capacity (veh/h)	1075	-	-	-	263	623
HCM Lane V/C Ratio	0.031	-	-	-	1.335	0.199
HCM Control Delay (s)	8.5	0	-	-	211.8	12.2
HCM Lane LOS	A	A	-	-	F	B
HCM 95th %tile Q(veh)	0.1	-	-	-	18.2	0.7

Notes

~: Volume exceeds capacity \$: Delay exceeds 300s +: Computation Not Defined *: All major volume in platoon

Intersection						
Int Delay, s/veh	3.3					
Movement	EBT	EBR	WBL	WBT	NBL	NBR
Lane Configurations						
Traffic Vol, veh/h	60	0	19	75	0	66
Future Vol, veh/h	60	0	19	75	0	66
Conflicting Peds, #/hr	0	0	0	0	0	0
Sign Control	Free	Free	Free	Free	Stop	Stop
RT Channelized	-	None	-	None	-	None
Storage Length	-	-	-	-	0	-
Veh in Median Storage, #	0	-	-	0	0	-
Grade, %	0	-	-	0	0	-
Peak Hour Factor	100	100	100	100	100	100
Heavy Vehicles, %	9	9	5	5	0	0
Mvmt Flow	60	0	19	75	0	66
Major/Minor	Major1	Major2	Minor1			
Conflicting Flow All	0	0	60	0	173	60
Stage 1	-	-	-	-	60	-
Stage 2	-	-	-	-	113	-
Critical Hdwy	-	-	4.15	-	6.4	6.2
Critical Hdwy Stg 1	-	-	-	-	5.4	-
Critical Hdwy Stg 2	-	-	-	-	5.4	-
Follow-up Hdwy	-	-	2.245	-	3.5	3.3
Pot Cap-1 Maneuver	-	-	1525	-	822	1011
Stage 1	-	-	-	-	968	-
Stage 2	-	-	-	-	917	-
Platoon blocked, %	-	-	-	-	-	-
Mov Cap-1 Maneuver	-	-	1525	-	811	1011
Mov Cap-2 Maneuver	-	-	-	-	811	-
Stage 1	-	-	-	-	968	-
Stage 2	-	-	-	-	905	-
Approach	EB	WB	NB			
HCM Control Delay, s	0	1.5	8.8			
HCM LOS			A			
Minor Lane/Major Mvmt	NBLn1	EBT	EBR	WBL	WBT	
Capacity (veh/h)	1011	-	-	1525	-	
HCM Lane V/C Ratio	0.065	-	-	0.012	-	
HCM Control Delay (s)	8.8	-	-	7.4	0	
HCM Lane LOS	A	-	-	A	A	
HCM 95th %tile Q(veh)	0.2	-	-	0	-	

Intersection												
Int Delay, s/veh	4.1											
Movement	EBL	EBT	EBR	WBL	WBT	WBR	NBL	NBT	NBR	SBL	SBT	SBR
Lane Configurations		↕			↕			↕			↕	
Traffic Vol, veh/h	21	9	81	18	14	5	58	141	11	5	337	37
Future Vol, veh/h	21	9	81	18	14	5	58	141	11	5	337	37
Conflicting Peds, #/hr	1	0	4	4	0	1	1	0	12	12	0	1
Sign Control	Stop	Stop	Stop	Stop	Stop	Stop	Free	Free	Free	Free	Free	Free
RT Channelized	-	-	None	-	-	None	-	-	None	-	-	None
Storage Length	-	-	-	-	-	-	-	-	-	-	-	-
Veh in Median Storage, #	-	0	-	-	0	-	-	0	-	-	0	-
Grade, %	-	0	-	-	0	-	-	0	-	-	0	-
Peak Hour Factor	86	86	86	86	86	86	86	86	86	86	86	86
Heavy Vehicles, %	13	13	13	0	0	0	10	10	10	4	4	4
Mvmt Flow	24	10	94	21	16	6	67	164	13	6	392	43

Major/Minor	Minor2		Minor1		Major1		Major2					
Conflicting Flow All	744	750	419	799	765	184	436	0	0	189	0	0
Stage 1	427	427	-	317	317	-	-	-	-	-	-	-
Stage 2	317	323	-	482	448	-	-	-	-	-	-	-
Critical Hdwy	7.23	6.63	6.33	7.1	6.5	6.2	4.2	-	-	4.14	-	-
Critical Hdwy Stg 1	6.23	5.63	-	6.1	5.5	-	-	-	-	-	-	-
Critical Hdwy Stg 2	6.23	5.63	-	6.1	5.5	-	-	-	-	-	-	-
Follow-up Hdwy	3.617	4.117	3.417	3.5	4	3.3	2.29	-	-	2.236	-	-
Pot Cap-1 Maneuver	317	327	611	306	336	864	1082	-	-	1373	-	-
Stage 1	585	567	-	698	658	-	-	-	-	-	-	-
Stage 2	671	631	-	569	576	-	-	-	-	-	-	-
Platoon blocked, %								-	-	-	-	-
Mov Cap-1 Maneuver	284	299	608	234	307	853	1081	-	-	1357	-	-
Mov Cap-2 Maneuver	284	299	-	234	307	-	-	-	-	-	-	-
Stage 1	544	563	-	642	606	-	-	-	-	-	-	-
Stage 2	603	581	-	467	572	-	-	-	-	-	-	-

Approach	EB		WB		NB		SB	
HCM Control Delay, s	15.6		19.7		2.4		0.1	
HCM LOS	C		C					

Minor Lane/Major Mvmt	NBL	NBT	NBR	EBLn1WBLn1	SBL	SBT	SBR
Capacity (veh/h)	1081	-	-	468	288	1357	-
HCM Lane V/C Ratio	0.062	-	-	0.276	0.149	0.004	-
HCM Control Delay (s)	8.6	0	-	15.6	19.7	7.7	0
HCM Lane LOS	A	A	-	C	C	A	A
HCM 95th %tile Q(veh)	0.2	-	-	1.1	0.5	0	-

Intersection

Int Delay, s/veh 11.8

Movement	EBL	EBT	WBT	WBR	SBL	SBR
Lane Configurations		↕	↕		↕	↕
Traffic Vol, veh/h	118	349	196	291	159	66
Future Vol, veh/h	118	349	196	291	159	66
Conflicting Peds, #/hr	18	0	0	18	0	0
Sign Control	Free	Free	Free	Free	Stop	Stop
RT Channelized	-	None	-	None	-	None
Storage Length	-	-	-	-	0	0
Veh in Median Storage, #	-	0	0	-	0	-
Grade, %	-	0	0	-	0	-
Peak Hour Factor	91	91	91	91	91	91
Heavy Vehicles, %	5	5	9	9	0	0
Mvmt Flow	130	384	215	320	175	73

Major/Minor	Major1	Major2	Minor2
Conflicting Flow All	553	0	0 1037 393
Stage 1	-	-	- 393 -
Stage 2	-	-	- 644 -
Critical Hdwy	4.15	-	- 6.4 6.2
Critical Hdwy Stg 1	-	-	- 5.4 -
Critical Hdwy Stg 2	-	-	- 5.4 -
Follow-up Hdwy	2.245	-	- 3.5 3.3
Pot Cap-1 Maneuver	1002	-	- 258 660
Stage 1	-	-	- 686 -
Stage 2	-	-	- 527 -
Platoon blocked, %		-	-
Mov Cap-1 Maneuver	985	-	- 207 649
Mov Cap-2 Maneuver	-	-	- 207 -
Stage 1	-	-	- 561 -
Stage 2	-	-	- 518 -

Approach	EB	WB	SB
HCM Control Delay, s	2.3	0	56.9
HCM LOS			F

Minor Lane/Major Mvmt	EBL	EBT	WBT	WBR	SBLn1	SBLn2
Capacity (veh/h)	985	-	-	-	207	649
HCM Lane V/C Ratio	0.132	-	-	-	0.844	0.112
HCM Control Delay (s)	9.2	0	-	-	75.8	11.2
HCM Lane LOS	A	A	-	-	F	B
HCM 95th %tile Q(veh)	0.5	-	-	-	6.3	0.4

Intersection

Int Delay, s/veh 18.6

Movement	EBL	EBT	WBT	WBR	SBL	SBR
Lane Configurations		↕	↕		↕	↕
Traffic Vol, veh/h	139	364	421	283	126	66
Future Vol, veh/h	139	364	421	283	126	66
Conflicting Peds, #/hr	18	0	0	18	0	0
Sign Control	Free	Free	Free	Free	Stop	Stop
RT Channelized	-	None	-	None	-	None
Storage Length	-	-	-	-	0	0
Veh in Median Storage, #	-	0	0	-	0	-
Grade, %	-	0	0	-	0	-
Peak Hour Factor	91	91	91	91	91	91
Heavy Vehicles, %	5	5	9	9	0	0
Mvmt Flow	153	400	463	311	138	73

Major/Minor	Major1	Major2	Minor2
Conflicting Flow All	792	0	0
Stage 1	-	-	637
Stage 2	-	-	706
Critical Hdwy	4.15	-	6.4
Critical Hdwy Stg 1	-	-	5.4
Critical Hdwy Stg 2	-	-	5.4
Follow-up Hdwy	2.245	-	3.5
Pot Cap-1 Maneuver	815	-	169
Stage 1	-	-	531
Stage 2	-	-	493
Platoon blocked, %		-	-
Mov Cap-1 Maneuver	801	-	~ 123
Mov Cap-2 Maneuver	-	-	~ 123
Stage 1	-	-	393
Stage 2	-	-	485

Approach	EB	WB	SB
HCM Control Delay, s	2.9	0	127.9
HCM LOS			F

Minor Lane/Major Mvmt	EBL	EBT	WBT	WBR	SBLn1	SBLn2
Capacity (veh/h)	801	-	-	-	123	473
HCM Lane V/C Ratio	0.191	-	-	-	1.126	0.153
HCM Control Delay (s)	10.6	0	-	-	187.6	14
HCM Lane LOS	B	A	-	-	F	B
HCM 95th %tile Q(veh)	0.7	-	-	-	8.2	0.5

Notes
 ~: Volume exceeds capacity \$: Delay exceeds 300s +: Computation Not Defined *: All major volume in platoon

Intersection						
Int Delay, s/veh	3.5					
Movement	EBT	EBR	WBL	WBT	NBL	NBR
Lane Configurations						
Traffic Vol, veh/h	75	0	64	45	0	31
Future Vol, veh/h	75	0	64	45	0	31
Conflicting Peds, #/hr	0	0	0	0	0	0
Sign Control	Free	Free	Free	Free	Stop	Stop
RT Channelized	-	None	-	None	-	None
Storage Length	-	-	-	-	0	-
Veh in Median Storage, #	0	-	-	0	0	-
Grade, %	0	-	-	0	0	-
Peak Hour Factor	91	91	91	91	91	91
Heavy Vehicles, %	13	13	0	0	0	0
Mvmt Flow	82	0	70	49	0	34
Major/Minor	Major1	Major2	Minor1			
Conflicting Flow All	0	0	82	0	271	82
Stage 1	-	-	-	-	82	-
Stage 2	-	-	-	-	189	-
Critical Hdwy	-	-	4.1	-	6.4	6.2
Critical Hdwy Stg 1	-	-	-	-	5.4	-
Critical Hdwy Stg 2	-	-	-	-	5.4	-
Follow-up Hdwy	-	-	2.2	-	3.5	3.3
Pot Cap-1 Maneuver	-	-	1528	-	723	983
Stage 1	-	-	-	-	946	-
Stage 2	-	-	-	-	848	-
Platoon blocked, %	-	-	-	-	-	-
Mov Cap-1 Maneuver	-	-	1528	-	689	983
Mov Cap-2 Maneuver	-	-	-	-	689	-
Stage 1	-	-	-	-	946	-
Stage 2	-	-	-	-	808	-
Approach	EB	WB	NB			
HCM Control Delay, s	0	4.4	8.8			
HCM LOS				A		
Minor Lane/Major Mvmt	NBLn1	EBT	EBR	WBL	WBT	
Capacity (veh/h)	983	-	-	1528	-	
HCM Lane V/C Ratio	0.035	-	-	0.046	-	
HCM Control Delay (s)	8.8	-	-	7.5	0	
HCM Lane LOS	A	-	-	A	A	
HCM 95th %tile Q(veh)	0.1	-	-	0.1	-	

Intersection												
Int Delay, s/veh	4											
Movement	EBL	EBT	EBR	WBL	WBT	WBR	NBL	NBT	NBR	SBL	SBT	SBR
Lane Configurations		↕			↕			↕			↕	
Traffic Vol, veh/h	37	14	73	9	7	10	77	397	23	5	149	14
Future Vol, veh/h	37	14	73	9	7	10	77	397	23	5	149	14
Conflicting Peds, #/hr	0	0	7	7	0	0	0	0	8	8	0	0
Sign Control	Stop	Stop	Stop	Stop	Stop	Stop	Free	Free	Free	Free	Free	Free
RT Channelized	-	-	None	-	-	None	-	-	None	-	-	None
Storage Length	-	-	-	-	-	-	-	-	-	-	-	-
Veh in Median Storage, #	-	0	-	-	0	-	-	0	-	-	0	-
Grade, %	-	0	-	-	0	-	-	0	-	-	0	-
Peak Hour Factor	89	89	89	89	89	89	89	89	89	89	89	89
Heavy Vehicles, %	9	9	9	5	5	5	2	2	2	6	6	6
Mvmt Flow	42	16	82	10	8	11	87	446	26	6	167	16

Major/Minor	Minor2		Minor1		Major1			Major2				
Conflicting Flow All	830	841	182	884	836	467	183	0	0	480	0	0
Stage 1	187	187	-	641	641	-	-	-	-	-	-	-
Stage 2	643	654	-	243	195	-	-	-	-	-	-	-
Critical Hdwy	7.19	6.59	6.29	7.15	6.55	6.25	4.12	-	-	4.16	-	-
Critical Hdwy Stg 1	6.19	5.59	-	6.15	5.55	-	-	-	-	-	-	-
Critical Hdwy Stg 2	6.19	5.59	-	6.15	5.55	-	-	-	-	-	-	-
Follow-up Hdwy	3.581	4.081	3.381	3.545	4.045	3.345	2.218	-	-	2.254	-	-
Pot Cap-1 Maneuver	281	294	843	263	300	590	1392	-	-	1062	-	-
Stage 1	799	732	-	458	465	-	-	-	-	-	-	-
Stage 2	450	452	-	754	734	-	-	-	-	-	-	-
Platoon blocked, %								-	-	-	-	-
Mov Cap-1 Maneuver	251	265	837	208	271	586	1392	-	-	1054	-	-
Mov Cap-2 Maneuver	251	265	-	208	271	-	-	-	-	-	-	-
Stage 1	731	728	-	416	422	-	-	-	-	-	-	-
Stage 2	396	410	-	657	730	-	-	-	-	-	-	-

Approach	EB		WB		NB		SB	
HCM Control Delay, s	17.3		18.2		1.2		0.3	
HCM LOS	C		C					

Minor Lane/Major Mvmt	NBL	NBT	NBR	EBLn1WBLn1	SBL	SBT	SBR
Capacity (veh/h)	1392	-	-	431	302	1054	-
HCM Lane V/C Ratio	0.062	-	-	0.323	0.097	0.005	-
HCM Control Delay (s)	7.8	0	-	17.3	18.2	8.4	0
HCM Lane LOS	A	A	-	C	C	A	A
HCM 95th %tile Q(veh)	0.2	-	-	1.4	0.3	0	-

Intersection

Int Delay, s/veh 32.4

Movement	EBL	EBT	WBT	WBR	SBL	SBR
Lane Configurations		↕	↕		↕	↕
Traffic Vol, veh/h	27	268	407	68	304	128
Future Vol, veh/h	27	268	407	68	304	128
Conflicting Peds, #/hr	23	0	0	23	0	0
Sign Control	Free	Free	Free	Free	Stop	Stop
RT Channelized	-	None	-	None	-	None
Storage Length	-	-	-	-	0	0
Veh in Median Storage, #	-	0	0	-	0	-
Grade, %	-	0	0	-	0	-
Peak Hour Factor	91	91	91	91	91	91
Heavy Vehicles, %	2	2	6	6	0	0
Mvmt Flow	30	295	447	75	334	141

Major/Minor	Major1	Major2	Minor2
Conflicting Flow All	545	0	0
Stage 1	-	-	-
Stage 2	-	-	-
Critical Hdwy	4.12	-	-
Critical Hdwy Stg 1	-	-	-
Critical Hdwy Stg 2	-	-	-
Follow-up Hdwy	2.218	-	-
Pot Cap-1 Maneuver	1024	-	-
Stage 1	-	-	-
Stage 2	-	-	-
Platoon blocked, %		-	-
Mov Cap-1 Maneuver	1002	-	-
Mov Cap-2 Maneuver	-	-	-
Stage 1	-	-	-
Stage 2	-	-	-

Approach	EB	WB	SB
HCM Control Delay, s	0.8	0	89.5
HCM LOS			F

Minor Lane/Major Mvmt	EBL	EBT	WBT	WBR	SBLn1	SBLn2
Capacity (veh/h)	1002	-	-	-	302	557
HCM Lane V/C Ratio	0.03	-	-	-	1.106	0.253
HCM Control Delay (s)	8.7	0	-	-	121.5	13.6
HCM Lane LOS	A	A	-	-	F	B
HCM 95th %tile Q(veh)	0.1	-	-	-	13.4	1

Notes
 ~: Volume exceeds capacity \$: Delay exceeds 300s +: Computation Not Defined *: All major volume in platoon

Intersection

Int Delay, s/veh 34

Movement	EBL	EBT	WBT	WBR	SBL	SBR
Lane Configurations		↕	↕		↕	↕
Traffic Vol, veh/h	33	544	353	58	238	122
Future Vol, veh/h	33	544	353	58	238	122
Conflicting Peds, #/hr	23	0	0	23	0	0
Sign Control	Free	Free	Free	Free	Stop	Stop
RT Channelized	-	None	-	None	-	None
Storage Length	-	-	-	-	0	0
Veh in Median Storage, #	-	0	0	-	0	-
Grade, %	-	0	0	-	0	-
Peak Hour Factor	91	91	91	91	91	91
Heavy Vehicles, %	2	2	6	6	0	0
Mvmt Flow	36	598	388	64	262	134

Major/Minor

	Major1	Major2	Minor2
Conflicting Flow All	475	0	0
Stage 1	-	-	-
Stage 2	-	-	-
Critical Hdwy	4.12	-	-
Critical Hdwy Stg 1	-	-	-
Critical Hdwy Stg 2	-	-	-
Follow-up Hdwy	2.218	-	-
Pot Cap-1 Maneuver	1087	-	-
Stage 1	-	-	-
Stage 2	-	-	-
Platoon blocked, %	-	-	-
Mov Cap-1 Maneuver	1063	-	-
Mov Cap-2 Maneuver	-	-	-
Stage 1	-	-	-
Stage 2	-	-	-

Approach

	EB	WB	SB
HCM Control Delay, s	0.5	0	126.6
HCM LOS			F

Minor Lane/Major Mvmt

	EBL	EBT	WBT	WBR	SBLn1	SBLn2
Capacity (veh/h)	1063	-	-	-	212	605
HCM Lane V/C Ratio	0.034	-	-	-	1.234	0.222
HCM Control Delay (s)	8.5	0	-	-	185	12.6
HCM Lane LOS	A	A	-	-	F	B
HCM 95th %tile Q(veh)	0.1	-	-	-	13.5	0.8

Notes

~: Volume exceeds capacity \$: Delay exceeds 300s +: Computation Not Defined *: All major volume in platoon

Intersection						
Int Delay, s/veh	3.3					
Movement	EBT	EBR	WBL	WBT	NBL	NBR
Lane Configurations						
Traffic Vol, veh/h	55	0	17	75	0	64
Future Vol, veh/h	55	0	17	75	0	64
Conflicting Peds, #/hr	0	0	0	0	0	0
Sign Control	Free	Free	Free	Free	Stop	Stop
RT Channelized	-	None	-	None	-	None
Storage Length	-	-	-	-	0	-
Veh in Median Storage, #	0	-	-	0	0	-
Grade, %	0	-	-	0	0	-
Peak Hour Factor	91	91	91	91	91	91
Heavy Vehicles, %	9	9	5	5	0	0
Mvmt Flow	60	0	19	82	0	70
Major/Minor	Major1	Major2	Minor1			
Conflicting Flow All	0	0	60	0	180	60
Stage 1	-	-	-	-	60	-
Stage 2	-	-	-	-	120	-
Critical Hdwy	-	-	4.15	-	6.4	6.2
Critical Hdwy Stg 1	-	-	-	-	5.4	-
Critical Hdwy Stg 2	-	-	-	-	5.4	-
Follow-up Hdwy	-	-	2.245	-	3.5	3.3
Pot Cap-1 Maneuver	-	-	1525	-	814	1011
Stage 1	-	-	-	-	968	-
Stage 2	-	-	-	-	910	-
Platoon blocked, %	-	-	-	-	-	-
Mov Cap-1 Maneuver	-	-	1525	-	803	1011
Mov Cap-2 Maneuver	-	-	-	-	803	-
Stage 1	-	-	-	-	968	-
Stage 2	-	-	-	-	898	-
Approach	EB	WB	NB			
HCM Control Delay, s	0	1.4	8.8			
HCM LOS				A		
Minor Lane/Major Mvmt	NBLn1	EBT	EBR	WBL	WBT	
Capacity (veh/h)	1011	-	-	1525	-	
HCM Lane V/C Ratio	0.07	-	-	0.012	-	
HCM Control Delay (s)	8.8	-	-	7.4	0	
HCM Lane LOS	A	-	-	A	A	
HCM 95th %tile Q(veh)	0.2	-	-	0	-	

Intersection												
Int Delay, s/veh	3.7											
Movement	EBL	EBT	EBR	WBL	WBT	WBR	NBL	NBT	NBR	SBL	SBT	SBR
Lane Configurations		↕			↕			↕			↕	
Traffic Vol, veh/h	21	9	88	18	14	5	65	156	12	5	368	38
Future Vol, veh/h	21	9	88	18	14	5	65	156	12	5	368	38
Conflicting Peds, #/hr	1	0	4	4	0	1	1	0	12	12	0	1
Sign Control	Stop	Stop	Stop	Stop	Stop	Stop	Free	Free	Free	Free	Free	Free
RT Channelized	-	-	None	-	-	None	-	-	None	-	-	None
Storage Length	-	-	-	-	-	-	-	-	-	-	-	-
Veh in Median Storage, #	-	0	-	-	0	-	-	0	-	-	0	-
Grade, %	-	0	-	-	0	-	-	0	-	-	0	-
Peak Hour Factor	100	100	100	100	100	100	100	100	100	100	100	100
Heavy Vehicles, %	13	13	13	0	0	0	10	10	10	4	4	4
Mvmt Flow	21	9	88	18	14	5	65	156	12	5	368	38

Major/Minor	Minor2		Minor1		Major1			Major2				
Conflicting Flow All	701	708	392	754	721	175	407	0	0	180	0	0
Stage 1	398	398	-	304	304	-	-	-	-	-	-	-
Stage 2	303	310	-	450	417	-	-	-	-	-	-	-
Critical Hdwy	7.23	6.63	6.33	7.1	6.5	6.2	4.2	-	-	4.14	-	-
Critical Hdwy Stg 1	6.23	5.63	-	6.1	5.5	-	-	-	-	-	-	-
Critical Hdwy Stg 2	6.23	5.63	-	6.1	5.5	-	-	-	-	-	-	-
Follow-up Hdwy	3.617	4.117	3.417	3.5	4	3.3	2.29	-	-	2.236	-	-
Pot Cap-1 Maneuver	339	346	633	328	356	874	1110	-	-	1384	-	-
Stage 1	606	584	-	710	667	-	-	-	-	-	-	-
Stage 2	683	640	-	592	595	-	-	-	-	-	-	-
Platoon blocked, %								-	-	-	-	-
Mov Cap-1 Maneuver	308	318	630	257	327	863	1109	-	-	1368	-	-
Mov Cap-2 Maneuver	308	318	-	257	327	-	-	-	-	-	-	-
Stage 1	566	580	-	656	617	-	-	-	-	-	-	-
Stage 2	620	592	-	497	591	-	-	-	-	-	-	-

Approach	EB		WB		NB		SB	
HCM Control Delay, s	14.4		18.1		2.4		0.1	
HCM LOS	B		C					

Minor Lane/Major Mvmt	NBL	NBT	NBR	EBLn1WBLn1	SBL	SBT	SBR
Capacity (veh/h)	1109	-	-	500	312	1368	-
HCM Lane V/C Ratio	0.059	-	-	0.236	0.119	0.004	-
HCM Control Delay (s)	8.4	0	-	14.4	18.1	7.6	0
HCM Lane LOS	A	A	-	B	C	A	A
HCM 95th %tile Q(veh)	0.2	-	-	0.9	0.4	0	-

Intersection

Int Delay, s/veh 8.6

Movement	EBL	EBT	WBT	WBR	SBL	SBR
Lane Configurations		↶	↷		↶	↷
Traffic Vol, veh/h	120	377	212	300	162	67
Future Vol, veh/h	120	377	212	300	162	67
Conflicting Peds, #/hr	18	0	0	18	0	0
Sign Control	Free	Free	Free	Free	Stop	Stop
RT Channelized	-	None	-	None	-	None
Storage Length	-	-	-	-	0	0
Veh in Median Storage, #	-	0	0	-	0	-
Grade, %	-	0	0	-	0	-
Peak Hour Factor	100	100	100	100	100	100
Heavy Vehicles, %	5	5	9	9	0	0
Mvmt Flow	120	377	212	300	162	67

Major/Minor	Major1	Major2	Minor2
Conflicting Flow All	530	0	997
Stage 1	-	-	380
Stage 2	-	-	617
Critical Hdwy	4.15	-	6.4
Critical Hdwy Stg 1	-	-	5.4
Critical Hdwy Stg 2	-	-	5.4
Follow-up Hdwy	2.245	-	3.5
Pot Cap-1 Maneuver	1022	-	273
Stage 1	-	-	696
Stage 2	-	-	542
Platoon blocked, %	-	-	-
Mov Cap-1 Maneuver	1004	-	224
Mov Cap-2 Maneuver	-	-	224
Stage 1	-	-	581
Stage 2	-	-	533

Approach	EB	WB	SB
HCM Control Delay, s	2.2	0	41.6
HCM LOS			E

Minor Lane/Major Mvmt	EBL	EBT	WBT	WBR	SBLn1	SBLn2
Capacity (veh/h)	1004	-	-	-	224	659
HCM Lane V/C Ratio	0.12	-	-	-	0.723	0.102
HCM Control Delay (s)	9.1	0	-	-	54.2	11.1
HCM Lane LOS	A	A	-	-	F	B
HCM 95th %tile Q(veh)	0.4	-	-	-	4.8	0.3

Intersection

Int Delay, s/veh 12.1

Movement	EBL	EBT	WBT	WBR	SBL	SBR
Lane Configurations		↕	↕		↕	↕
Traffic Vol, veh/h	141	393	450	287	128	67
Future Vol, veh/h	141	393	450	287	128	67
Conflicting Peds, #/hr	18	0	0	18	0	0
Sign Control	Free	Free	Free	Free	Stop	Stop
RT Channelized	-	None	-	None	-	None
Storage Length	-	-	-	-	0	0
Veh in Median Storage, #	-	0	0	-	0	-
Grade, %	-	0	0	-	0	-
Peak Hour Factor	100	100	100	100	100	100
Heavy Vehicles, %	5	5	9	9	0	0
Mvmt Flow	141	393	450	287	128	67

Major/Minor	Major1	Major2	Minor2
Conflicting Flow All	755	0	0
Stage 1	-	-	-
Stage 2	-	-	-
Critical Hdwy	4.15	-	-
Critical Hdwy Stg 1	-	-	-
Critical Hdwy Stg 2	-	-	-
Follow-up Hdwy	2.245	-	-
Pot Cap-1 Maneuver	842	-	-
Stage 1	-	-	-
Stage 2	-	-	-
Platoon blocked, %	-	-	-
Mov Cap-1 Maneuver	828	-	-
Mov Cap-2 Maneuver	-	-	-
Stage 1	-	-	-
Stage 2	-	-	-

Approach	EB	WB	SB
HCM Control Delay, s	2.7	0	83.7
HCM LOS			F

Minor Lane/Major Mvmt	EBL	EBT	WBT	WBR	SBLn1	SBLn2
Capacity (veh/h)	828	-	-	-	138	488
HCM Lane V/C Ratio	0.17	-	-	-	0.928	0.137
HCM Control Delay (s)	10.2	0	-	-	120.4	13.5
HCM Lane LOS	B	A	-	-	F	B
HCM 95th %tile Q(veh)	0.6	-	-	-	6.3	0.5

Intersection						
Int Delay, s/veh	3.5					
Movement	EBT	EBR	WBL	WBT	NBL	NBR
Lane Configurations						
Traffic Vol, veh/h	80	0	67	50	0	33
Future Vol, veh/h	80	0	67	50	0	33
Conflicting Peds, #/hr	0	0	0	0	0	0
Sign Control	Free	Free	Free	Free	Stop	Stop
RT Channelized	-	None	-	None	-	None
Storage Length	-	-	-	-	0	-
Veh in Median Storage, #	0	-	-	0	0	-
Grade, %	0	-	-	0	0	-
Peak Hour Factor	100	100	100	100	100	100
Heavy Vehicles, %	13	13	0	0	0	0
Mvmt Flow	80	0	67	50	0	33
Major/Minor	Major1	Major2	Minor1			
Conflicting Flow All	0	0	80	0	264	80
Stage 1	-	-	-	-	80	-
Stage 2	-	-	-	-	184	-
Critical Hdwy	-	-	4.1	-	6.4	6.2
Critical Hdwy Stg 1	-	-	-	-	5.4	-
Critical Hdwy Stg 2	-	-	-	-	5.4	-
Follow-up Hdwy	-	-	2.2	-	3.5	3.3
Pot Cap-1 Maneuver	-	-	1531	-	729	986
Stage 1	-	-	-	-	948	-
Stage 2	-	-	-	-	852	-
Platoon blocked, %	-	-	-	-	-	-
Mov Cap-1 Maneuver	-	-	1531	-	696	986
Mov Cap-2 Maneuver	-	-	-	-	696	-
Stage 1	-	-	-	-	948	-
Stage 2	-	-	-	-	814	-
Approach	EB	WB	NB			
HCM Control Delay, s	0	4.3	8.8			
HCM LOS				A		
Minor Lane/Major Mvmt	NBLn1	EBT	EBR	WBL	WBT	
Capacity (veh/h)	986	-	-	1531	-	
HCM Lane V/C Ratio	0.033	-	-	0.044	-	
HCM Control Delay (s)	8.8	-	-	7.5	0	
HCM Lane LOS	A	-	-	A	A	
HCM 95th %tile Q(veh)	0.1	-	-	0.1	-	

Intersection												
Int Delay, s/veh	3.6											
Movement	EBL	EBT	EBR	WBL	WBT	WBR	NBL	NBT	NBR	SBL	SBT	SBR
Lane Configurations		↕			↕			↕			↕	
Traffic Vol, veh/h	38	14	79	9	7	10	78	433	28	5	159	14
Future Vol, veh/h	38	14	79	9	7	10	78	433	28	5	159	14
Conflicting Peds, #/hr	0	0	7	7	0	0	0	0	8	8	0	0
Sign Control	Stop	Stop	Stop	Stop	Stop	Stop	Free	Free	Free	Free	Free	Free
RT Channelized	-	-	None	-	-	None	-	-	None	-	-	None
Storage Length	-	-	-	-	-	-	-	-	-	-	-	-
Veh in Median Storage, #	-	0	-	-	0	-	-	0	-	-	0	-
Grade, %	-	0	-	-	0	-	-	0	-	-	0	-
Peak Hour Factor	100	100	100	100	100	100	100	100	100	100	100	100
Heavy Vehicles, %	9	9	9	5	5	5	2	2	2	6	6	6
Mvmt Flow	38	14	79	9	7	10	78	433	28	5	159	14

Major/Minor	Minor2		Minor1		Major1			Major2				
Conflicting Flow All	788	801	173	841	794	455	173	0	0	469	0	0
Stage 1	176	176	-	611	611	-	-	-	-	-	-	-
Stage 2	612	625	-	230	183	-	-	-	-	-	-	-
Critical Hdwy	7.19	6.59	6.29	7.15	6.55	6.25	4.12	-	-	4.16	-	-
Critical Hdwy Stg 1	6.19	5.59	-	6.15	5.55	-	-	-	-	-	-	-
Critical Hdwy Stg 2	6.19	5.59	-	6.15	5.55	-	-	-	-	-	-	-
Follow-up Hdwy	3.581	4.081	3.381	3.545	4.045	3.345	2.218	-	-	2.254	-	-
Pot Cap-1 Maneuver	301	310	853	281	317	599	1404	-	-	1072	-	-
Stage 1	810	740	-	476	480	-	-	-	-	-	-	-
Stage 2	469	467	-	766	743	-	-	-	-	-	-	-
Platoon blocked, %								-	-	-	-	-
Mov Cap-1 Maneuver	273	283	847	227	289	594	1404	-	-	1064	-	-
Mov Cap-2 Maneuver	273	283	-	227	289	-	-	-	-	-	-	-
Stage 1	749	736	-	437	441	-	-	-	-	-	-	-
Stage 2	420	429	-	673	739	-	-	-	-	-	-	-

Approach	EB		WB		NB			SB		
HCM Control Delay, s	15.8		17.2		1.1			0.2		
HCM LOS	C		C							

Minor Lane/Major Mvmt	NBL	NBT	NBR	EBLn1WBLn1	SBL	SBT	SBR
Capacity (veh/h)	1404	-	-	465	322	1064	-
HCM Lane V/C Ratio	0.056	-	-	0.282	0.081	0.005	-
HCM Control Delay (s)	7.7	0	-	15.8	17.2	8.4	0
HCM Lane LOS	A	A	-	C	C	A	A
HCM 95th %tile Q(veh)	0.2	-	-	1.1	0.3	0	-

Intersection

Int Delay, s/veh 23.4

Movement	EBL	EBT	WBT	WBR	SBL	SBR
Lane Configurations		↕	↕		↕	↕
Traffic Vol, veh/h	28	288	439	70	313	131
Future Vol, veh/h	28	288	439	70	313	131
Conflicting Peds, #/hr	23	0	0	23	0	0
Sign Control	Free	Free	Free	Free	Stop	Stop
RT Channelized	-	None	-	None	-	None
Storage Length	-	-	-	-	0	0
Veh in Median Storage, #	-	0	0	-	0	-
Grade, %	-	0	0	-	0	-
Peak Hour Factor	100	100	100	100	100	100
Heavy Vehicles, %	2	2	6	6	0	0
Mvmt Flow	28	288	439	70	313	131

Major/Minor	Major1	Major2	Minor2
Conflicting Flow All	532	0	841
Stage 1	-	-	497
Stage 2	-	-	344
Critical Hdwy	4.12	-	6.4
Critical Hdwy Stg 1	-	-	5.4
Critical Hdwy Stg 2	-	-	5.4
Follow-up Hdwy	2.218	-	3.5
Pot Cap-1 Maneuver	1036	-	338
Stage 1	-	-	615
Stage 2	-	-	722
Platoon blocked, %	-	-	-
Mov Cap-1 Maneuver	1013	-	313
Mov Cap-2 Maneuver	-	-	313
Stage 1	-	-	582
Stage 2	-	-	706

Approach	EB	WB	SB
HCM Control Delay, s	0.8	0	66.2
HCM LOS			F

Minor Lane/Major Mvmt	EBL	EBT	WBT	WBR	SBLn1	SBLn2
Capacity (veh/h)	1013	-	-	-	313	564
HCM Lane V/C Ratio	0.028	-	-	-	1	0.232
HCM Control Delay (s)	8.7	0	-	-	88.4	13.3
HCM Lane LOS	A	A	-	-	F	B
HCM 95th %tile Q(veh)	0.1	-	-	-	10.8	0.9

Intersection

Int Delay, s/veh 23.6

Movement	EBL	EBT	WBT	WBR	SBL	SBR
Lane Configurations		↕	↕		↕	↕
Traffic Vol, veh/h	33	583	380	58	241	124
Future Vol, veh/h	33	583	380	58	241	124
Conflicting Peds, #/hr	23	0	0	23	0	0
Sign Control	Free	Free	Free	Free	Stop	Stop
RT Channelized	-	None	-	None	-	None
Storage Length	-	-	-	-	0	0
Veh in Median Storage, #	-	0	0	-	0	-
Grade, %	-	0	0	-	0	-
Peak Hour Factor	100	100	100	100	100	100
Heavy Vehicles, %	2	2	6	6	0	0
Mvmt Flow	33	583	380	58	241	124

Major/Minor	Major1	Major2	Minor2
Conflicting Flow All	461	0	0 1081 432
Stage 1	-	-	- 432 -
Stage 2	-	-	- 649 -
Critical Hdwy	4.12	-	- 6.4 6.2
Critical Hdwy Stg 1	-	-	- 5.4 -
Critical Hdwy Stg 2	-	-	- 5.4 -
Follow-up Hdwy	2.218	-	- 3.5 3.3
Pot Cap-1 Maneuver	1100	-	- 243 628
Stage 1	-	-	- 659 -
Stage 2	-	-	- 524 -
Platoon blocked, %		-	-
Mov Cap-1 Maneuver	1076	-	- ~ 222 614
Mov Cap-2 Maneuver	-	-	- ~ 222 -
Stage 1	-	-	- 616 -
Stage 2	-	-	- 512 -

Approach	EB	WB	SB
HCM Control Delay, s	0.5	0	91
HCM LOS			F

Minor Lane/Major Mvmt	EBL	EBT	WBT	WBR	SBLn1	SBLn2
Capacity (veh/h)	1076	-	-	-	222	614
HCM Lane V/C Ratio	0.031	-	-	-	1.086	0.202
HCM Control Delay (s)	8.5	0	-	-	131.5	12.3
HCM Lane LOS	A	A	-	-	F	B
HCM 95th %tile Q(veh)	0.1	-	-	-	10.8	0.8

Notes

~: Volume exceeds capacity \$: Delay exceeds 300s +: Computation Not Defined *: All major volume in platoon

Intersection						
Int Delay, s/veh	3.3					
Movement	EBT	EBR	WBL	WBT	NBL	NBR
Lane Configurations						
Traffic Vol, veh/h	60	0	19	75	0	66
Future Vol, veh/h	60	0	19	75	0	66
Conflicting Peds, #/hr	0	0	0	0	0	0
Sign Control	Free	Free	Free	Free	Stop	Stop
RT Channelized	-	None	-	None	-	None
Storage Length	-	-	-	-	0	-
Veh in Median Storage, #	0	-	-	0	0	-
Grade, %	0	-	-	0	0	-
Peak Hour Factor	100	100	100	100	100	100
Heavy Vehicles, %	9	9	5	5	0	0
Mvmt Flow	60	0	19	75	0	66
Major/Minor	Major1	Major2	Minor1			
Conflicting Flow All	0	0	60	0	173	60
Stage 1	-	-	-	-	60	-
Stage 2	-	-	-	-	113	-
Critical Hdwy	-	-	4.15	-	6.4	6.2
Critical Hdwy Stg 1	-	-	-	-	5.4	-
Critical Hdwy Stg 2	-	-	-	-	5.4	-
Follow-up Hdwy	-	-	2.245	-	3.5	3.3
Pot Cap-1 Maneuver	-	-	1525	-	822	1011
Stage 1	-	-	-	-	968	-
Stage 2	-	-	-	-	917	-
Platoon blocked, %	-	-	-	-	-	-
Mov Cap-1 Maneuver	-	-	1525	-	811	1011
Mov Cap-2 Maneuver	-	-	-	-	811	-
Stage 1	-	-	-	-	968	-
Stage 2	-	-	-	-	905	-
Approach	EB	WB	NB			
HCM Control Delay, s	0	1.5	8.8			
HCM LOS			A			
Minor Lane/Major Mvmt	NBLn1	EBT	EBR	WBL	WBT	
Capacity (veh/h)	1011	-	-	1525	-	
HCM Lane V/C Ratio	0.065	-	-	0.012	-	
HCM Control Delay (s)	8.8	-	-	7.4	0	
HCM Lane LOS	A	-	-	A	A	
HCM 95th %tile Q(veh)	0.2	-	-	0	-	

Intersection						
Int Delay, s/veh	4.4					
Movement	EBL	EBT	WBT	WBR	SBL	SBR
Lane Configurations		↔	↔		↔	↔
Traffic Vol, veh/h	105	415	262	117	76	29
Future Vol, veh/h	105	415	262	117	76	29
Conflicting Peds, #/hr	18	0	0	18	0	0
Sign Control	Free	Free	Free	Free	Stop	Stop
RT Channelized	-	None	-	None	-	None
Storage Length	-	-	-	-	0	0
Veh in Median Storage, #	-	0	0	-	0	-
Grade, %	-	0	0	-	0	-
Peak Hour Factor	85	85	85	85	85	85
Heavy Vehicles, %	5	5	9	9	0	0
Mvmt Flow	124	488	308	138	89	34

Major/Minor	Major1	Major2	Minor2		
Conflicting Flow All	464	0	-	0	1130 395
Stage 1	-	-	-	-	395 -
Stage 2	-	-	-	-	735 -
Critical Hdwy	4.15	-	-	-	6.4 6.2
Critical Hdwy Stg 1	-	-	-	-	5.4 -
Critical Hdwy Stg 2	-	-	-	-	5.4 -
Follow-up Hdwy	2.245	-	-	-	3.5 3.3
Pot Cap-1 Maneuver	1082	-	-	-	227 659
Stage 1	-	-	-	-	685 -
Stage 2	-	-	-	-	478 -
Platoon blocked, %		-	-	-	
Mov Cap-1 Maneuver	1063	-	-	-	185 647
Mov Cap-2 Maneuver	-	-	-	-	185 -
Stage 1	-	-	-	-	566 -
Stage 2	-	-	-	-	470 -

Approach	EB	WB	SB
HCM Control Delay, s/v	1.78	0	33.11
HCM LOS			D

Minor Lane/Major Mvmt	EBL	EBT	WBT	WBR	SBLn1	SBLn2
Capacity (veh/h)	363	-	-	-	185	647
HCM Lane V/C Ratio	0.116	-	-	-	0.485	0.053
HCM Control Delay (s/veh)	8.8	0	-	-	41.6	10.9
HCM Lane LOS	A	A	-	-	E	B
HCM 95th %tile Q(veh)	0.4	-	-	-	2.4	0.2

Intersection						
Int Delay, s/veh	19.5					
Movement	EBL	EBT	WBT	WBR	SBL	SBR
Lane Configurations		↔	↔		↔	↔
Traffic Vol, veh/h	77	422	477	310	121	65
Future Vol, veh/h	77	422	477	310	121	65
Conflicting Peds, #/hr	18	0	0	18	0	0
Sign Control	Free	Free	Free	Free	Stop	Stop
RT Channelized	-	None	-	None	-	None
Storage Length	-	-	-	-	0	0
Veh in Median Storage, #	-	0	0	-	0	-
Grade, %	-	0	0	-	0	-
Peak Hour Factor	85	85	85	85	85	85
Heavy Vehicles, %	5	5	9	9	0	0
Mvmt Flow	91	496	561	365	142	76

Major/Minor	Major1	Major2	Minor2		
Conflicting Flow All	944	0	-	0	1439 762
Stage 1	-	-	-	-	762 -
Stage 2	-	-	-	-	678 -
Critical Hdwy	4.15	-	-	-	6.4 6.2
Critical Hdwy Stg 1	-	-	-	-	5.4 -
Critical Hdwy Stg 2	-	-	-	-	5.4 -
Follow-up Hdwy	2.245	-	-	-	3.5 3.3
Pot Cap-1 Maneuver	715	-	-	-	148 408
Stage 1	-	-	-	-	465 -
Stage 2	-	-	-	-	508 -
Platoon blocked, %		-	-	-	
Mov Cap-1 Maneuver	702	-	-	-	~ 117 401
Mov Cap-2 Maneuver	-	-	-	-	~ 117 -
Stage 1	-	-	-	-	375 -
Stage 2	-	-	-	-	499 -

Approach	EB	WB	SB
HCM Control Delay, s/v	1.68	0	149.5
HCM LOS			F

Minor Lane/Major Mvmt	EBL	EBT	WBT	WBR	SBLn1	SBLn2
Capacity (veh/h)	278	-	-	-	117	401
HCM Lane V/C Ratio	0.129	-	-	-	1.212	0.191
HCM Control Delay (s/veh)	10.9	0	-	-	221.2	16.1
HCM Lane LOS	B	A	-	-	F	C
HCM 95th %tile Q(veh)	0.4	-	-	-	9	0.7

Notes
 ~: Volume exceeds capacity \$: Delay exceeds 300s +: Computation Not Defined *: All major volume in platoon

Intersection

Int Delay, s/veh 9.8

Movement	EBL	EBT	WBT	WBR	SBL	SBR
Lane Configurations	↘	↑	↗		↘	↗
Traffic Vol, veh/h	107	394	341	205	115	53
Future Vol, veh/h	107	394	341	205	115	53
Conflicting Peds, #/hr	12	0	0	12	1	0
Sign Control	Free	Free	Free	Free	Stop	Stop
RT Channelized	-	None	-	None	-	None
Storage Length	100	-	-	-	0	0
Veh in Median Storage, #	-	0	0	-	0	-
Grade, %	-	0	0	-	0	-
Peak Hour Factor	85	85	85	85	85	85
Heavy Vehicles, %	5	5	9	9	0	0
Mvmt Flow	126	464	401	241	135	62

Major/Minor

	Major1	Major2	Minor2
Conflicting Flow All	654	0	0
Stage 1	-	-	-
Stage 2	-	-	-
Critical Hdwy	4.15	-	-
Critical Hdwy Stg 1	-	-	-
Critical Hdwy Stg 2	-	-	-
Follow-up Hdwy	2.245	-	-
Pot Cap-1 Maneuver	919	-	-
Stage 1	-	-	-
Stage 2	-	-	-
Platoon blocked, %		-	-
Mov Cap-1 Maneuver	908	-	-
Mov Cap-2 Maneuver	-	-	-
Stage 1	-	-	-
Stage 2	-	-	-

Approach

	EB	WB	SB
HCM Control Delay, s/v	2.05	0	64.59
HCM LOS			F

Minor Lane/Major Mvmt

	EBL	EBT	WBT	WBR	SBLn1	SBLn2
Capacity (veh/h)	908	-	-	-	162	544
HCM Lane V/C Ratio	0.139	-	-	-	0.835	0.115
HCM Control Delay (s/veh)	9.6	-	-	-	88.6	12.5
HCM Lane LOS	A	-	-	-	F	B
HCM 95th %tile Q(veh)	0.5	-	-	-	5.6	0.4

Intersection						
Int Delay, s/veh	4.5					
Movement	EBL	EBT	WBT	WBR	SBL	SBR
Lane Configurations		↔	↔		↔	↔
Traffic Vol, veh/h	105	415	241	139	76	51
Future Vol, veh/h	105	415	241	139	76	51
Conflicting Peds, #/hr	18	0	0	18	0	0
Sign Control	Free	Free	Free	Free	Stop	Stop
RT Channelized	-	None	-	None	-	None
Storage Length	-	-	-	-	0	0
Veh in Median Storage, #	-	0	0	-	0	-
Grade, %	-	0	0	-	0	-
Peak Hour Factor	85	85	85	85	85	85
Heavy Vehicles, %	5	5	9	9	0	0
Mvmt Flow	124	488	284	164	89	60

Major/Minor	Major1	Major2	Minor2		
Conflicting Flow All	465	0	-	0	1119 383
Stage 1	-	-	-	-	383 -
Stage 2	-	-	-	-	735 -
Critical Hdwy	4.15	-	-	-	6.4 6.2
Critical Hdwy Stg 1	-	-	-	-	5.4 -
Critical Hdwy Stg 2	-	-	-	-	5.4 -
Follow-up Hdwy	2.245	-	-	-	3.5 3.3
Pot Cap-1 Maneuver	1081	-	-	-	231 669
Stage 1	-	-	-	-	693 -
Stage 2	-	-	-	-	478 -
Platoon blocked, %		-	-	-	
Mov Cap-1 Maneuver	1062	-	-	-	188 657
Mov Cap-2 Maneuver	-	-	-	-	188 -
Stage 1	-	-	-	-	573 -
Stage 2	-	-	-	-	470 -

Approach	EB	WB	SB
HCM Control Delay, s/v	1.78	0	28.7
HCM LOS			D

Minor Lane/Major Mvmt	EBL	EBT	WBT	WBR	SBLn1	SBLn2
Capacity (veh/h)	363	-	-	-	188	657
HCM Lane V/C Ratio	0.116	-	-	-	0.477	0.091
HCM Control Delay (s/veh)	8.8	0	-	-	40.6	11
HCM Lane LOS	A	A	-	-	E	B
HCM 95th %tile Q(veh)	0.4	-	-	-	2.3	0.3

Intersection						
Int Delay, s/veh	17.7					
Movement	EBL	EBT	WBT	WBR	SBL	SBR
Lane Configurations		↕	↕		↕	↕
Traffic Vol, veh/h	77	433	543	243	110	43
Future Vol, veh/h	77	433	543	243	110	43
Conflicting Peds, #/hr	18	0	0	18	0	0
Sign Control	Free	Free	Free	Free	Stop	Stop
RT Channelized	-	None	-	None	-	None
Storage Length	-	-	-	-	0	0
Veh in Median Storage, #	-	0	0	-	0	-
Grade, %	-	0	0	-	0	-
Peak Hour Factor	85	85	85	85	85	85
Heavy Vehicles, %	5	5	9	9	0	0
Mvmt Flow	91	509	639	286	129	51

Major/Minor	Major1	Major2	Minor2		
Conflicting Flow All	943	0	-	0	1490 800
Stage 1	-	-	-	-	800 -
Stage 2	-	-	-	-	691 -
Critical Hdwy	4.15	-	-	-	6.4 6.2
Critical Hdwy Stg 1	-	-	-	-	5.4 -
Critical Hdwy Stg 2	-	-	-	-	5.4 -
Follow-up Hdwy	2.245	-	-	-	3.5 3.3
Pot Cap-1 Maneuver	715	-	-	-	138 388
Stage 1	-	-	-	-	446 -
Stage 2	-	-	-	-	501 -
Platoon blocked, %		-	-	-	
Mov Cap-1 Maneuver	703	-	-	-	~ 109 382
Mov Cap-2 Maneuver	-	-	-	-	~ 109 -
Stage 1	-	-	-	-	359 -
Stage 2	-	-	-	-	493 -

Approach	EB	WB	SB
HCM Control Delay, s/v	1.64	0	161.96
HCM LOS			F

Minor Lane/Major Mvmt	EBL	EBT	WBT	WBR	SBLn1	SBLn2
Capacity (veh/h)	272	-	-	-	109	382
HCM Lane V/C Ratio	0.129	-	-	-	1.186	0.133
HCM Control Delay (s/veh)	10.9	0	-	-	219.1	15.9
HCM Lane LOS	B	A	-	-	F	C
HCM 95th %tile Q(veh)	0.4	-	-	-	8.4	0.5

Notes
 ~: Volume exceeds capacity \$: Delay exceeds 300s +: Computation Not Defined *: All major volume in platoon

Intersection

Int Delay, s/veh 13.2

Movement	EBL	EBT	WBT	WBR	SBL	SBR
Lane Configurations	↘	↑	↗		↘	↗
Traffic Vol, veh/h	107	395	342	250	126	53
Future Vol, veh/h	107	395	342	250	126	53
Conflicting Peds, #/hr	12	0	0	12	1	0
Sign Control	Free	Free	Free	Free	Stop	Stop
RT Channelized	-	None	-	None	-	None
Storage Length	100	-	-	-	0	0
Veh in Median Storage, #	-	0	0	-	0	-
Grade, %	-	0	0	-	0	-
Peak Hour Factor	85	85	85	85	85	85
Heavy Vehicles, %	5	5	9	9	0	0
Mvmt Flow	126	465	402	294	148	62

Major/Minor

	Major1	Major2	Minor2
Conflicting Flow All	708	0	0
Stage 1	-	-	-
Stage 2	-	-	-
Critical Hdwy	4.15	-	-
Critical Hdwy Stg 1	-	-	-
Critical Hdwy Stg 2	-	-	-
Follow-up Hdwy	2.245	-	-
Pot Cap-1 Maneuver	877	-	-
Stage 1	-	-	-
Stage 2	-	-	-
Platoon blocked, %		-	-
Mov Cap-1 Maneuver	867	-	-
Mov Cap-2 Maneuver	-	-	-
Stage 1	-	-	-
Stage 2	-	-	-

Approach

	EB	WB	SB
HCM Control Delay, s/v	2.1	0	88.11
HCM LOS			F

Minor Lane/Major Mvmt

	EBL	EBT	WBT	WBR	SBLn1	SBLn2
Capacity (veh/h)	867	-	-	-	155	525
HCM Lane V/C Ratio	0.145	-	-	-	0.959	0.119
HCM Control Delay (s/veh)	9.9	-	-	-	119.8	12.8
HCM Lane LOS	A	-	-	-	F	B
HCM 95th %tile Q(veh)	0.5	-	-	-	7.1	0.4

Intersection						
Int Delay, s/veh	7					
Movement	EBL	EBT	WBT	WBR	SBL	SBR
Lane Configurations		↕	↕		↕	↕
Traffic Vol, veh/h	26	296	538	26	146	55
Future Vol, veh/h	26	296	538	26	146	55
Conflicting Peds, #/hr	23	0	0	23	0	0
Sign Control	Free	Free	Free	Free	Stop	Stop
RT Channelized	-	None	-	None	-	None
Storage Length	-	-	-	-	0	0
Veh in Median Storage, #	-	0	0	-	0	-
Grade, %	-	0	0	-	0	-
Peak Hour Factor	90	90	90	90	90	90
Heavy Vehicles, %	2	2	6	6	0	0
Mvmt Flow	29	329	598	29	162	61

Major/Minor	Major1	Major2	Minor2		
Conflicting Flow All	650	0	-	0	1022 635
Stage 1	-	-	-	-	635 -
Stage 2	-	-	-	-	387 -
Critical Hdwy	4.12	-	-	-	6.4 6.2
Critical Hdwy Stg 1	-	-	-	-	5.4 -
Critical Hdwy Stg 2	-	-	-	-	5.4 -
Follow-up Hdwy	2.218	-	-	-	3.5 3.3
Pot Cap-1 Maneuver	936	-	-	-	264 482
Stage 1	-	-	-	-	532 -
Stage 2	-	-	-	-	691 -
Platoon blocked, %		-	-	-	
Mov Cap-1 Maneuver	916	-	-	-	243 471
Mov Cap-2 Maneuver	-	-	-	-	243 -
Stage 1	-	-	-	-	500 -
Stage 2	-	-	-	-	676 -

Approach	EB	WB	SB
HCM Control Delay, s/v	0.73	0	36.74
HCM LOS			E

Minor Lane/Major Mvmt	EBL	EBT	WBT	WBR	SBLn1	SBLn2
Capacity (veh/h)	145	-	-	-	243	471
HCM Lane V/C Ratio	0.032	-	-	-	0.669	0.13
HCM Control Delay (s/veh)	9.1	0	-	-	45.4	13.8
HCM Lane LOS	A	A	-	-	E	B
HCM 95th %tile Q(veh)	0.1	-	-	-	4.3	0.4

Intersection						
Int Delay, s/veh	43.4					
Movement	EBL	EBT	WBT	WBR	SBL	SBR
Lane Configurations		↔	↔		↔	↔
Traffic Vol, veh/h	17	641	380	71	233	126
Future Vol, veh/h	17	641	380	71	233	126
Conflicting Peds, #/hr	23	0	0	23	0	0
Sign Control	Free	Free	Free	Free	Stop	Stop
RT Channelized	-	None	-	None	-	None
Storage Length	-	-	-	-	0	0
Veh in Median Storage, #	-	0	0	-	0	-
Grade, %	-	0	0	-	0	-
Peak Hour Factor	90	90	90	90	90	90
Heavy Vehicles, %	2	2	6	6	0	0
Mvmt Flow	19	712	422	79	259	140

Major/Minor	Major1	Major2	Minor2		
Conflicting Flow All	524	0	-	0	1235 485
Stage 1	-	-	-	-	485 -
Stage 2	-	-	-	-	750 -
Critical Hdwy	4.12	-	-	-	6.4 6.2
Critical Hdwy Stg 1	-	-	-	-	5.4 -
Critical Hdwy Stg 2	-	-	-	-	5.4 -
Follow-up Hdwy	2.218	-	-	-	3.5 3.3
Pot Cap-1 Maneuver	1043	-	-	-	~ 197 586
Stage 1	-	-	-	-	623 -
Stage 2	-	-	-	-	470 -
Platoon blocked, %		-	-	-	
Mov Cap-1 Maneuver	1020	-	-	-	~ 182 574
Mov Cap-2 Maneuver	-	-	-	-	~ 182 -
Stage 1	-	-	-	-	591 -
Stage 2	-	-	-	-	460 -

Approach	EB	WB	SB
HCM Control Delay, s/v	0.22	0	177.07
HCM LOS			F

Minor Lane/Major Mvmt	EBL	EBT	WBT	WBR	SBLn1	SBLn2
Capacity (veh/h)	47	-	-	-	182	574
HCM Lane V/C Ratio	0.019	-	-	-	1.419	0.244
HCM Control Delay (s/veh)	8.6	0	-	-	265.6	13.3
HCM Lane LOS	A	A	-	-	F	B
HCM 95th %tile Q(veh)	0.1	-	-	-	15.7	1

Notes
 ~: Volume exceeds capacity \$: Delay exceeds 300s +: Computation Not Defined *: All major volume in platoon

Intersection

Int Delay, s/veh 23.9

Movement	EBL	EBT	WBT	WBR	SBL	SBR
Lane Configurations	↘	↑	↗		↘	↗
Traffic Vol, veh/h	25	437	466	45	220	102
Future Vol, veh/h	25	437	466	45	220	102
Conflicting Peds, #/hr	14	0	0	14	4	1
Sign Control	Free	Free	Free	Free	Stop	Stop
RT Channelized	-	None	-	None	-	None
Storage Length	100	-	-	-	0	0
Veh in Median Storage, #	-	0	0	-	0	-
Grade, %	-	0	0	-	0	-
Peak Hour Factor	90	90	90	90	90	90
Heavy Vehicles, %	2	2	6	6	0	0
Mvmt Flow	28	486	518	50	244	113

Major/Minor

	Major1	Major2	Minor2
Conflicting Flow All	582	0	0 1102 558
Stage 1	-	-	- 557 -
Stage 2	-	-	- 545 -
Critical Hdwy	4.12	-	- 6.4 6.2
Critical Hdwy Stg 1	-	-	- 5.4 -
Critical Hdwy Stg 2	-	-	- 5.4 -
Follow-up Hdwy	2.218	-	- 3.5 3.3
Pot Cap-1 Maneuver	992	-	- ~ 236 533
Stage 1	-	-	- 578 -
Stage 2	-	-	- 585 -
Platoon blocked, %		-	-
Mov Cap-1 Maneuver	979	-	- ~ 224 526
Mov Cap-2 Maneuver	-	-	- ~ 224 -
Stage 1	-	-	- 554 -
Stage 2	-	-	- 577 -

Approach

	EB	WB	SB
HCM Control Delay, s/v	0.48	0	95.62
HCM LOS			F

Minor Lane/Major Mvmt

	EBL	EBT	WBT	WBR	SBLn1	SBLn2
Capacity (veh/h)	979	-	-	-	224	526
HCM Lane V/C Ratio	0.028	-	-	-	1.093	0.216
HCM Control Delay (s/veh)	8.8	-	-	-	133.6	13.7
HCM Lane LOS	A	-	-	-	F	B
HCM 95th %tile Q(veh)	0.1	-	-	-	11	0.8

Notes

~: Volume exceeds capacity \$: Delay exceeds 300s +: Computation Not Defined *: All major volume in platoon

Intersection						
Int Delay, s/veh	6.8					
Movement	EBL	EBT	WBT	WBR	SBL	SBR
Lane Configurations		↕	↕		↕	↕
Traffic Vol, veh/h	26	296	494	33	146	99
Future Vol, veh/h	26	296	494	33	146	99
Conflicting Peds, #/hr	23	0	0	23	0	0
Sign Control	Free	Free	Free	Free	Stop	Stop
RT Channelized	-	None	-	None	-	None
Storage Length	-	-	-	-	0	0
Veh in Median Storage, #	-	0	0	-	0	-
Grade, %	-	0	0	-	0	-
Peak Hour Factor	90	90	90	90	90	90
Heavy Vehicles, %	2	2	6	6	0	0
Mvmt Flow	29	329	549	37	162	110

Major/Minor	Major1	Major2	Minor2		
Conflicting Flow All	609	0	-	0	977 590
Stage 1	-	-	-	-	590 -
Stage 2	-	-	-	-	387 -
Critical Hdwy	4.12	-	-	-	6.4 6.2
Critical Hdwy Stg 1	-	-	-	-	5.4 -
Critical Hdwy Stg 2	-	-	-	-	5.4 -
Follow-up Hdwy	2.218	-	-	-	3.5 3.3
Pot Cap-1 Maneuver	970	-	-	-	281 511
Stage 1	-	-	-	-	558 -
Stage 2	-	-	-	-	691 -
Platoon blocked, %		-	-	-	
Mov Cap-1 Maneuver	949	-	-	-	258 500
Mov Cap-2 Maneuver	-	-	-	-	258 -
Stage 1	-	-	-	-	525 -
Stage 2	-	-	-	-	676 -

Approach	EB	WB	SB
HCM Control Delay, s/v	0.72	0	29.48
HCM LOS			D

Minor Lane/Major Mvmt	EBL	EBT	WBT	WBR	SBLn1	SBLn2
Capacity (veh/h)	145	-	-	-	258	500
HCM Lane V/C Ratio	0.03	-	-	-	0.628	0.22
HCM Control Delay (s/veh)	8.9	0	-	-	39.8	14.2
HCM Lane LOS	A	A	-	-	E	B
HCM 95th %tile Q(veh)	0.1	-	-	-	3.8	0.8

Intersection						
Int Delay, s/veh	36.7					
Movement	EBL	EBT	WBT	WBR	SBL	SBR
Lane Configurations		↔	↔		↔	↔
Traffic Vol, veh/h	17	663	399	53	211	82
Future Vol, veh/h	17	663	399	53	211	82
Conflicting Peds, #/hr	23	0	0	23	0	0
Sign Control	Free	Free	Free	Free	Stop	Stop
RT Channelized	-	None	-	None	-	None
Storage Length	-	-	-	-	0	0
Veh in Median Storage, #	-	0	0	-	0	-
Grade, %	-	0	0	-	0	-
Peak Hour Factor	90	90	90	90	90	90
Heavy Vehicles, %	2	2	6	6	0	0
Mvmt Flow	19	737	443	59	234	91

Major/Minor	Major1	Major2	Minor2		
Conflicting Flow All	525	0	-	0	1270 496
Stage 1	-	-	-	-	496 -
Stage 2	-	-	-	-	774 -
Critical Hdwy	4.12	-	-	-	6.4 6.2
Critical Hdwy Stg 1	-	-	-	-	5.4 -
Critical Hdwy Stg 2	-	-	-	-	5.4 -
Follow-up Hdwy	2.218	-	-	-	3.5 3.3
Pot Cap-1 Maneuver	1042	-	-	-	~ 187 578
Stage 1	-	-	-	-	616 -
Stage 2	-	-	-	-	458 -
Platoon blocked, %		-	-	-	
Mov Cap-1 Maneuver	1019	-	-	-	~ 174 565
Mov Cap-2 Maneuver	-	-	-	-	~ 174 -
Stage 1	-	-	-	-	584 -
Stage 2	-	-	-	-	448 -

Approach	EB	WB	SB
HCM Control Delay, s/v	0.22	0	177.84
HCM LOS			F

Minor Lane/Major Mvmt	EBL	EBT	WBT	WBR	SBLn1	SBLn2
Capacity (veh/h)	45	-	-	-	174	565
HCM Lane V/C Ratio	0.019	-	-	-	1.351	0.161
HCM Control Delay (s/veh)	8.6	0	-	-	242.1	12.6
HCM Lane LOS	A	A	-	-	F	B
HCM 95th %tile Q(veh)	0.1	-	-	-	13.9	0.6

Notes
 ~: Volume exceeds capacity \$: Delay exceeds 300s +: Computation Not Defined *: All major volume in platoon

Intersection

Int Delay, s/veh	28.6					
Movement	EBL	EBT	WBT	WBR	SBL	SBR
Lane Configurations	↘	↑	↗		↘	↗
Traffic Vol, veh/h	24	437	429	57	242	102
Future Vol, veh/h	24	437	429	57	242	102
Conflicting Peds, #/hr	14	0	0	14	4	1
Sign Control	Free	Free	Free	Free	Stop	Stop
RT Channelized	-	None	-	None	-	None
Storage Length	100	-	-	-	0	0
Veh in Median Storage, #	-	0	0	-	0	-
Grade, %	-	0	0	-	0	-
Peak Hour Factor	90	90	90	90	90	90
Heavy Vehicles, %	2	2	6	6	0	0
Mvmt Flow	27	486	477	63	269	113

Major/Minor

	Major1	Major2	Minor2		
Conflicting Flow All	554	0	-	0	1065
Stage 1	-	-	-	-	522
Stage 2	-	-	-	-	543
Critical Hdwy	4.12	-	-	-	6.4
Critical Hdwy Stg 1	-	-	-	-	5.4
Critical Hdwy Stg 2	-	-	-	-	5.4
Follow-up Hdwy	2.218	-	-	-	3.5
Pot Cap-1 Maneuver	1016	-	-	-	~ 249
Stage 1	-	-	-	-	599
Stage 2	-	-	-	-	586
Platoon blocked, %		-	-	-	
Mov Cap-1 Maneuver	1003	-	-	-	~ 236
Mov Cap-2 Maneuver	-	-	-	-	~ 236
Stage 1	-	-	-	-	575
Stage 2	-	-	-	-	579

Approach

	EB	WB	SB
HCM Control Delay, s/v	0.45	0	106.84
HCM LOS			F

Minor Lane/Major Mvmt

	EBL	EBT	WBT	WBR	SBLn1	SBLn2
Capacity (veh/h)	1003	-	-	-	236	550
HCM Lane V/C Ratio	0.027	-	-	-	1.142	0.206
HCM Control Delay (s/veh)	8.7	-	-	-	146.3	13.2
HCM Lane LOS	A	-	-	-	F	B
HCM 95th %tile Q(veh)	0.1	-	-	-	12.3	0.8

Notes

~: Volume exceeds capacity \$: Delay exceeds 300s +: Computation Not Defined *: All major volume in platoon

Appendix I Staff Zipcode Maps

Appendix J Meridian Avenue N/N 115th Street
Intersection Vehicle Maneuvers

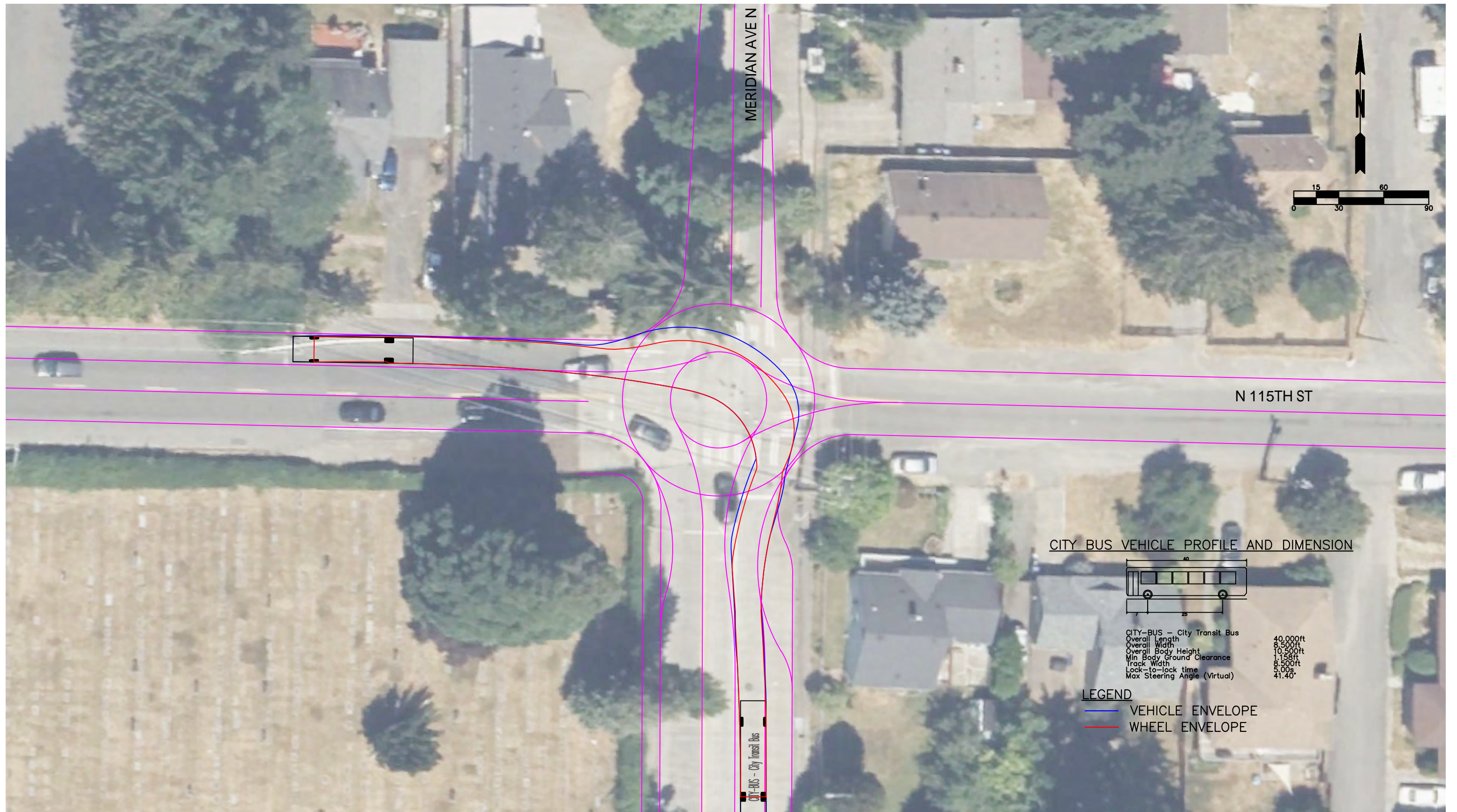

Mini Roundabout Concept - City Bus Turning Maneuvers

1.22083.00 - UWMC

December 14, 2023



FIGURE

1

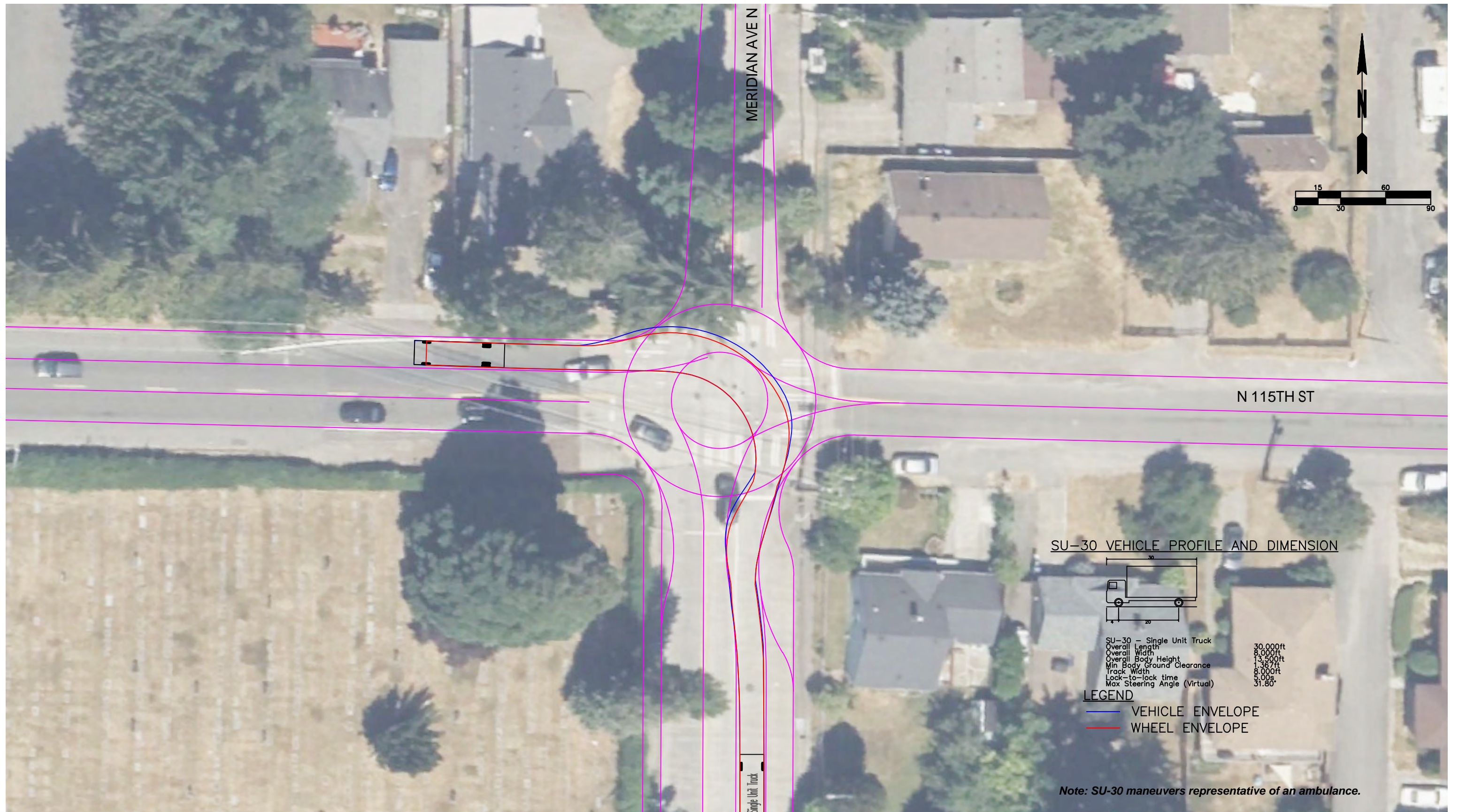

Mini Roundabout Concept - SU-30 Turning Maneuvers

1.22083.00 - UWMC

December 14, 2023

FIGURE

2